



# AUTOMATIC VALVE

## Mr.Wash Pro

### USER MANUAL



## CONTENTS

1. IMPORTANT SAFETY INSTRUCTIONS.....	1
2. TECHNICAL SPECIFICATIONS.....	3
3. OVERALL DIMENSIONS.....	5
4. SETTINGS AND OPERATION.....	6
5. APPLICATIONS.....	13
6. WIFI Operation.....	20
7. WARNINGS AND FAILURES.....	27
8. WARRANTY AND EXCLUSIONS.....	32
9. DISPOSAL.....	33

**THANK YOU FOR PURCHASING OUR AUTOMATIC MULTIPOINT VALVES.**

**THIS MANUAL CONTAINS IMPORTANT INFORMATION TO HELP YOU IN THE OPERATION AND MAINTENANCE OF THIS PRODUCT. READ THIS MANUAL CAREFULLY BEFORE INSTALLATION AND OPERATION AND KEEP IT FOR FUTURE REFERENCE.**

## 1. IMPORTANT SAFETY INSTRUCTIONS

This manual is intended for users involved in assembly, installation, commissioning and maintenance.

The contents of the manual must be clearly legible and must be kept in a place where it can be consulted at any time.

Make sure that the person responsible for operating the device has read and understood this manual.

him.

### 1.1 Use

This product is an automatic multi-way valve for swimming pool sand filtration, its purpose is to achieve automatic backwash function. In addition, it supports the connection of external devices such as

are: pool pumps, central control, electromagnetic valves, power failure protection

etc.. For use it is necessary to observe the following information:

This product may only be operated within the scope of use specified in this manual, any other use

or use beyond this is not the intended use and must be approved first

manufacturer/supplier.

### 1.2 Users

Ensure that only qualified personnel operate this product.

- Qualified mechanical engineer.
- Qualified electrical engineers or electricians.
- Relevant persons who are not qualified but have undergone the necessary training.
- Persons who have read this manual and understand the necessary work procedures.

### 1.3 Safety regulations

Users are required to comply with the following regulations:

- This manual.
- Safety warning signs on the product.
- Relevant applicable national regulations for accident prevention.
- Internal operational safety regulations for professionals.

### 1.4 Device safety

- Touching moving parts, such as rotating gears, can cause serious injury.
- Dismantling or modifying the device structure without the manufacturer's permission is prohibited.
- Use only original manufacturer parts. Use of parts from other manufacturers or unauthorized products may void the warranty or cause other problems.
- Make sure that all markings on the device are legible.
- Do not perform maintenance while the unit is in operation. Reconnect immediately after repairs are completed. all protective devices with new activation.

### 1.5 Electrical safety To avoid

the increased risk of electric shock due to damp environments, the user must observe the following regulations:

- Correctly install the electrical protective earth conductor to prevent electric shock by current.
- Check the electrical system regularly to ensure it is in proper working order.
- Always disconnect the system from the power source before performing maintenance on the electrical system. During maintenance, add warning signs to ensure that the system is de-energized.
- Electrical work should only be carried out by a specialist.
- Do not immerse the product in water and ensure that no liquids or objects enter the product's electrical controls.

### 1.6 Installation and maintenance

- All accessories supplied with the product must be tightened to the specified position using a wrench or pliers. cutting pliers to prevent water leakage.
- When installing this product, tighten it as much as possible to prevent leakage from the pipe due to vibration.
- When installing, minimize pressure on the connection between this product and the pipe to prevent leakage.
- In the event of a malfunction, immediately turn off the pump and then close the valve before you can disconnect the power supply and repair malfunctioning equipment.

## 2. TECHNICAL SPECIFICATIONS

### 2.1 Specifications

Model Number	iWash Pro-S
Filter type	Side mounting
Filter size	450 - 900mm
Flushing flow	24 m <sup>3</sup> /h at a pressure loss of 0.1 MPa
IP protection	IP65

### 2.2 Application conditions

Working condition	Working pressure	≤ 0.25 MPa
	Water temperature	5℃ - 50℃
	Salt concentration	≤ 0.5% (5kg/m <sup>3</sup> )
Working environment	Ambient temperature	5℃ - 50℃
	Humidity	≤ 95% (25℃)
	Power supply	AC 100-240V/50-60Hz
	Power adapter output	DC 24V, 1.5A

### 2.1. Pressure loss curve

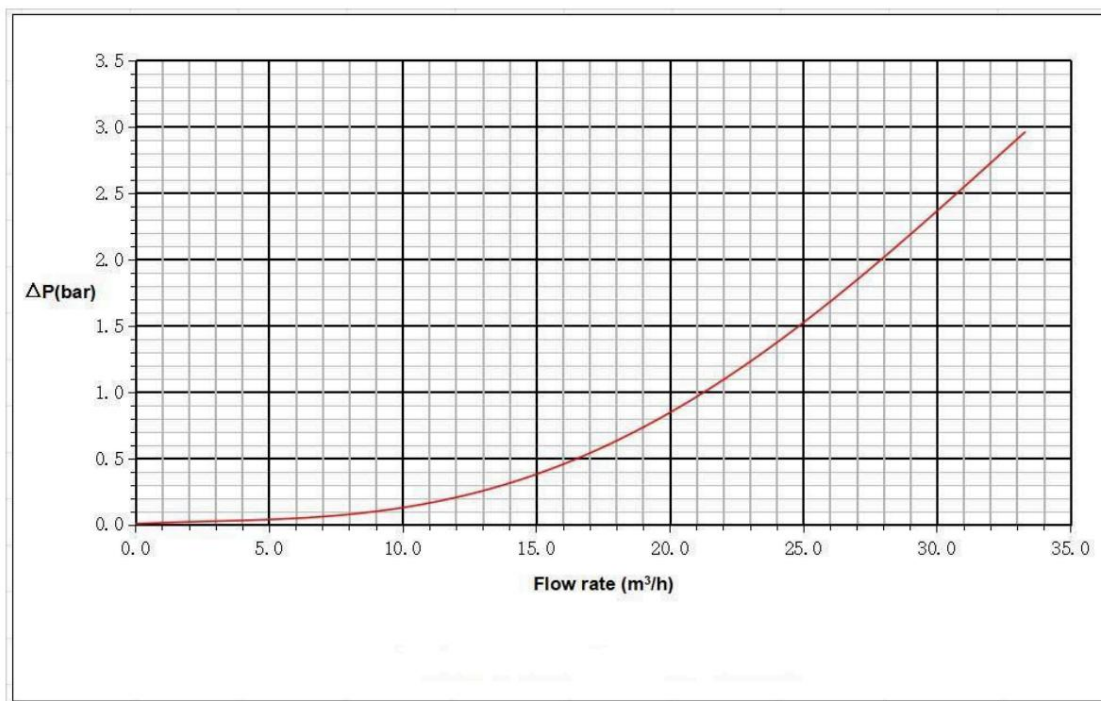
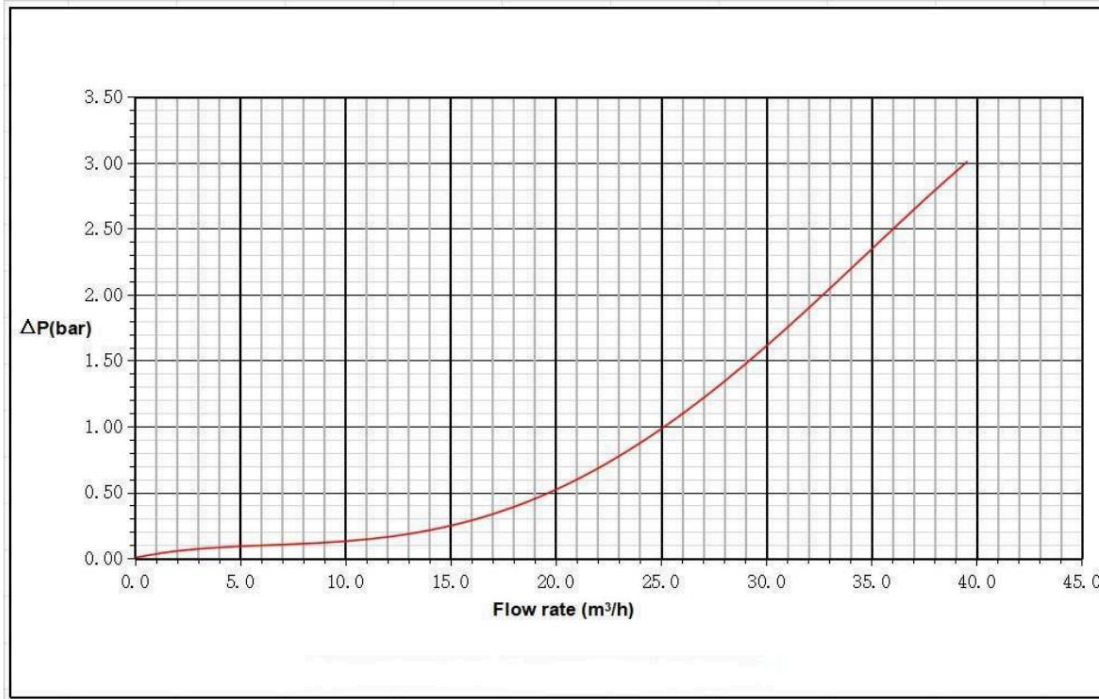

Figure 1 - Pressure loss curve - Filtration mode



**Figure 2 - Pressure loss curve - backwash mode**

## 2.2. Built-in battery

If the automatic multi-way valve is in backwash mode, waste mode, or rotation, and a power failure occurs, the built-in battery of the automatic multi-way valve and turns the valve into filtration mode to prevent the pool from emptying.

The built-in battery will power the valve for 10 minutes. During the power-up period, the valve will automatically the multi-way valve will start automatically and users will not be able to control it.

**Note:** When installing the automatic multi-way valve for the first time, please connect it to the power supply for at least 4 hours to charge the built-in battery.

The specifications of the built-in battery are as follows:

Type	Lithium battery
Capacity	750mAh (11.4Wh)
Discharge temperature	-10°C~60°C
Charging temperature	0°C~45°C
Battery life	10 minutes
Charging time	4 hours

### 3. OVERALL DIMENSION

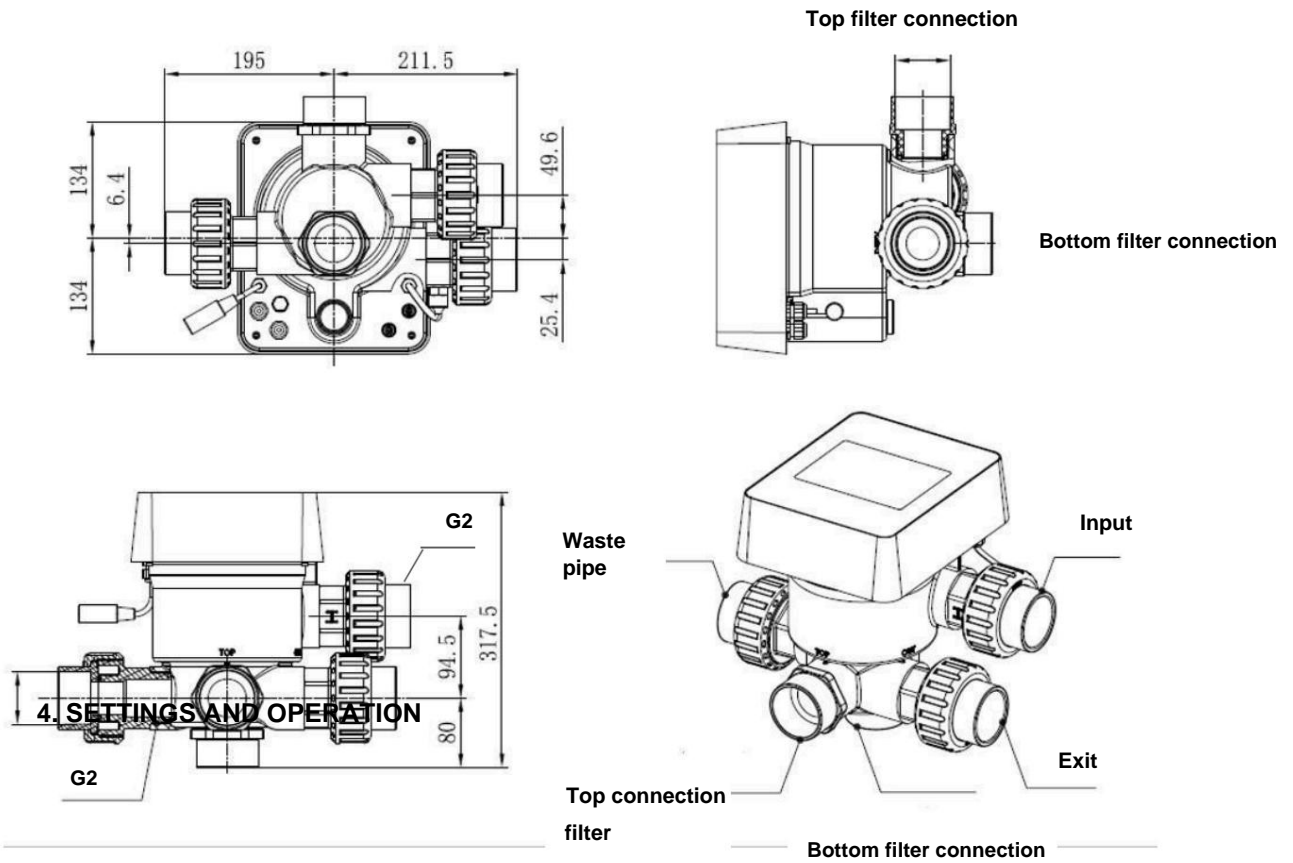

### 4. SETTINGS AND OPERATION

Figure 3 - Multi-way valve dimensions

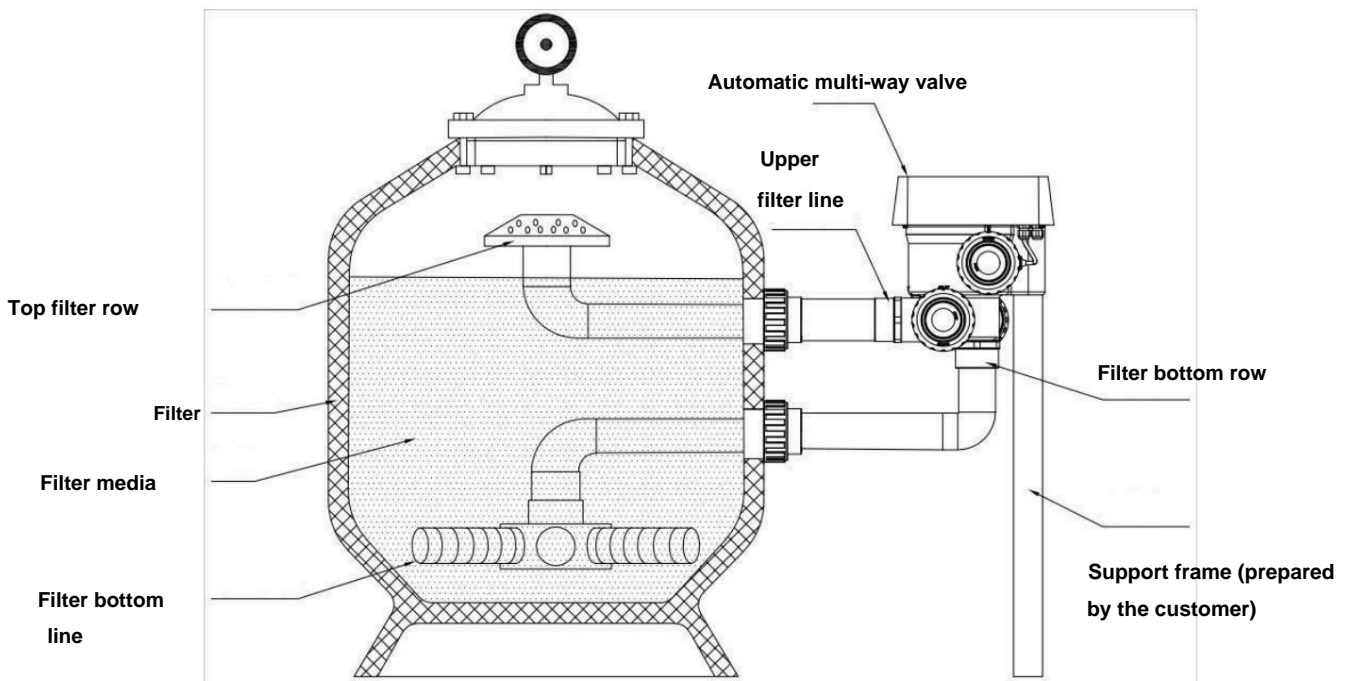

Figure 4 - Installation diagram









Model	Fitting size		Backwash flow
	Input / output / waste conduit	Upper/lower pipe filter	(m <sup>3</sup> /h at 0.1 MPa)
iWash Pro-S	Inner diameter 48.3/50mm (Including reduction)	Inner diameter 48.3/50mm	24
	Inner diameter 60.3/63mm	Inner diameter 60.3/63mm	

Figure 5 - Union size





#### 4. SETTINGS AND OPERATION



## 4.1 Parameter display

Description	Displays	Note
	Filtration mode	Home position
	Backwash mode	Including rinsing
	Waste regime	/
	Recirculation mode	/
	Closed mode	/
	Current time	00:00 by default
	Days left to activate automatic return flushing	This value is only displayed when the user in the settings parameters activates automatic backwashing with timers
	Countdown procedure backwash	This time includes the return procedure of rinsing and rinsing.

## 4.2 Button Guide

Name button		Function	Description
	Regime	Backwash with one by touch	Press to activate the reverse procedure. flushing + rinsing
		Mode selection	Hold the button for 3 seconds to enter mode selection
		Cancel	Hold to deselect
	Up	Select mode	Press to select different modes
		Change the value	Press to change the value in the setting parameter
	Down	Select mode	Press to select different modes
		Change the value	Press to change the value in the setting parameter
	Confirm	Confirm mode	Press to confirm the mode
		Confirm settings parameter	Press to confirm the parameter setting.
		Unlock the screen	Hold the button for 3 seconds to screen unlock

### 4.3 Switching on and off

#### 4.3.1 Power on



Connect the power cord to the power source. After powering on, the display will light up. Then the valve will turn to the default the "Filter" position and the corresponding indicator will light up.

#### 4.3.2 Power off

Disconnect the power cable from the electricity, the screen will turn off.

### 4.4 Locking and unlocking the screen

#### 4.4.1 Locking

The screen will automatically lock if you do not perform any operation for more than 1 minute. Brightness screen will decrease and  will flash. Press briefly  wake up the screen and you check the status.

#### 4.4.2 Unlock

When the screen locks,  to unlock it, hold it for 3 seconds.

### 4.5 Mode

The automatic multi-way valve has five modes: filter, backwash (including rinsing), recirculation, waste and closed.

#### Mode selection

I. Hold  for 3 seconds, the current mode indicator will flash and the other mode indicators will light up.

II. Pressing  or  select a mode.

III. Press  to confirm, the current mode indicator and the selected mode indicator will light up will flash and the automatic multi-way valve will turn to the corresponding position.

If the confirmation button is not pressed  within 10 seconds the automatic multi-way valve returns to the previous regime without any change.

#### Cancel the selected mode

Hold down the button when switching mod  for 3 seconds to cancel and auto multi-way the valve will return to the previous mode without change.

#### 4 .5.1 Filtration mode:

In filtration mode, the corresponding indicator will light up. The display will alternately show the current time and the days remaining until automatic backwash is activated.

When switching from other modes to filtration mode, the other modes indicator will light up and the filtration mode indicator will flash. When the valve switches to the filtration position, the other modes indicator will turn off.

Note: when the automatic backwash by timer is off (see 4.6.1, parameter No.2), it won't show the days remaining to activate the automatic backwash.

#### 4 .5.2 Backwash mode (including rinsing)





When switching from other modes to backwash mode, the other modes indicator will light up and the backwash mode indicator will flash. The automatic multi-way valve will perform the backwash and rinsing process accordingly. Users can set the rinsing time ratio in backwash mode in the parameter setting (see 4.6.1, parameter No. 5).



Below is the backwash and rinse procedure:

- I. The backwash duration will be displayed on the screen. After turning the valve to the backwash position, the backwash mode indicator will light up, the other indicator will go out and the backwash countdown will start.
- II. After the backwash is finished, the countdown will stop and the backwash mode indicator will flash. The valve will turn to the rinse position and then the backwash mode indicator will light up.
- III. The countdown continues and stops when the rinse is complete. The previous mode indicator will flash and the valve will turn to the previous mode.

##### a. Switch to backwash mode

In any mode (Filter, Recirculation, Waste, Closed)

I. Hold the button  for 3 seconds to enter mode selection, press the button  or  to select backwash mode, then press the button  to continue with the setup backwash duration.

II. Press the button  or  to set the duration of the backwash mode (default value is 3 minutes, adjustable 1–25 minutes).

III. Press the button  to save the settings and activate backwash mode.

**Note: 1) The**

**duration of the backwash mode can ONLY be set as described above.**

**The set duration will be used for one-touch backwash and automatic backwash using timer and pressure.**

**2) Backwash mode includes backwash and rinsing process. The default setting of the rinsing duration ratio in backwash mode is 30%.**

**For example: If the backwash mode duration setting is 3 minutes (180 seconds) and the rinse duration ratio is 30%, then the backwash duration will be 126 seconds (70%) and the rinse duration will be 54 seconds (30%).**

**3) Users can hold the buttons and  and  for 3 seconds to enter parameter settings set the rinsing time ratio as needed (see 4.6.1, parameter No. 5).**

#### **b. One-touch backwash**

**In any mode (Filter, Recirculation, Waste, Closed), users can short press the button to**



**immediately activate automatic backflushing.**

#### **c. Automatic backwash with timer**

**The timer activation can be set in the parameter settings (see 4.6.1, parameter No. 2 and No. 3). Before using this function, make sure that the current time setting is correct.**

**E.g.: If users want to activate automatic backflush every 10 days at 10:30.**

- I. Go to parameter No. 2 and change the parameter to 10;**
- II. Go to parameter No. 3 and change the setting to 10:30;**

#### **d. Automatic pressure backwash**

**Users can set the pressure value to activate automatic backwash in the parameter setting (see 4.6.1, parameter No. 4). If the pressure sensor detects that the current pressure is higher than the set value for more than 1 minute, the valve will perform backwash.**

#### **4.5.3 Waste Mode When**

**switching from other modes to waste mode, the second mode indicator will light up and the waste mode indicator will flash. When the valve reaches the Waste position, the Waste mode indicator will light up and the second mode indicator will go out. The current time will be displayed on the screen.**

#### **4.5.4 Recirculation mode**

**When switching from other modes to Recirculation mode, the second mode indicator will light up and the Recirculation mode indicator will flash. When the valve reaches the recirculation position, the recirculation mode indicator will light up and the second mode indicator will go out. The current time will be displayed on the screen.**

#### **4. 5.5 Closed mode When**

**switching from another mode to closed mode, the second mode indicator will light up and the closed mode indicator will flash. When the valve reaches the closed position, the closed mode indicator will light up and The second mode indicator will go out. The current time will be displayed on the screen.**

## 4.6 Parameter setting and querying

### 4.6.1 Parameter settings

In any mode (when the valve is not rotating), hold



for 3 seconds to enter

parameter settings.

In the parameter setting interface, the parameter values are listed on the left side and the is the parameter address.

I. After entering the parameter address, the parameter value (all digits) will flash, press



you switch to different parameter addresses.

II. Press



, if a specific parameter value needs to be edited, and an editable digit in the value parameter starts flashing.

III. Press



to switch between different digits, press up or down to adjust

values and press



for completion.

Address parameter	Description	Default	Setting range	Unit
0	Current time	/	00:00 – 23:59	Hour and minute
1	Reverse speed flushing inverter pool pump	100	60-100	%
2	Automatic flushing with timers (every X days)	0	0-30	day
3	Timer start time automatic backwash	12:30	00:00 – 23:59	Hour and minute
4	Automatic return pressure flushing	0.200 200 29.0 2.00 /	0 / 0.05 0 -0.25 0 0 / 50-250 0 / 7.3-36.3 0 / 0.50-2.50 0: disabled	MPa KPa <small>Canine</small> Bar /
5	Duration share rinse in reverse mode flushing	30	10-50	%

6	Type of pool pumps	0	0: Inverter pool pump 1: Single-speed pump 2: Pool pump with digital input	/
7	Pressure unit	0	0: MPa 1: KPa 2: Dogs 3: Bar	/
8	valve position switching	30	0: Pump stops 30 : Pump speed at 30%	%
9	85-Modbus control	0	0 : Control panel 1: 485-Modbus Control	/
AND	85- Modbus address	10	1-247	/

**Note:**

- (1) Parameter address 1 and 8 will only be valid if the pool pump type is inverter type with adjustable power.
- (2) Automatic pressure backflushing will be disabled if parameter address 4 is set to " 0 ", in this case the current pressure can still be read.
- (3) If the pool pump type setting in parameter address 6 has been changed, it must be the automatic multi-way valve is re-activated to activate the setting.

**4.6.2 Parameter query**

In any mode (valve not rotating), the user can hold



check the current parameter.

In the parameter query interface, the parameter values are on the left side and the address is on the right side parameter.

Parameter address	Parameter	Unit
0	Current pressure value	MPa / Kpa / Psi / Bar
1	Current temperature	°C
3	Driver board version	-
4	Display board version	-

## 5. APPLICATION

### 5.1 Ports and connections

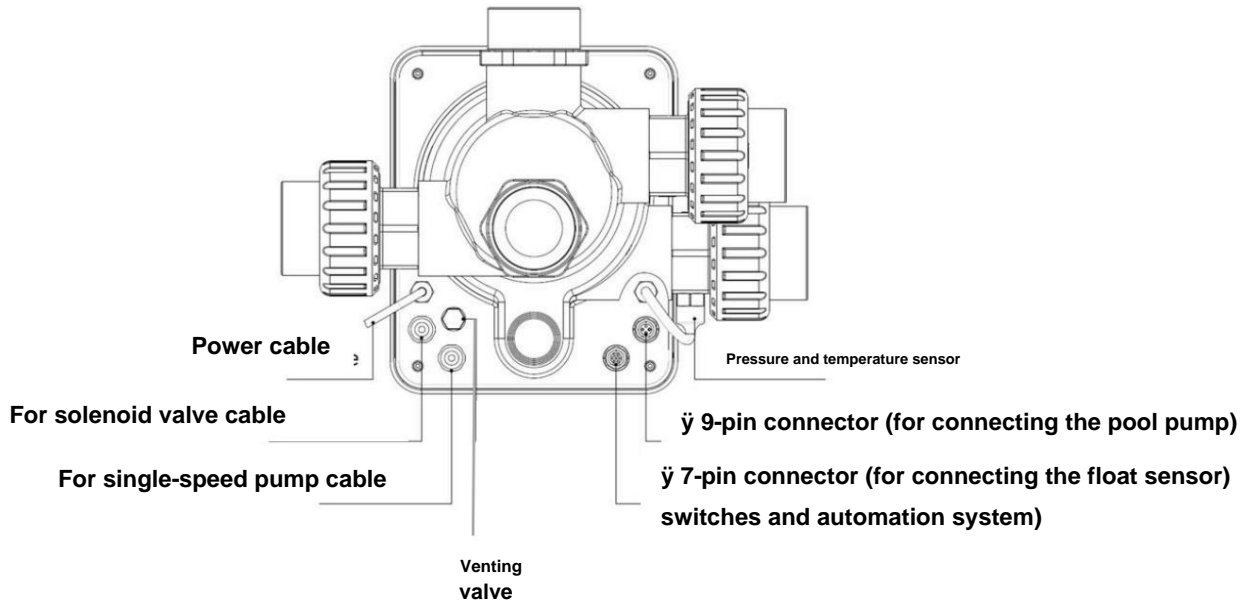
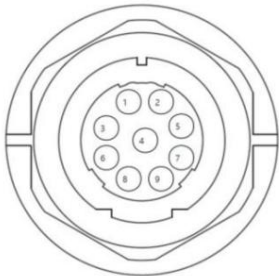
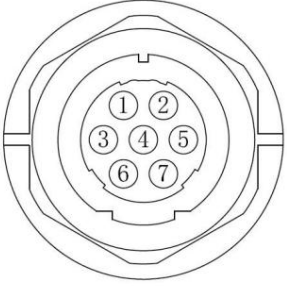

Figure 6 – Connection port

### 5.2 Communication port

9 pin connector (for connecting the inverter pool pump)					
	Name	Color	Description	Type settings pool pump (see 4.6.1, parameter no. 6)	
	PIN 1	RED		Digital output 4 (V1)	2: Pool pump with digital input
	PIN 2	BLACK		Digital output 3 (V2)	
	PIN 3	WHITE		Digital output 2 (V3)	
	PIN 4	GRAY		Digital output 1 (Stop)	
	PIN 5	YELLOW		Digital Earth	0: Inverter pool pump
	PIN 6	GREEN		RS485 A	
	PIN 7	BROWN		RS485 B	Not available
	PIN 8	BLUE		/	
	PIN 9	ORANGE		GND	

**Note:** The nominal speed of the pool pump with digital input (speed V1/V2/V3) can be changed in the iGarden application (see 3.4 in chapter 6).

<b>7 pin connector</b>					
(for connecting the float sensor of the filling sensor and the pool automatics)					
	Name	Color	Description	Note	
	PIN 1	R	RED	/	/
	PIN 2	B	BLACK	GND (float switch)	For float sensor switches (customer supplied)
	PIN 3	W	WHITE	Float switch	
	PIN 4	G	GREY	/	/
	PIN 5	Y	YELLOW	R S485 Earth	
	PIN 6	G	GREEN	R S485 A	For automation system swimming pool (provides customer)
	PIN 7	B	BROWN	R S485 B	

### 5.2.1 Solenoid valve terminal block

#### a. Valve 1: Solenoid valve on the drain line

The automatic multi-way valve provides an interface for connecting an external solenoid valve (customer supplied). By connecting to a solenoid valve on the drain pipe, it is possible to prevent emptying the pool in the event of a power outage during backwashing or draining.

The solenoid valve terminal block is non-contact. The rated input voltage is 24-220V, the maximum

the input current is 2 A and controls an external normally closed solenoid valve.

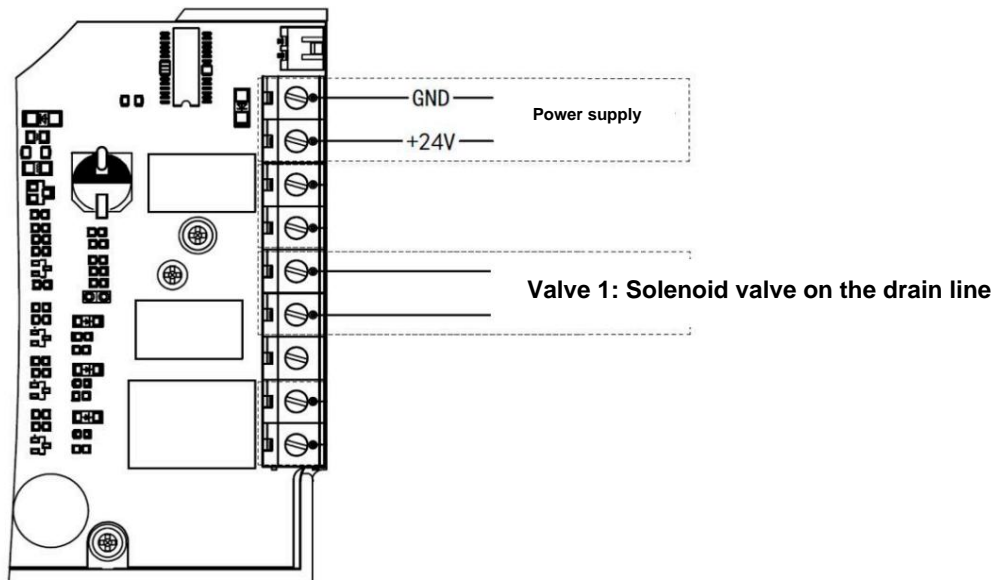

Figure 7 - Solenoid valve terminal blocFigure 7 - Terminal block

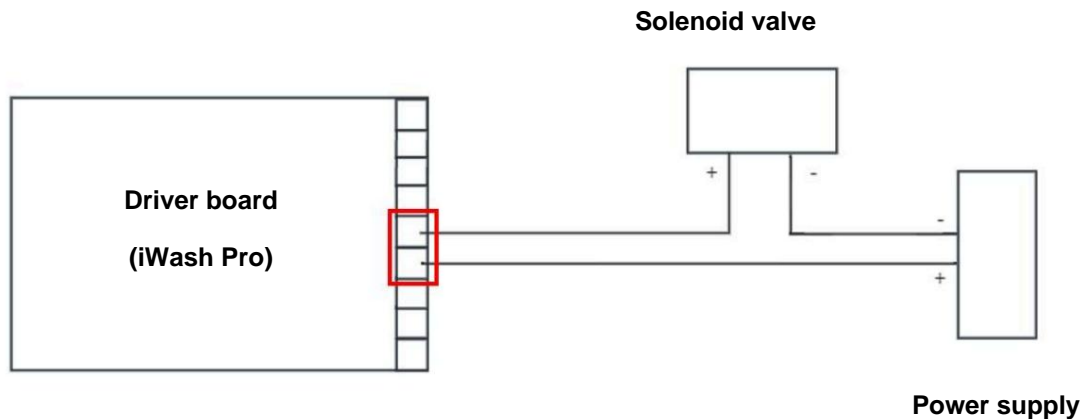

Figure 8 - Solenoid valve wiring diagram (valve 1)

**b. Water supply solenoid valve**

The solenoid valve terminal block is a potential-free contact. The rated input voltage is 24-220V, the maximum input current is 2A, which controls an external normally closed solenoid valve.

When the external float switch sensor (supplied by the customer) triggers the water refill signal, the automatic multi-way valve controls the solenoid valve on the water supply line, which opens and the pool is automatically refilled.

**Note:** The water replenishment signal triggered by the float switch must last for 2 minutes, after which the automatic multi-way valve can control the solenoid valve on the water supply pipe.

When the float switch sensor triggers the stop water refill signal, the solenoid valve on the water supply line closes and the pool stops refilling water.

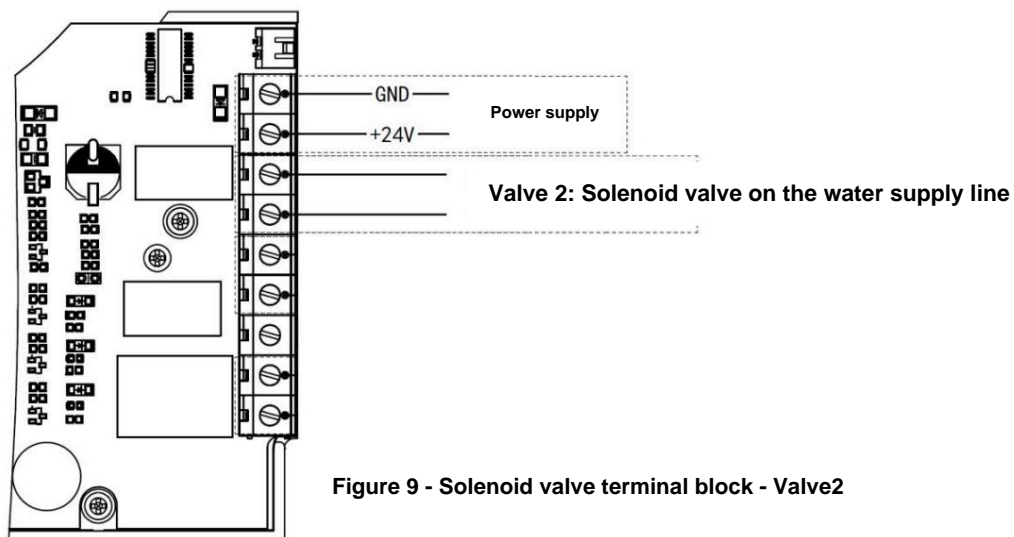

Figure 9 - Solenoid valve terminal block - Valve2

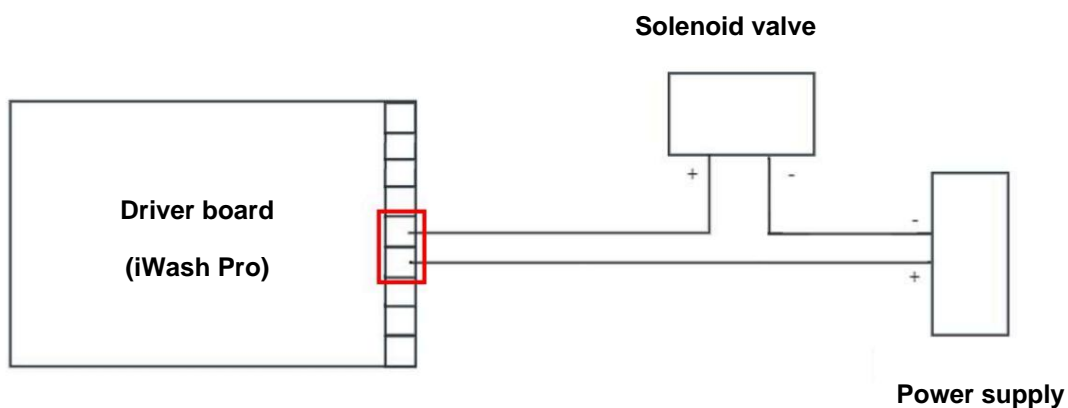

Figure 10 - Solenoid valve wiring diagram (valve 2)

### 5.2.2 Blocking the single-speed pump end

The terminal block of the single-speed pump is contactless. Nominal input voltage 220 V AC, maximum input current 8 A, controls the on/off of a single-speed pump.

Note: If the current is greater than 8 A, an additional AC contactor is required, which is prepared by the customer.

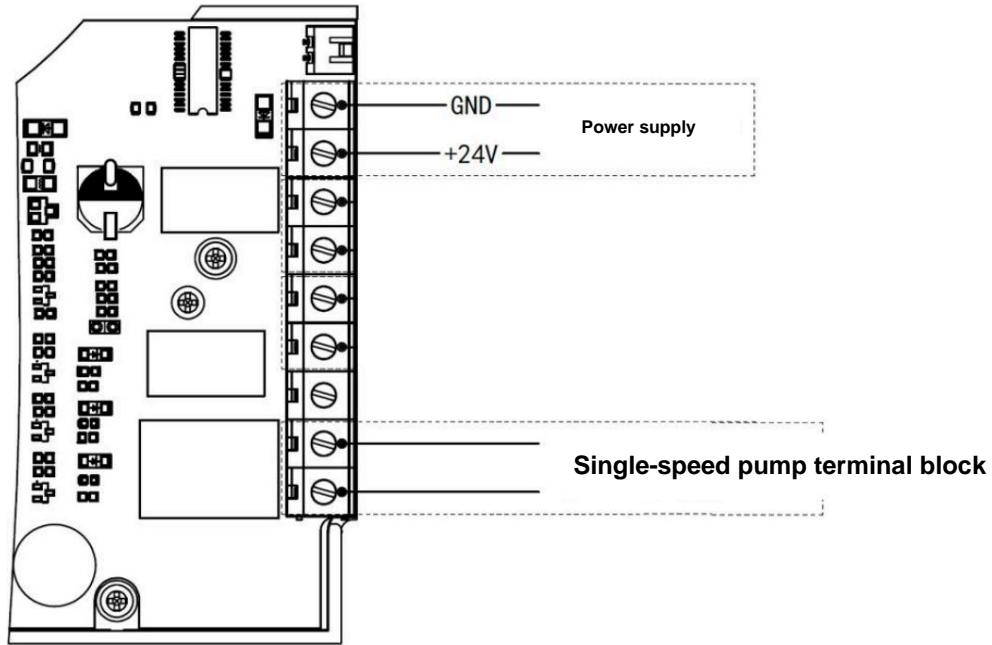

Figure 11 - Single-speed pump terminal block

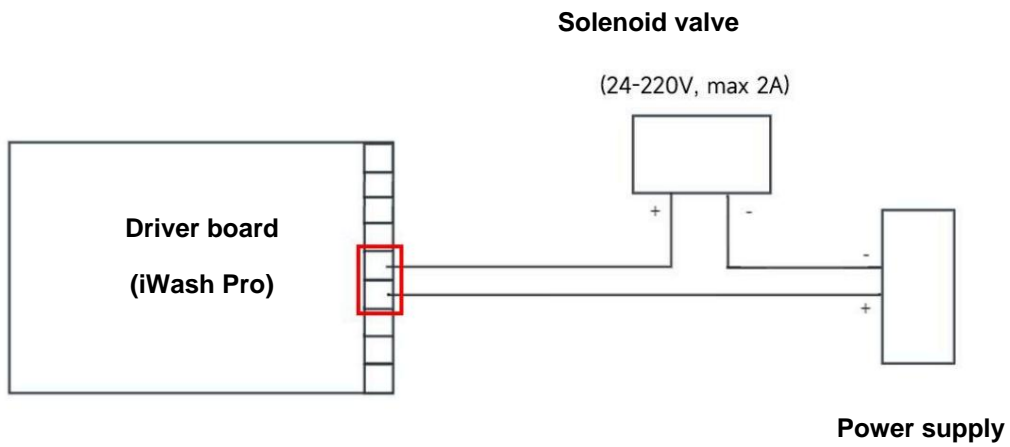
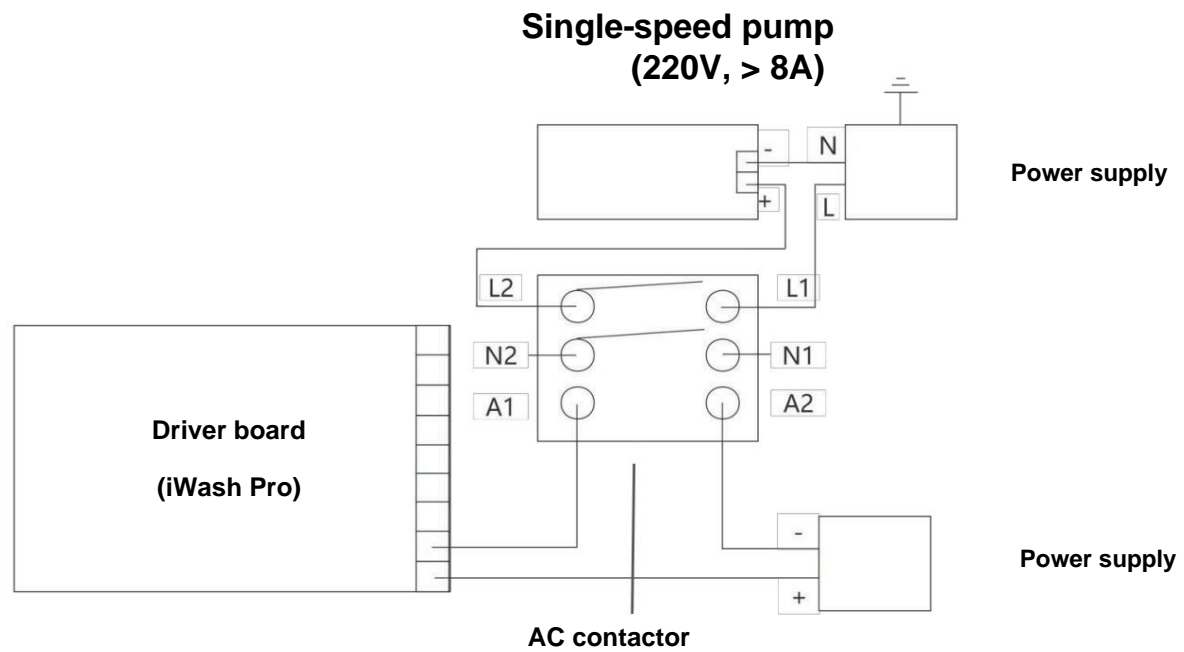

Figure 12 - Wiring diagram of a single-speed pump (current 8 A)



**Figure 13 - Wiring diagram of a single-speed pump (current >8 A)**

### 5.3 Controlling the pool pump

#### 5.3.1 Inverter pool pump (default)

**Step 1:** Connect the automatic multi-way valve and the inverter pool pump with the signal cable. (If you are not sure about the type of pool pump and its connection, please contact your local dealer.)

**Step 2:** Turn on the automatic multi-way valve. The valve will rotate to the filtration position each time it is started.

**Step 3:** Make sure the automatic multi-way valve is in filtration mode, then turn on the inverter pool pump and wait until the pump is fully primed.

**Step 4:** Press the button  to activate automatic backwash.

**Note:**

(1) When the valve is turned to other positions (except Closed), the inverter pool pump will run.

It runs at the lowest speed (30%) by default.

(2) When the valve is turned to the Closed position, the inverter pool pump will automatically stop.

### 5.3.2 Single-speed pump

Step 1: Connect the single-speed pump to the single-speed pump terminal block. (see 5.2.2)

Step 2: Turn on the automatic multi-way valve, the valve will rotate to the filtration position each time it is started.

Step 3: Make sure the automatic multi-way valve is in filtration mode, then turn on the single-speed pump and wait for self-priming to complete.

Step 4: Press the button  you activate the automatic backwash process.

Note:

(1) The default pool pump type is “0: Inverter pool pump”. If it is connected to a single-speed pump, users need to adjust the setting in parameter address No. 6 to “Single-speed pump” and restart the automatic multi-way valve. (See 4.6.1, parameter No. 6)

(2) When the valve is rotated to other positions, the single-speed pump stops.

(3) When the automatic multi-way valve is turned off, the single-speed pump stops.

### 5.3.3 Pool pump with digital input

Step 1: Connect the automatic multiport valve and the pool pump using the digital input cable.

Step 2: Turn on the automatic multi-port valve. The valve will rotate to the filtration position each time it is turned on.

Step 3: Make sure the automatic multiport valve is in filtration mode, then turn on the pool pump and wait for self-priming to complete.

Step 4: Press the button  activate the automatic backwash process.

Note:

(1) The default pool pump type is “0: Inverter pool pump”. If connecting to pool pump with digital input, users need to adjust the setting in parameter No. 6 to “2: Pool pump with digital input” and restart the automatic multi-port valve. (see 4.6.1, parameter No. 6)

(2) When the valve is rotated to other positions, the pool pump stops.

(3) When the automatic multi-port valve is turned off, the pool pump stops.

Connect a pool pump with a digital input.

Operation:

Turn on the pool pump and wait for self-priming to complete.

Turn on the automatic multi-way valve, the valve will turn to the Filter position each time it is started.

Press  you activate the automatic backflush procedure.

**Note:**

- (1) The default pool pump type is an inverter pool pump. If you are connecting to pool pump with digital input, the user must adjust the value in parameter address 6 on " 2 " (pool pump with digital input) and restart the automatic multi-way valve.
- (2) When the valve is turned to another position, the pool pump stops.
- (3) When the automatic multi-way valve is turned off, the pool pump stops.

#### **5.4 Modbus control**

The automatic multi-way valve supports control by an external device via 485-Modbus.

When using 485-Modbus control, the control panel will be invalid.

Details can be found in the Modbus user guide.

Below are two ways to activate 485-Modbus control:

I. Adjust the setting in "Parameter Address 9" to "1" and enable 485-Modbus control. (see 4.6.1, parameter

No. 9)

II. Adjust the address setting "2000H" to "1" and enable 485-Modbus control.

## 6. WIFI OPERATION (OPTIONAL ITEM)

① Download the iGarden app



② Account registration

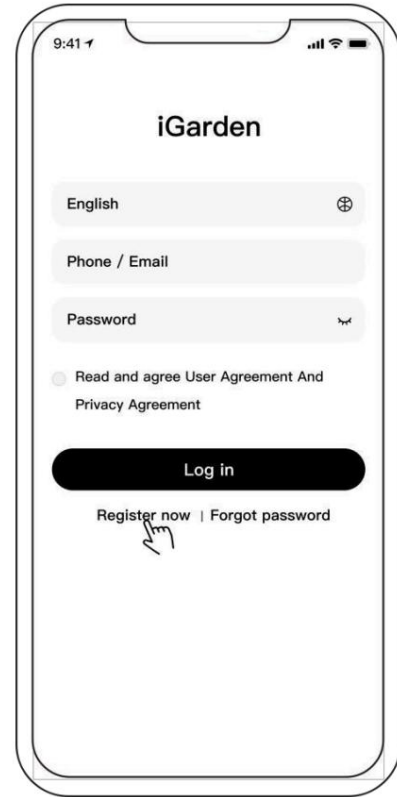

### Registration by phone / email

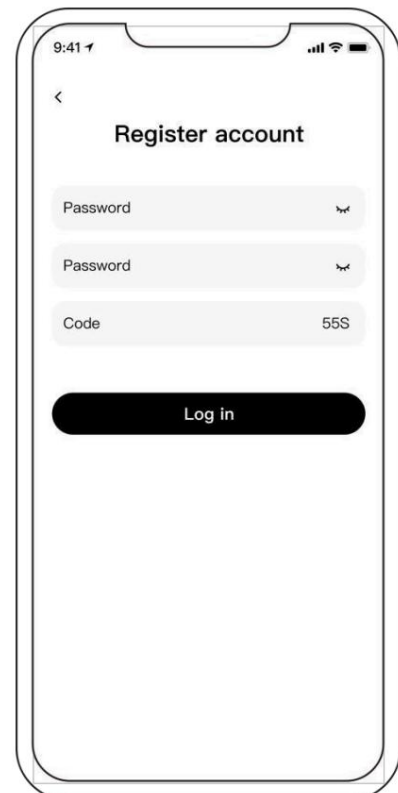
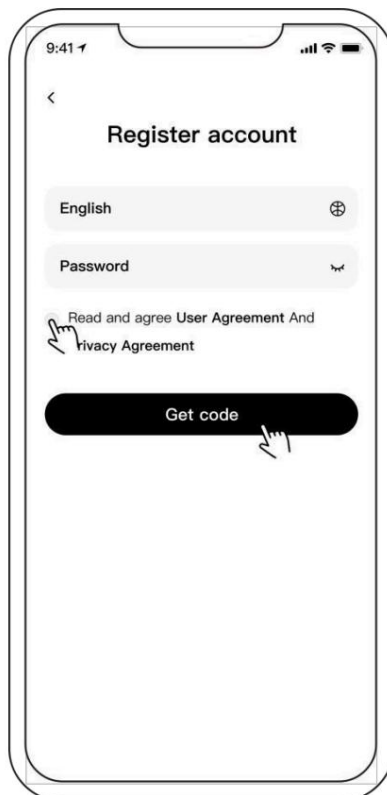

### 3 App Pairing

Before you begin, make sure your device is turned on.

Option 1 (recommended): With Wi-Fi and Bluetooth

(Network requirement: 2.4 GHz; 2.4 GHz and 5 GHz in one SSID; but no separate 5 GHz network)

1) Confirm that your phone is connected to Wi-Fi and Bluetooth is turned on.

2) Press the button  for 3 seconds until you hear a "beep" to unlock the screen.

Press the button  and  for 3 seconds until you hear a "beep", then release it.

It will start flashing.  symbol.

3) Click "Add Device" and then follow the instructions to pair the device.

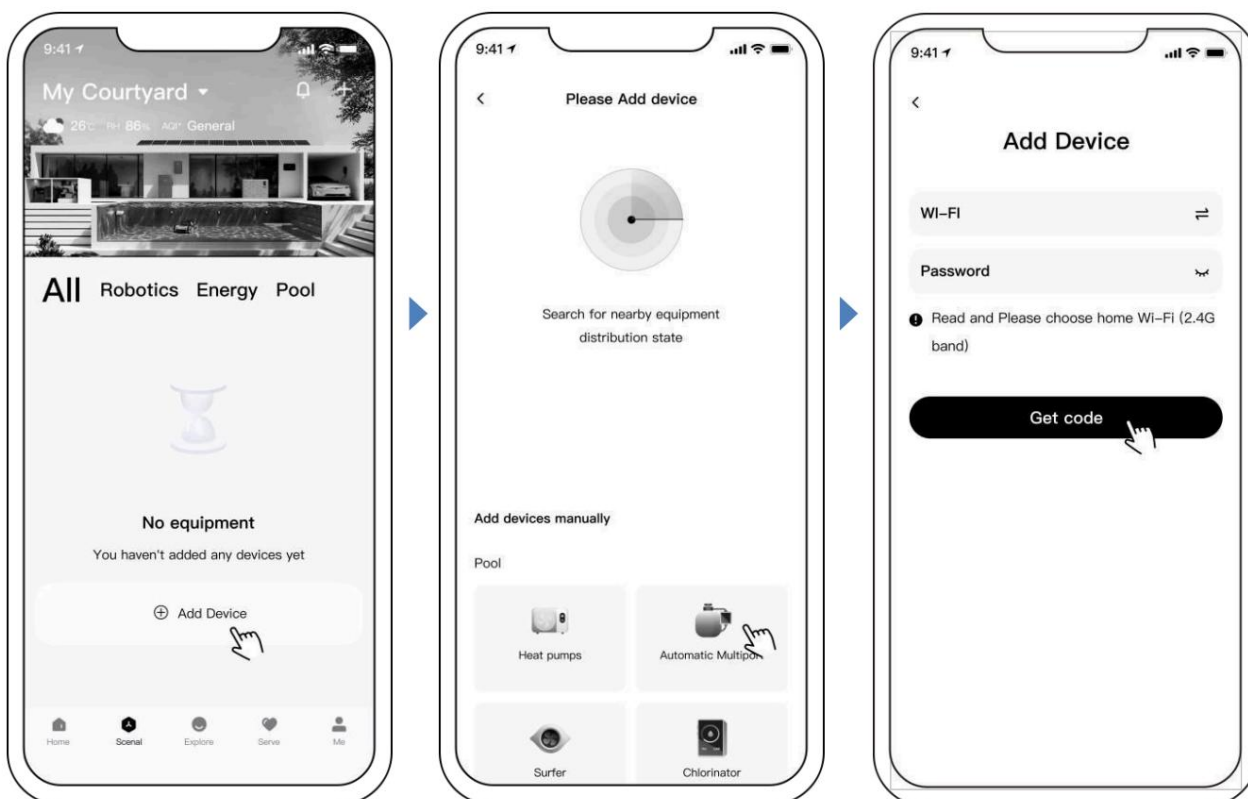

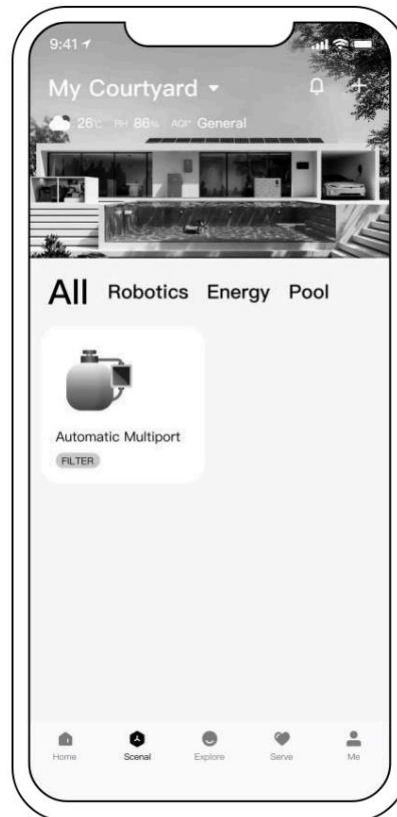

## 4 Operation

### 1) Application control interface

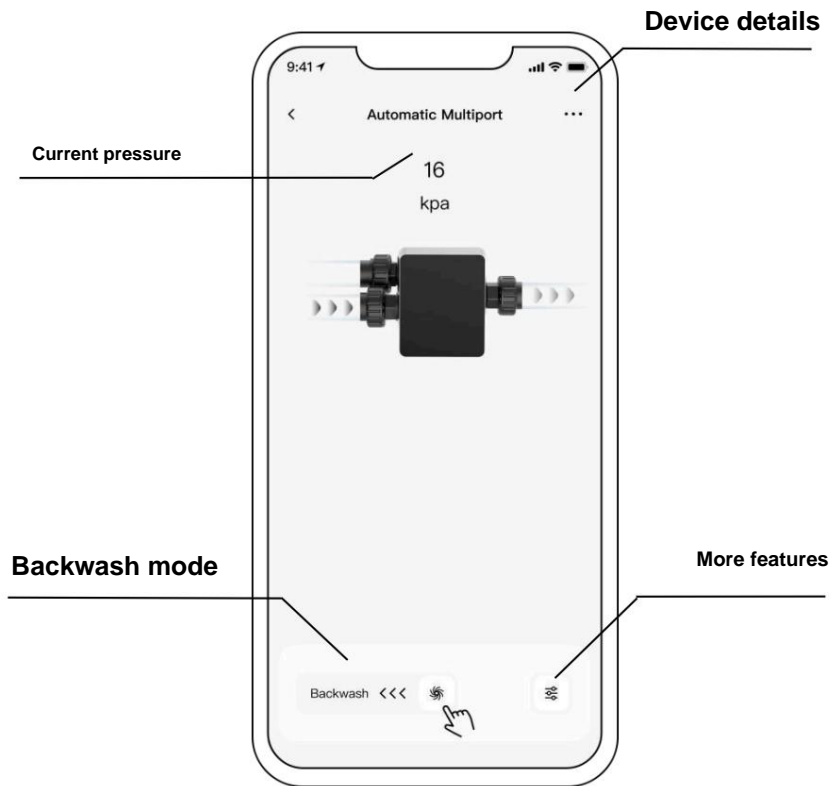

### 2) Backwash mode:

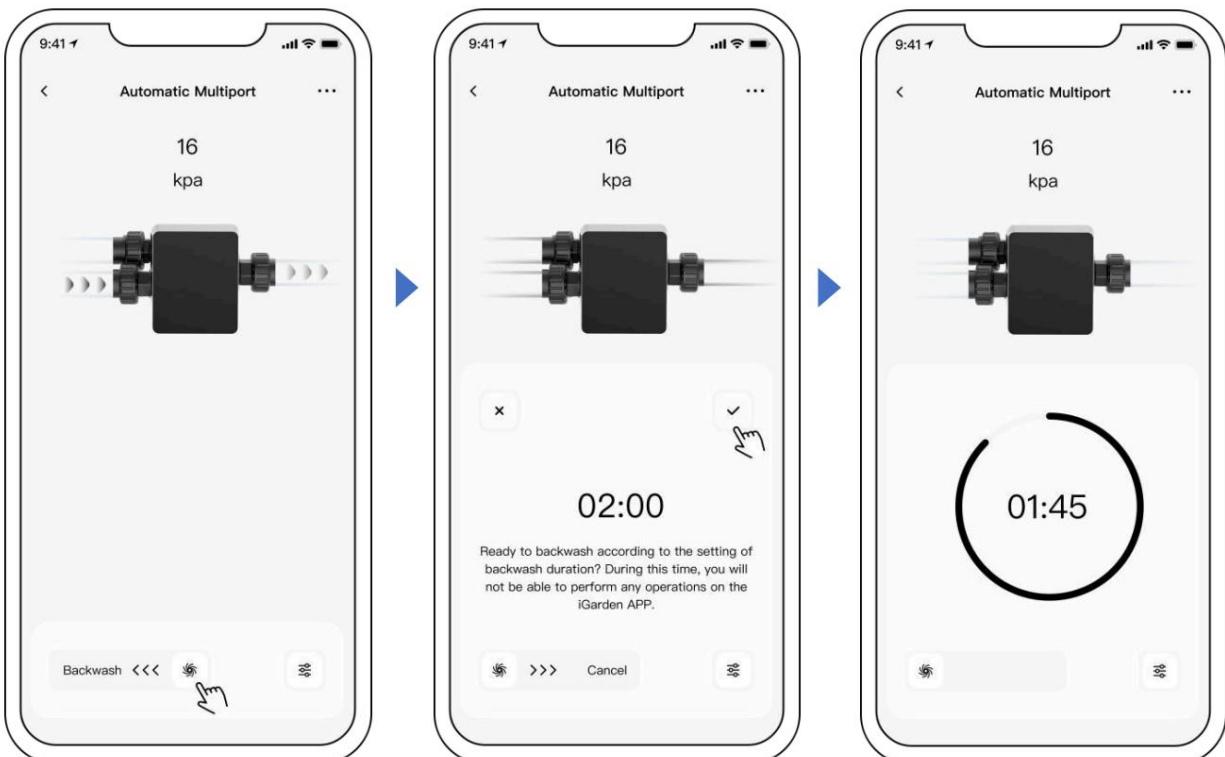

### 3) Other features:

#### 3.1. iWash function

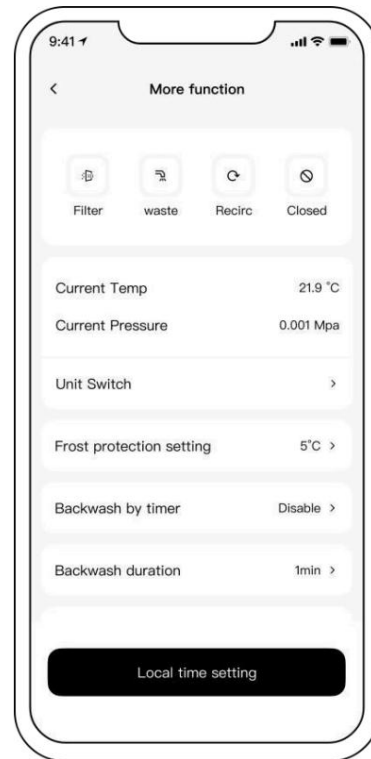
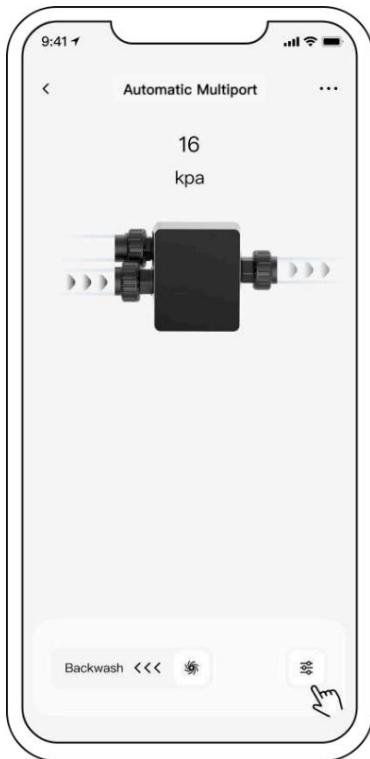

#### 3.2. Backwash with timer

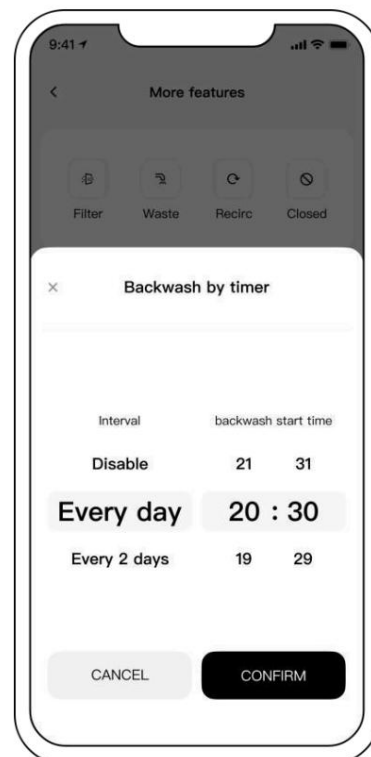
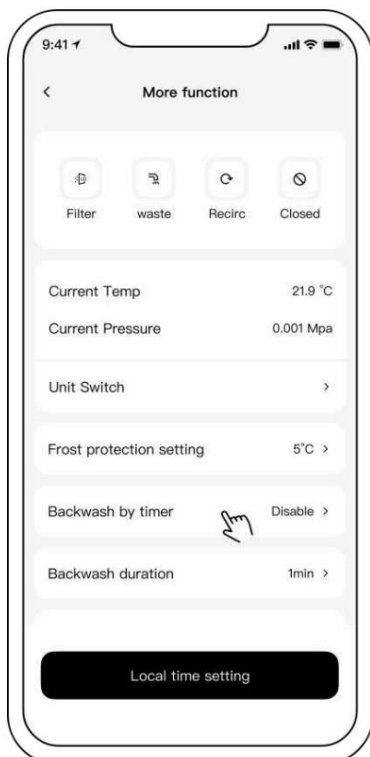

### 3.3. Backwash duration

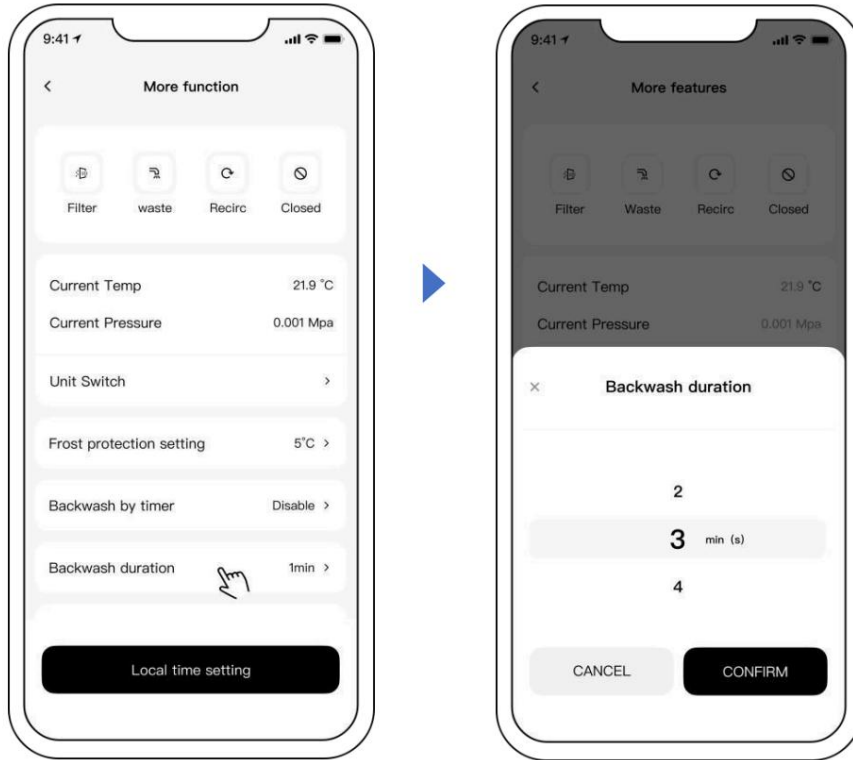

### 3.4. Setting the pump speed

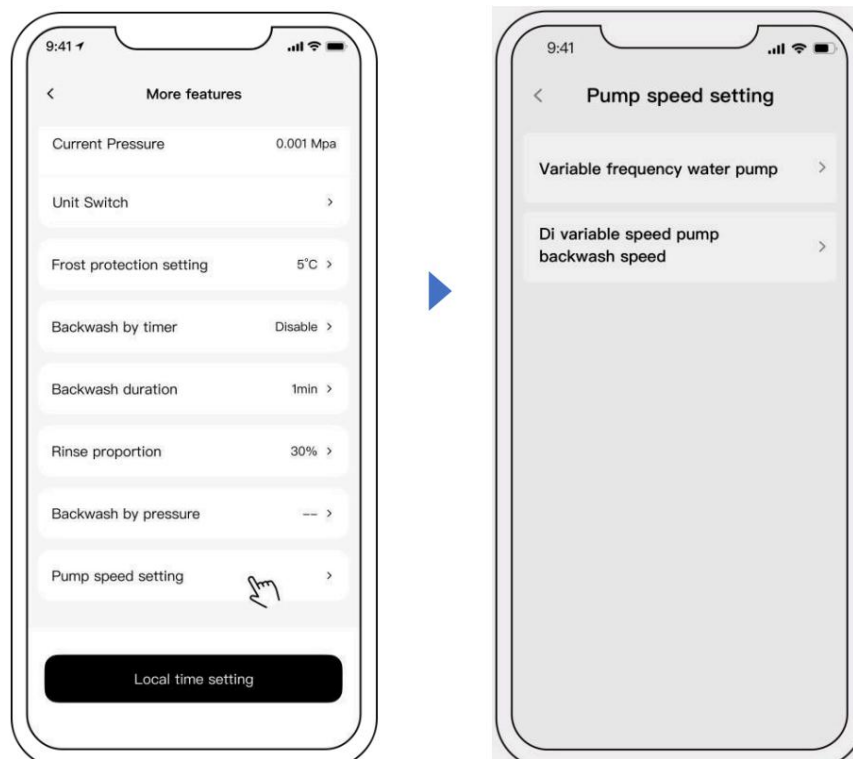

## 5 Sharing devices with family members

Users can share devices to be managed by their family members. First, please let your family members register "iGarden", and then the administrator can do as follows:

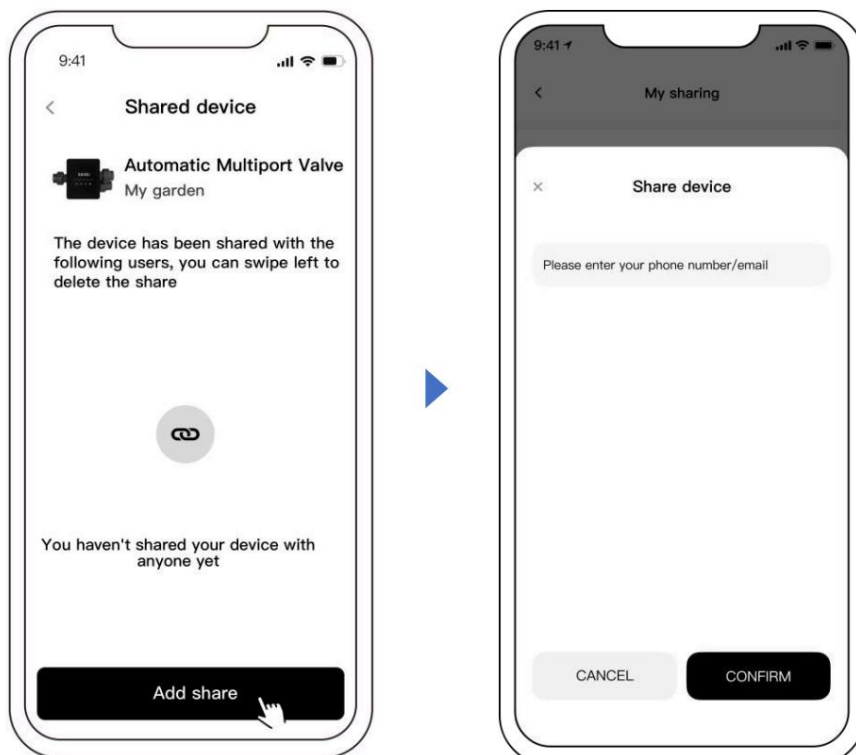
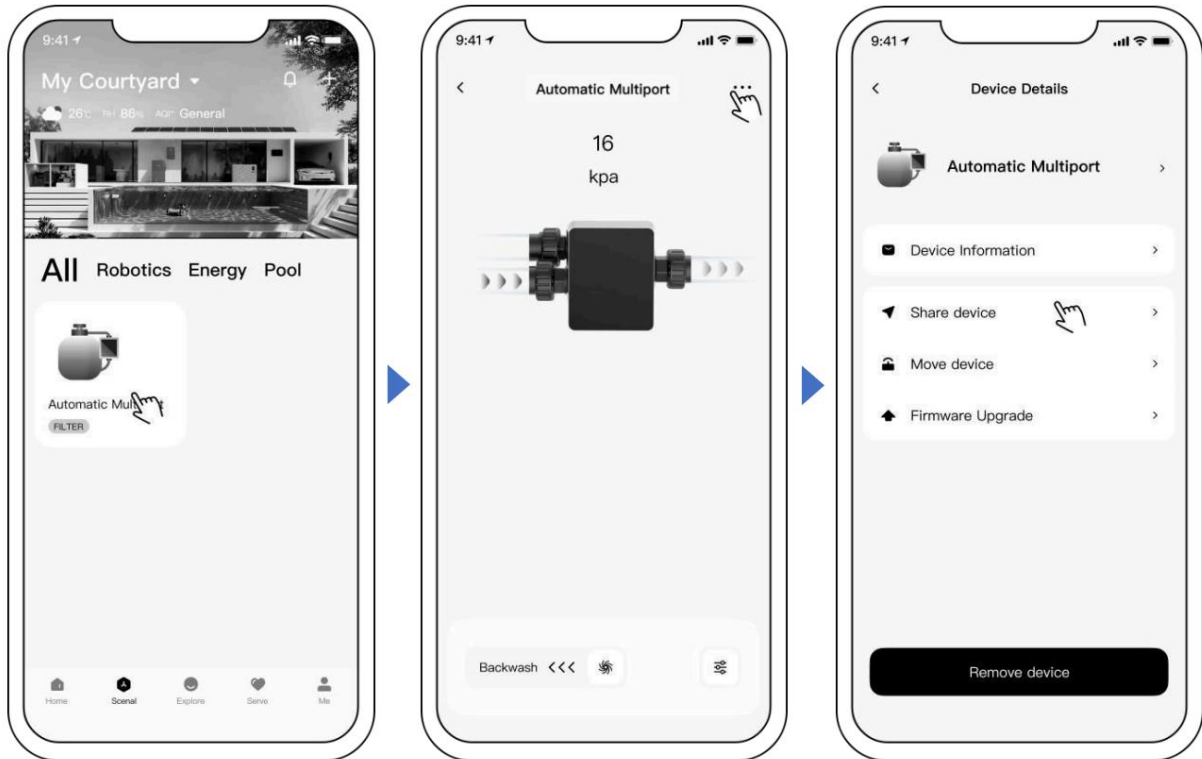

6

## Center for Garden Management and Communication

The current courtyard is displayed in the device list. After clicking, users can view/switch to all current courtyards, click Garden Management, and also enter the courtyard list page.

As shown below:

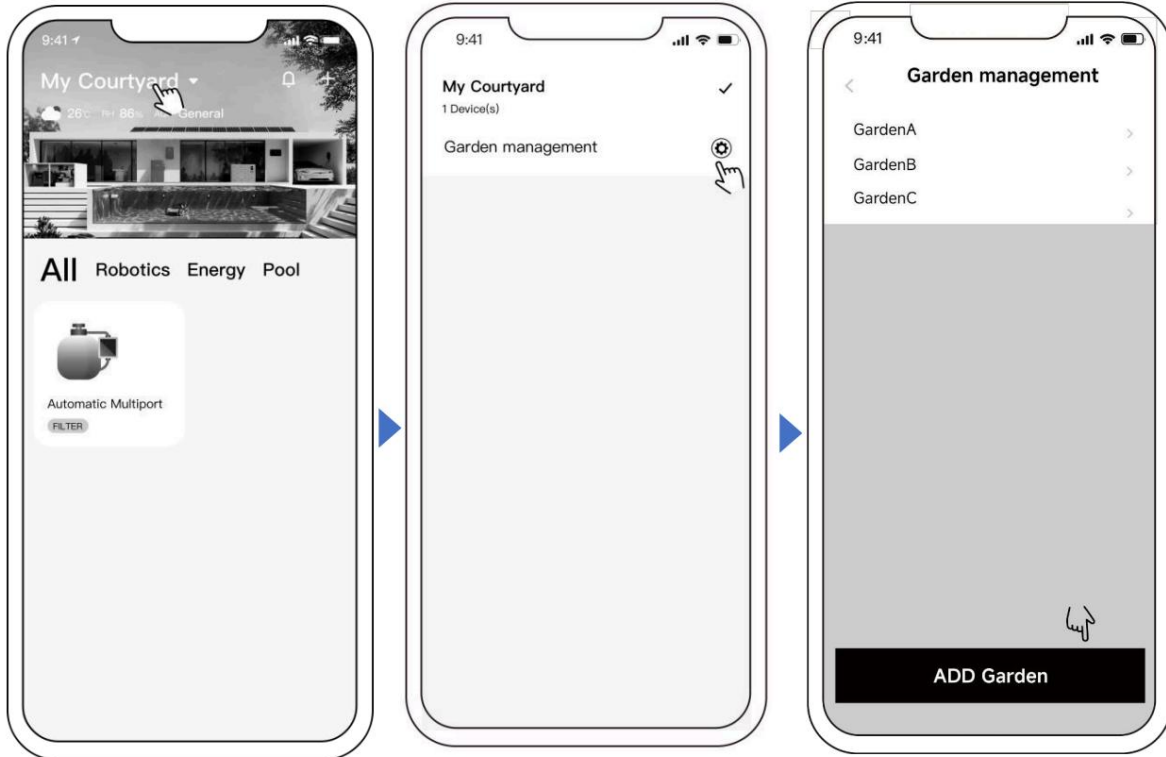

**View message:** On the device list page, click the message icon to enter the message center and view the corresponding message as below: (Including: Alarm, Garden, Notice)

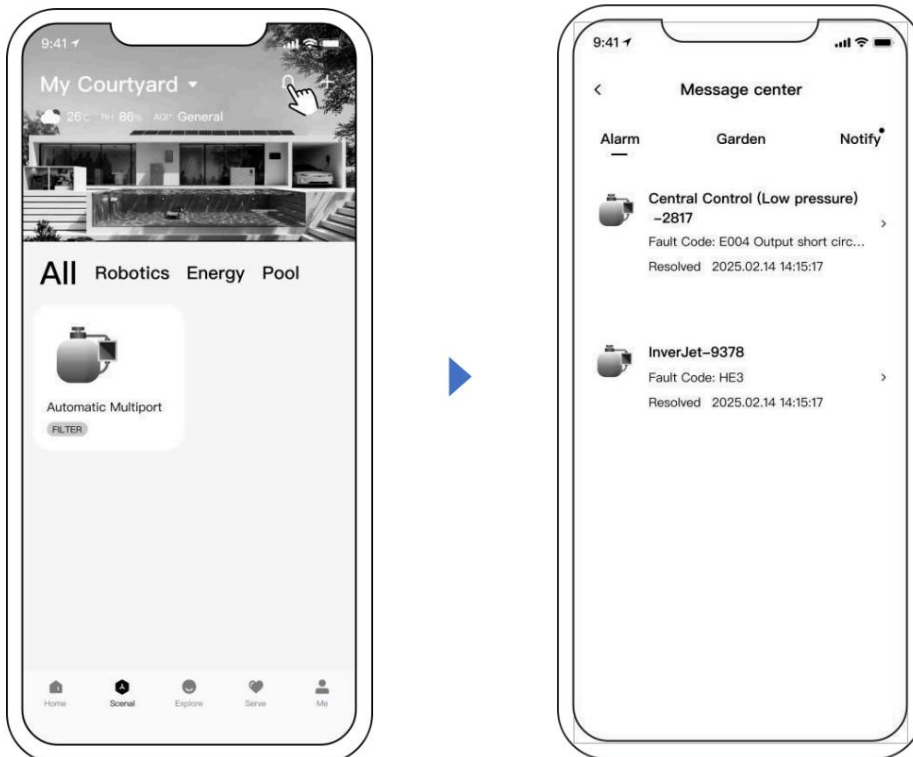

## 7 Feedback

If you have any problems using the app, please feel free to send us feedback.

**Note:** The application may be updated without prior notice.

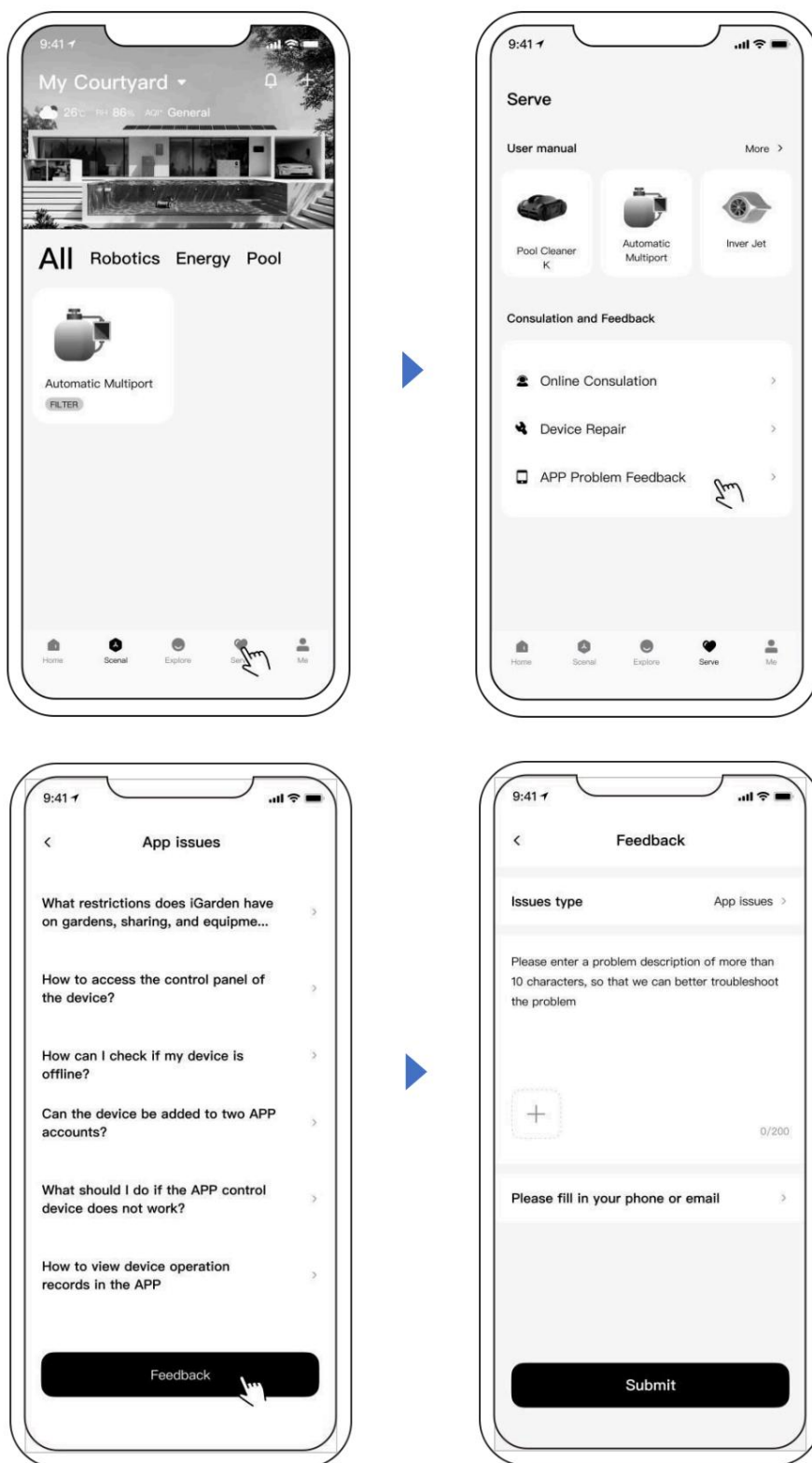

## 7. WARNINGS AND FAILURES

### 7.1 Warning

Warning code	Description	Reason
A201	Abnormal power supply voltage	A. Power supply problem
A202		B. PCB damage (after replacing the power supply)
A204	Pressure sensor not connected, automatic backflushing due to pressure function failure	A. Pressure sensor not connected B. Pressure sensor cable not connected
A206	EEPROM error	A. Circuit Interference*
A207		B. EEPROM chip damage A.
A208	The uncertainty of time, Reinitializing the RTC chip	Power failure exceeds the allowed RTC power failure time B. RTC chip failure
A209	RTC error	A. Circuit interference*
A210		B. RTC chip damage
A211		
A212	Timer is not set, timer start function is invalid	A. The current time is not set. B. Damaged RTC chip A.
A221	Temperature sensor not connected	Temperature sensor not connected B. Temperature sensor cable not connected
A222	Inverter pump speed control failure	A. Inverter pool pump started special operating mechanism A. Stop
A223	The inverter pool pump stops on command from the pump control panel	command on the control panel pumps have the highest priority
A224	Automatic water refill alarm	A. Refill time exceeds maximum permissible time. B. The float switch sensor is damaged

**Note:**

- (1) In the event of a circuit disturbance, the automatic multi-way valve will return to normal operation after the disturbance has passed. status.
- (2) The allowable RTC power failure time is no longer than 72 hours.
- (3) The pressure sensor and temperature sensor are combined into one sensor.
- (4) The permissible water replenishment time is no longer than 1 hour.

## 7.2 Failure

## 7.2.1 Valve part failure

Description	Reason	Solution
1. Automatic backwash failure	A. The pressure sensor is damaged B. Incorrect timer setting C. Damaged controller board	A. Replace pressure sensor B. Reset auto backwash timer C. Replace controller board A. Make sure center tube and O-ring are
2. Water cannot to be filtered in a filter	A. Central tube leak B. Valve body leak	not broken B. Check or replace body valve
3. Pressure loss water	A. Accumulation of impurities in the pipe leading to the filter B. Dirt build-up in the filter	A. Clean the pipe B. Clean the valve, increase the frequency of automatic backflushing.
4. The filter medium came out of the waste pipe	A. Air in the system B. Backwash flow rate too high	A. Ensure proper system venting B. Reduce backwash flow
5. The valve keeps rotates	A. Position signal line is disconnected B. Driver failure C. Stuck gear	A. Reconnect the signal line B. Replace the controller C. Remove the foreign body
5. Water keeps leaking from the drain pipe	A. Leak inside the valve B. Power failure during backwash	A. Check or replace valve body B. Close drain line and open after power is restored

## 7.2.2 Controller failure

Code errors	Description	Reason	Solution
E031	Position detection error	A. Connection failure between positioning plate and plate driver.	A. Replace the positioning board and board connection cable drivers.
E032		B. Damage to the positioning board C. Damage to the driver	B. Replace the positioning plate C. Replace the controller board
E034	Mode switching timeout because the valve does not rotate	board A. Connection failure between motor and controller board	A. Replace the connecting cable between the motor and the controller board
E035		B. Mechanical damage	B. Check the mechanical gearbox
E036		C. Driver board damage	C. Replace the controller board
E037		D. Engine damage	D. Replace the controller board
E038	Communication failure pump controllers	A. Communication failure with inverter pump B. Damaged pump controller	Replace the motor A. Replace the connecting cable between the pump and the board drivers.

		C. Damaged controller board	B. Replace pump controller C. Replace controller board
E039	Driver failure pumps	Damaged pump controller	Replace the pump controller
E040	Power failure	A. Power adapter failure B. Driver board damaged C. Damaged mechanical part gearboxes	A. Check or replace the power adapter B. Replace the controller board C. Check the mechanical transmission part A. Increase the
E041			
E042			
E043			
E050	Backwash triggered by pressure times exceeding limit*	A. The pressure setting is too low	pressure set value in the parameter settings B. Replace the pressure sensors
E051		B. Damage to pressure sensors	
E200	Display board communication error*	Connection error between display and controller board	Replace the connection cable between the display and the controller board.

#### Note

If the automatic pressure backwash is activated continuously more than 3 times, the display will show error code E051. If the automatic pressure backwash is activated continuously more than 3 times in 2 hours, the display will show error code E050.

## 8. WARRANTY AND EXCLUSIONS

If a defect occurs during the warranty period, the manufacturer will repair or replace such item or part to your own mood. Customers must follow the warranty claim procedure to benefit from this warranty.

The warranty is void in the event of incorrect installation, incorrect operation, inappropriate use, unauthorized intervention or use of non-original spare parts.

The seller also will not accept complaints about mechanically damaged goods, improperly used or stored goods, goods that are heavily worn out or goods that have been used for other purposes, than was specified by the manufacturer or seller. The seller will also not accept a complaint for goods that have been installed unprofessionally or contrary to the instructions, modified or exposed to non-standard conditions influences, such as increased humidity and dustiness of the surrounding environment. For proper handling of the complaint, it is also necessary, so that the goods are delivered complete and clean.

## 9. DISPOSAL



When disposing of the product, please separate the waste products as electrical and electronic waste.

or electronic products or hand them over to your local collection point.

Separate collection and recycling of waste equipment at the time of disposal will help ensure that will be recycled in a manner that protects human health and the environment. Information

Contact your local authority for information on where you can return your automatic multi-way valve for recycling.

MANUFACTURER:

**AQUAGEM**<sup>®</sup>

AQUAGEM MANUFACTURING LTD,

Suite 101, Building 15, Suite 401, 501, Building 16, No. 193, Jinlong Road, Dalong street, Panyu, Guangzhou,

China

[www.aquagem.com](http://www.aquagem.com)

Importer:

POOLTECHNIKA sro

Nebovidy 220, Nebovidy, 664 48, Czech Republic

[pooltechnika@pooltechnika.cz](mailto:pooltechnika@pooltechnika.cz)

