

WYBOT

USER MANUAL HANDHELD POOL VACUUM

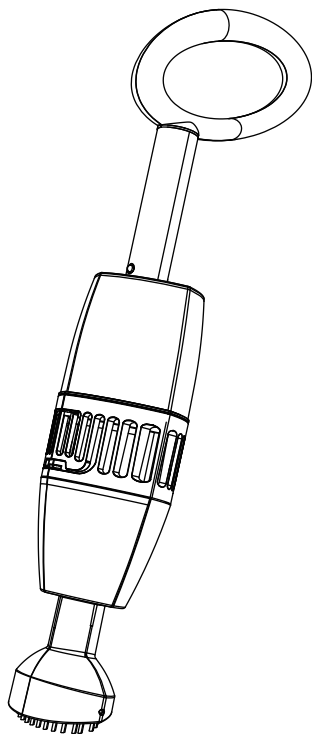

Hyson 100 (HJ10P)

Thank you for purchasing WYBOT™ Robotic Pool Cleaner. Please read through the entire manual before using your new robotic pool cleaner. We are not held liable for any loss or injury caused by improper use. If you encounter a problem with your WYBOT™ product, please contact our customer service for assistance.

Wybot Customer Service:

Email: support@wybotpool.com

Web: www.wybotpool.com

Facebook: [@WybotPool](https://www.facebook.com/WybotPool)

WYBOT™

CONTENTS

IMPORTANT SAFETY INSTRUCTIONS.....	2
1. Introduction	3
2. Packing List.....	3
3. Product Diagram	3
4. Specifications	4
5. Operation Instructions	5
5.1 Fully charge the battery before each use	5
5.2 Disassembly & assembly of short handle.....	6
5.3 Assembly and disassembly of telescopic aluminum pole	6
5.4 Let it clean	6
5.5 Disassembly and assembly brush head.....	7
5.6 Maintenance	8
6. Storage	9
7. Trouble Shootings.....	10
8. Warranty.....	11

IMPORTANT SAFETY INSTRUCTIONS

READ AND FOLLOW ALL INSTRUCTIONS

1. Read the manual carefully, and use the pool vacuum according to the manual. We are not liable for any loss or injury caused by improper use.
2. Only use the accessories recommended or sold by the manufacturer.
3. Do not allow children to ride on the cleaner or play with it as a toy.
4. Use the original and authorized USB charging cord only.
5. The USB charging cord should only be repaired or replaced by a qualified electrician.
6. Do not turn on the pool vacuum when it is out of water.
7. The charging adapter (not included) must be connected to an outlet protected by a ground fault circuit interrupter (GFCI) and an earth leakage interrupter (ELI).
8. Do not operate the pool vacuum when there are people in the pool.
9. Always clean and wash the filter tray after use.
10. Turn off the pool vacuum when maintaining, cleaning or when it is not in use.
11. The pool vacuum should be stored in a cool and ventilated place, away from direct sunshine.
12. While charging, the pool vacuum should be kept in a cool place, and not be covered with anything to prevent the damage of internal electrical components caused by overheating.
13. Only certified professionals can disassemble the sealed driving kit of the pool vacuum.
14. Do not operate the pool vacuum while pool filter is running.
15. Oil seals for motor contain grease, which may cause water pollution if grease leakage occurs.
16. When the pool vacuum is stored for a long period of time, it should be charged every three months to maintain battery life between 40%-60%. Please use the original and authorized USB charging cord only. If the pool vacuum is not charged for a long time, the battery voltage will be lower than the over-discharge protection voltage due to the self-discharge of the battery, which may cause fatal damage.
17. Do not use or store the pool vacuum near any heat source.
18. Do not pierce the shell of the pool vacuum with nails or other sharp objects. Do not hammer, impact, or throw the cleaner.
19. Make sure the charging socket is dry before charging.
20. Charge the pool vacuum before the battery completely runs out.
21. Do not overcharge the pool vacuum when the battery is fully charged. Overcharging will reduce battery life.

SAVE THESE INSTRUCTION

1. Introduction

The environmentally-friendly handheld pool vacuum Hyson 100(HJ10P) is a new type of rechargeable pool vacuum that keeps pool water clean by vacuuming out dirt and debris.

2. Packing List

Item	Name	QTY	Remark
1	Pool Vacuum	1 PC	In carton
2	USB Charging Cord	1 PC	In plastic bag
3	Telescopic Aluminum Pole	1 SET	In carton
4	Handle	1 PC	In carton
5	User Manual	1 PC	In plastic bag
6	Brush head	2 PC	In carton
7	Quick Start Guide	1 SET	In plastic bag

3. Product Diagram

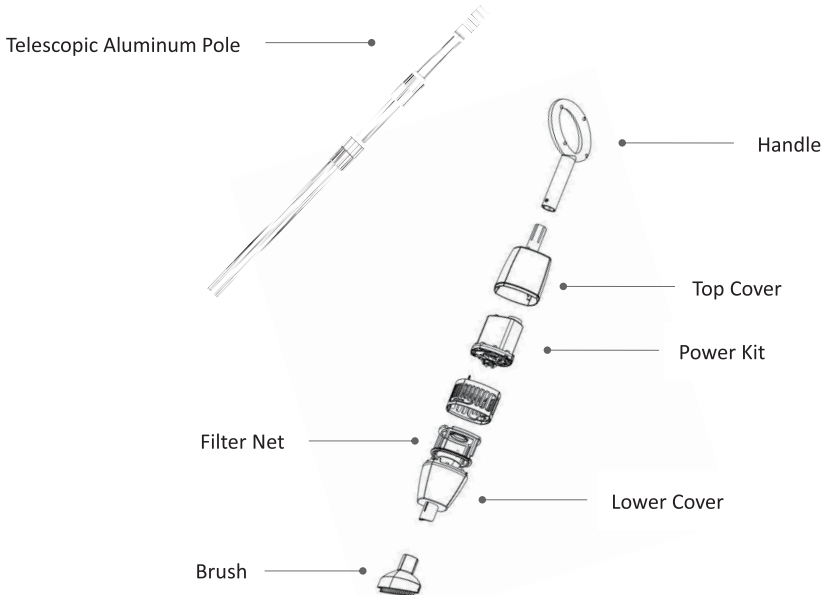

4. Specifications

Product Name	WYBOT Handheld Pool Vacuum
Pool Type	Spa, hot tub, pool steps, pool corners
Model	Hyson 100 (HJ10P)
Rated Working Voltage	4.2V
Power	approx. 15W
Working Cycle	max. 60min
Battery Capacity	5200mAh
Charging Time	4-5 H
Filter Capability	approx. 5.5gal/min (25L/min)
Filter Density	250µm
IP Grade	IPX8
Pool Water Temperature	50°F-95°F / 10°C-35°C
Charging Environment Temperature	50°F-95°F / 10°C-35°C
Storage Temperature	41°F-95°F / 5°C-35°C
Product Weight	2.65lb / 1.2kg (without aluminum pole)
Product Size	17.3 (L) * 5.2 (W) * 4.3 (H) in / 440 (L) * 132 (W) * 110 (H) mm

5. Operation Instructions

5.1 Fully charge the battery before each use

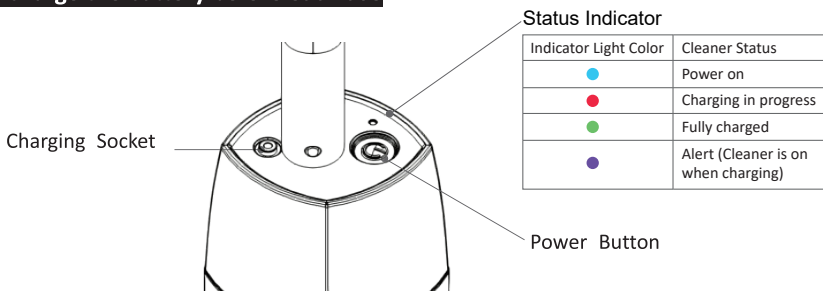

- a. Connect provided USB charging cord to charger USB socket and plug the charger into the main electrical outlet.

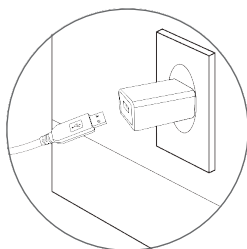

- b. Connect the small end of the USB charging cord into the charging socket on the vacuum body.

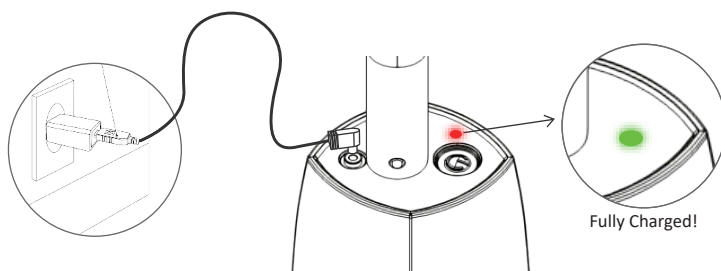

NOTE: Charger is not included. Use a standard USB-A plug charger with an output of 5V DC, 1A/2A.

NOTE: Make sure the vacuum is powered off before charging, and no ● light appear on the cleaner.

Note: If no ● light appears when charging, please press the power button again to turn off the device. If still no light indicates, please contact after-sale team for help.

NOTE: Make sure the charging socket on the pool vacuum is dry before charging.

5.2 Disassembly & assembly of short handle

a. Detach the short handle pole by squeezing the spring buttons and take out the short handle.

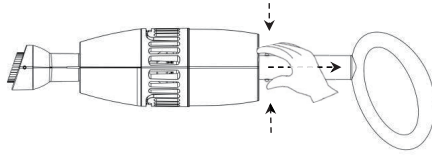

b. Attach the short handle pole by squeezing the spring buttons and inserting into handle of the vacuum body. Check the buttons “pop” into the holes.

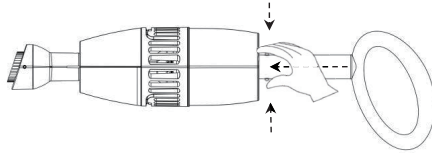

5.3 Assembly and disassembly of telescopic aluminum pole

a. Attach the aluminum pole by squeezing the spring buttons and inserting into pole of the vacuum body. Check the buttons “pop” into the holes. Adjust the length of the shaft by unlocking, extending and locking each section accordingly.

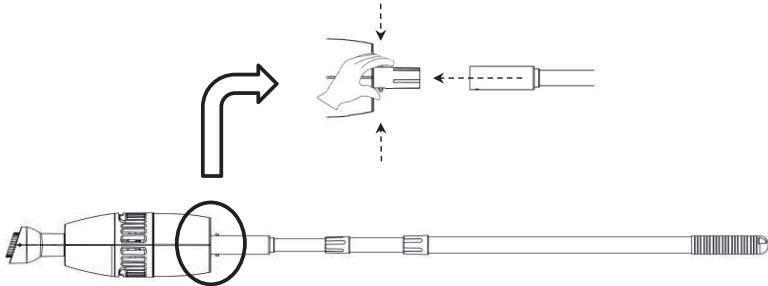

b. Detach the aluminum pole with the assembly instruction in reverse (refer to section 5.3 a).

5.4 Let it clean

a. Power on the pool vacuum after it is fully submerged in water. The indicator light turns ●

NOTE: Make sure the charging socket is securely covered with the rubber flap.

b. Carefully clean the surface of the pool or spa to remove debris.

c. Power off the pool vacuum once you stop cleaning.

NOTE: Charge the pool vacuum before the battery completely runs out.

5.5 Disassembly and assembly brush head

a. Lift up the brush head and pull it out. This type is ideal for vacuuming the dead corner.

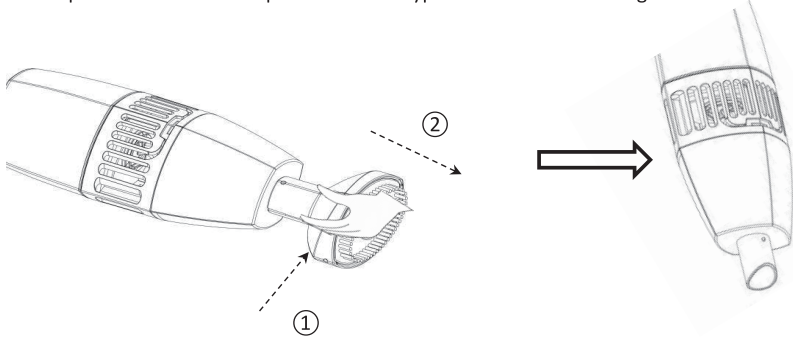

b. Insert the brush head into the pole of the vacuum body when you want to brush somewhere in the pool or spa with the pool vacuum.

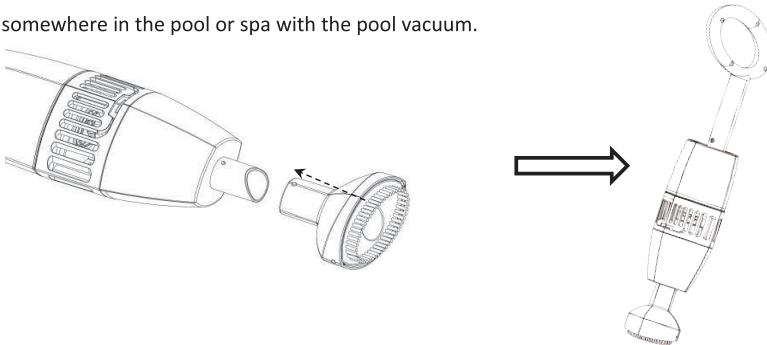

5.6 Maintenance

- a. Power off the vacuum before cleaning, servicing and maintenance.
- b. Disassembly of filter net

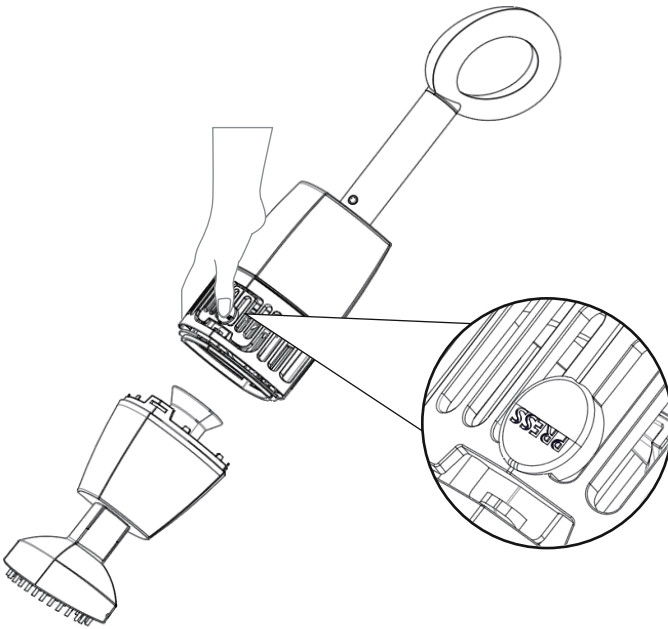

c. Filter cleaning

Take out the filter and clean with water.

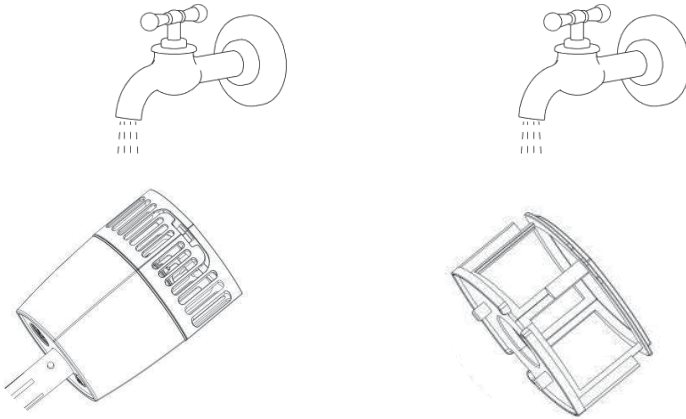

d. Assembly the filter net with the disassembly instruction in reverse (refer to section 5.6 b).

WARNING: DO NOT put your hand inside the upper part of the vacuum body when installing the filter.

6. Storage

Please refer to the following instructions before and during long-term storage:

- Store the product and accessories in a dry, temperature controlled, between 41°F-95°F / 5°C-35°C, storage location.
- The original packing can be used for storage.
- It should be charged every three months to maintain battery life between 40%-60%. Please use the original and authorized USB charging cord only. If the pool vacuum is not charged for a long time, the battery voltage will be lower than the over-discharge protection voltage due to the self-discharge of the battery, which may cause fatal damage.

7. Trouble Shootings

Scenario	Possible reasons	Solutions
Power on the vacuum and submerge it in the water but it does not work	Battery level is low	Recharge the battery
	Filter net is not installed or Lower cover is installed improperly	Refer to the assembly instructions
Power on the vacuum and submerge it in the water but it stops working after 30-60 seconds	Battery level is low	Recharge the battery
Power on the vacuum and submerge it in the water but it stops working suddenly	The vacuum gets stuck by the debris	Take out, clean and reinstall the filter, and power on the vacuum
The vacuum cannot suck the debris	Battery level is low	Recharge the battery
	The impeller gets stuck by the debris	Power off the vacuum, then clean the impeller
	The impeller is damaged	Call customer service and request for a replacement impeller
	The container is full	Clean the filter container
	Others	Call customer service
The debris leaks from filter	The filter net is damaged	Call customer service and request for a replacement filter net

The indicator lamp on the USB charging cord shows red all the time when charging	The USB charging cord is damaged	Call customer service and request for a replacement USB charging cord
The indicator lamp on the cleaner body shows green when charging	Poor contact between USB-A and charger	Re plug or call customer service

8. Warranty

1. This product is covered by WYBOT™ warranty for 12 months (only for motor and battery pack) from the date of purchase. Consumable parts are beyond warranty which include Filter Tray/Brush/Wheels/Nozzles.
2. This warranty is voided if the product has been altered, misused, or has been repaired by unauthorized personnel.
3. The warranty extends only to manufacturing defects and does not cover any damage resulting from mishandling of the product by the owner.
4. The order number or record must be presented for any claim or repair during the warranty period.

Environmental Programmes, WEEE European Directive

Please respect the European Union regulations and help to protect the environment.



Return non-working electrical equipment to a facility appointed by your municipality that properly recycles electrical and electronic equipment. Do not dispose them in unsorted waste bins.

For items containing removable batteries, remove batteries before disposing of the product.



尺寸：146X216mm

印刷：彩印