



VARIO Magnus **[e]Magnus**

INSTALLATION AND MAINTENANCE MANUAL

Index

1 Safety rules.....	21
2 Technical data.....	22
3 Installation and assembly	22
4 Electrical connections	23
5 Screen format	24
6 Main screen.....	25
7 Operation mode	25
8 First start-up	26-27
9 Parameters menu (diagram).....	28-30
10 Setup menu.....	31-36
11 Alarms.....	37
12 Warranty	38
13 Disposal and environmental aspects.....	38
14 Declaration of conformity.....	38



1 SAFETY RULES

Before installing and using the product:



- Carefully read the whole of this manual.
- Check that the data indicated on the plate is desired information and is appropriate for the installation, and in particular that the nominal voltage of the pump is compatible with that of the installation.
- The installation and maintenance must be carried out solely and exclusively by authorised personnel, responsible for making the electrical connections in accordance with the current safety regulations.
- The pump must not be used by people with reduced physical, sensory or mental capabilities, or without the due experience or knowledge, except if a person responsible for their safety has explained the instructions and supervised their operation of the pump.
- Do not let children play with the pump.
- The manufacturer accepts no liability for damage caused by improper use of the product and shall not be held responsible for damage caused by maintenance or repairs carried out by unqualified staff and/or with non-original replacement parts.
- The use of unauthorised replacement parts, alterations of the product or improper use shall automatically render the product guarantee null and void.

During normal operation:



- Before removing the cover of the variator, connect the mains voltage and wait 5 minutes for the electronic circuit board to discharge any residual voltage inside.
- Never disconnect the variator while the motor is rotating. This action can cause irreparable damage to the speed variator and affect the other electronic systems connected to the same electric grid.
- Although the pump is not operational, the electrical supply must still be cut off to the whole variator for any maintenance work.
- If there are any anomalies in the installation, the speed variator can be stopped manually using the button STOP for this purpose.
- If the inputs and outputs of the speed variator have not been wired, ensure the cable glands are tightened properly, so that the electronics of the speed variator remain sealed from the moisture in the room.

2 TECHNICAL DATA

Nominal values:

Power supply voltage (V)	400 V (3~ - 50/60 Hz)
Working frequency (Hz)	10 Hz – 50 Hz
Maximum current (A)	11 A
Protection rating	IP 55

Limits of use:

- Minimum ambient temperature: -10°C
- Maximum ambient temperature: +40°C
- Variation in the supply voltage: +/- 10%

3 INSTALLATION / ASSEMBLY



BEFORE INSTALLING THE PUMP, CAREFULLY READ THE WHOLE OF THIS MANUAL AND CONSULT THE SAFETY RULES VALID IN EACH COUNTRY.

Installation of the pump:

- It must be installed in a well ventilated area, protected from damp and direct exposure to the sun and rain.
- Before making the electrical connections, ensure the cable used to provide power to the pump is not live.
- Carefully verify the electrical data indicated in the specifications plate of the speed variator before connecting the electric current.
- The electric power cables to the pump must be of the correct size for the nominal consumption of the motor and the length of cable required.
- Also ensure that the grid has electrical protection; a high-sensitivity differential switch (30 mA, class B for industrial applications) is particularly recommended.
- In addition to the differential switch, it is advisable to install magnetothermal protection and a voltage disconnect switch to control the power supply to the pump.

4 ELECTRICAL CONNECTIONS

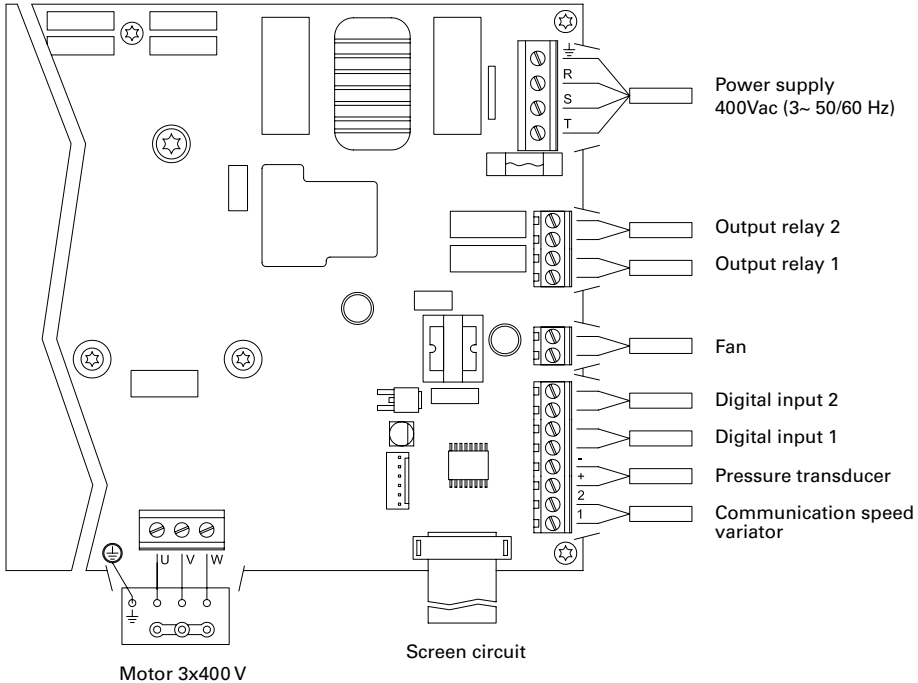

Signal	Description
Outputs relay 1 and 2	Outputs that acts depending on how they have been programmed. These outputs are potential free and have a maximum load of 5 amperes at 230 Vac.
Fan	When wall-mounted, as there is no cooling from the motor's own fan, the ventilation system of the wall mounting shall be used for this cooling. This output is 24 Vdc and it is activated whenever the variator is giving a voltage output; its maximum load is 9 W. <u>N.B. It is very important to check the polarity of the variator cables when they are connected, as if they are connected against the polarity, the speed variator can burn out.</u>
Digital intakes 1 and 2	Any potential free contact that will perform the programmed functions can be connected to these inputs. <u>N.B. Do not apply voltage to these inputs.</u>
Pressure transducer	If it is connected, it will be used by the speed variator to determine the pressure of the installation as well as the pressure during the "BACK WASH" cycle.
Communication between speed variators	This enables communication between various speed variators (up to 8) through a 2-wire point-to-point cable.

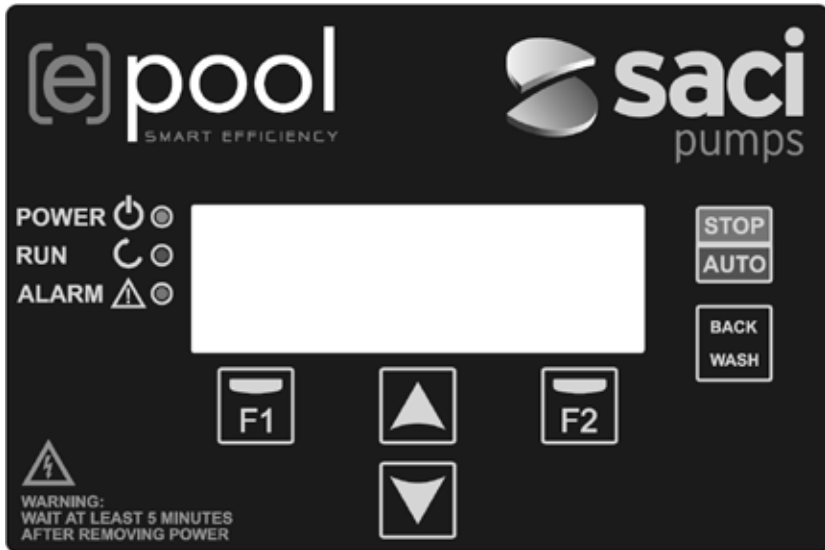

KEY	FUNCTION
STOP/AUTO	To disable/enable the pump at any time
BACK WASH	To initiate the filter cleaning cycle (back wash)
F1	Key to activate the text on the screen
F2	Key to activate the text on the screen
▲ ▼	Keys for moving around the menu
POWER	Indicates voltage
RUN	Indicates that the pump is operating
ALARM	Indicates that there is an active alarm

6 MAIN SCREEN

This screen will show the current status of the pump:

	S	A	C	I		P	U	M	P	S	<	e	>	p	o	o	l				
H	z			3	5	.	0			B	a	r		0	.	8					
A	m	p		4	.	1				(8	.	0)							
1	5	:	5	9						(M	2)					M	e	n	u

You can directly view the instantaneous rotational frequency of the motor, the pressure of the installation (only if the pressure transducer is installed) and the instantaneous consumption of motor. In brackets, just to the side of the instantaneous consumption, you can see the nominal consumption of the motor entered in the start-up wizard (point 8 of this manual).

From this screen, if you click on the keys (▲) or (▼), you can directly access the display menu. This acts a short cut for checking data you need view without having to access the settings menu.

7 OPERATION MODE

Like all pumps designed for swimming pool filtration, its main objective is to keep the water clean and in optimum condition. Its main characteristic and new feature is that, with the logic of the speed variator, this process achieves high energy savings thanks to simple and intuitive management software, providing greater protection for the pump, and completely eliminating the need to install a conventional electric panel.

The system it allows one single pump to operate in an installation, or a variety of pumps connected together in parallel (up to 8 pumps) using its speed variator.

We have a daily setting of various filtration sequences (up to 4 sequences every day), in which we can also indicate how many pumps participate in this filtration (if there is more than one pump installed), and the operating frequency of the pumps.

You can configure the settings for the days needed from the menu to alternate the operation of the pump(s) that will be involved in the filtration (from 1 day to 14 days).

The default of pump operation mode is filtration. Once time bands and the days of the week on which filtering is required have been indicated, the pump(s) will filter at the frequency indicated for each band. It is here where we must take into account that the longer the time the greater the energy savings.

If there is a pressure transducer installed, the system will monitor the pressure of the installation at all times, to warn if it detects excess soiling in the filter. Once this warning has been received, or at any other time, when the button "BACK WASH" is pressed, a simple wizard will guide you through the installation filter cleaning. This wizard will tell you to move the filter valves to cleaning mode, then rinse and finally back to filtration.

With the keys (▲) and (▼) you can increase and decrease, respectively, the number of pumps that are involved in each filtration cycle, leaving the rest of the pumps in the network on “standby”, ready to work when the alternating cycle is completed. Use the F2 key to move on to menu 1.5.

1	.	5	M	A	X	F	I	L	T	E	R				
			P	R	E	S	S	U	R	E					
			4	.	0	B	a	r							
B	a	c	k								N	e	x	t	

With the keys (▲) and (▼) you can increase and decrease, respectively, the maximum filter pressure, which is significant above all for detecting excess soiling in the filter or if it has burst. Use the F2 key to move on to menu 1.6.

			R	O	T	A	T	I	O	N	C	O	R	R	E	C	T	?
							Y	E	S									
							N	O										
R	e	p	e	a	t						O	k						

This screen shows a sequence of starting and stopping the motor at low speed, to be able to see if the motor is rotating in the correct direction. If it is not, the keys (▲) and (▼) invert the rotation direction.

This is the last screen of the start-up wizard, and it is the only one that must be done individually for each of the pumps that make up the filtration pump network, as it is independent for each model. The rest of the parameters entered in the wizard are automatically copied from one pump to the next.

9 SETUP MENU (DIAGRAM)

1 PARAMETERS	1.1 LANGUAGE	1.4 NUMBER OF PUMPS PER CYCLE
	1.2 SET DATE AND TIME	1.5 MAXIMUM FILTER PRESSURE
	1.3 MOTOR CURRENT	1.6 ROTATION DIRECTION
2 CICLOS	2.01 NUMBER OF BANDS MONDAY	2.33 EDIT BAND WEDNESDAY (2)
	2.02 EDIT BAND MONDAY (1)	2.34
	2.03	2.35
	2.04	2.36 EDIT BAND WEDNESDAY (3)
	2.05 EDIT BAND MONDAY (2)	2.37
	2.06	2.38
	2.07	2.39 EDIT BAND WEDNESDAY (4)
	2.08 EDIT BAND MONDAY (3)	2.40
	2.09	2.41
	2.10	2.42 COPY DAY WEDNESDAY TO THURSDAY
	2.11 EDIT BAND MONDAY (4)	2.43 NUMBER OF BANDS THURSDAY
	2.12	2.44 EDIT BAND THURSDAY (1)
	2.13	2.45
	2.14 COPY DAY MONDAY TO TUESDAY	2.46
	2.15 NUMBER OF BANDS TUESDAY	2.47 EDIT BAND THURSDAY (2)
	2.16 EDIT BAND TUESDAY (1)	2.48
	2.17	2.49
	2.18	2.50 EDIT BAND THURSDAY (3)
	2.19 EDIT BAND TUESDAY (2)	2.51
	2.20	2.52
	2.21	2.53 EDIT BAND THURSDAY (4)
	2.22 EDIT BAND TUESDAY (3)	2.54
	2.23	2.55
	2.23	2.56 COPY DAY THURSDAY TO FRIDAY
	2.25 EDIT BAND TUESDAY (4)	2.57 NUMBER OF BANDS FRIDAY
	2.26	2.58 EDIT BAND FRIDAY (1)
	2.27	2.59
	2.28 COPY DAY TUESDAY TO WEDNESDAY	2.60
	2.29 NUMBER OF BANDS WEDNESDAY	2.61 EDIT BAND FRIDAY (2)
	2.30 EDIT BAND WEDNESDAY (1)	2.62
	2.31	2.63
	2.32	2.64 EDIT BAND FRIDAY (3)

9 SETUP MENU (DIAGRAM)

2 CICLOS

2.65	2.82
2.66	2.83
2.67 EDIT BAND FRIDAY (4)	2.84 COPY DAY SATURDAY TO SUNDAY
2.68	2.85 NUMBER OF BANDS SUNDAY
2.69	2.86 EDIT BAND SUNDAY (1)
2.70 COPY DAY FRIDAY TO SATURDAY	2.87
2.71 NUMBER OF BANDS SATURDAY	2.88
2.72 EDIT BAND SATURDAY (1)	2.89 EDIT BAND SUNDAY (2)
2.73	2.90
2.74	2.91
2.75 EDIT BAND SATURDAY (2)	2.92 EDIT BAND SUNDAY (3)
2.76	2.93
2.77	2.94
2.78 EDIT BAND SATURDAY (3)	2.95 EDIT BAND SUNDAY (4)
2.79	2.96
2.80	2.97
2.81 EDIT BAND SATURDAY (4)	

3 ALTERNATION

3.1 ALTERNATION PERIOD

4 BACKWASH

4.1 FILTER WASH FREQUENCY	4.4 RINSE DURATION
4.2 NUMBER OF PUMPS FOR FILTER WASHING	4.5 DIRTY FILTER WARNING PRESSURE
4.3 FILTER WASH DURATION	

5 MANUAL

6 DISPLAY

6.1 MODULE TEMPERATURE	6.7 DIGITAL INPUT 2
6.0 ANALOGUE SIGNAL	6.8 RELAY 1 OUTPUT
6.3 VOLTAGE HOURS	6.9 RELAY 2 OUTPUT
6.4 HOURS WORKED	6.10 SOFTWARE VERSION
6.5 NUMBER OF START-UPS	6.11 POWER CONSUMED BY PUMP
6.6 DIGITAL INPUT 1	6.12 POWER CONSUMED BY NETWORK

7 LOG

9 SETUP MENU (DIAGRAM)

8 ENTRADAS SALIDAS

8.1 DIGITAL INPUT 1

8.4 INPUT 2 FREQUENCY

8.2 INPUT 1 FREQUENCY

8.5 RELAY 1 OUTPUT

8.3 DIGITAL INPUT 1

8.6 RELAY 2 OUTPUT

9 ADVANCED PARAMETERS

9.1 UNITS OF PRESSURE

9.7 PRIMING TIME

9.2 FULL-SCALE VALUE TRANSDUCER

9.8 PARAMETER LOCK

9.3 SWITCHING FREQUENCY

9.9 RESET ALARMS

9.4 NOMINAL FREQUENCY MOTOR

9.10 RESET NUMBER OF START-UPS

9.5 LOW WATER LEVEL ALARM ACTIVE

9.11 FACTORY SETTINGS

9.6 CONSUMPTION LIMIT OF LOW WATER ALARM

10 SETUP MENU

1 PARAMETERS						
Par	Description	Units	VALUES			Notes
			Default	Min.	Max.	
1.1	Language		Español	--	--	To define the language used to interact with the variator
1.2	Set time					To adjust the date and time of the variator
1.3	Motor current	A	5	2	11	Indicate the consumption in amperes AT 400V found on the motor specifications plate.
1.4	Number of pumps per cycle		1	1	8	Indicate the number of pumps involved in the filtration cycles.
1.5	Maximum filter pressure	bar	4	2	7,3	Indicate the maximum pressure the filter can withstand, found on its specifications plate.
1.6	Rotation direction		si	si	no	Modify the motor rotation direction, if it is rotating anticlockwise.

2 CYCLES						
Par	Description	Units	VALUES			Notes
			Default	Min.	Max.	
2.1	Number of bands monday		00:00	0	4	The number of times the swimming pool water must be recirculated per day (Monday)
2.2			24:00			Sets the start time of band 1
2.3	Edit band monday* (1)		50			Sets the end time of band 1
2.4		Hz	00:00			Sets the rotational frequency of band 1
2.5			24:00			Sets the start time of band 2
2.6	Edit band monday (2)		50			Sets the end time of band 2
2.7		Hz	00:00			Sets the rotational frequency of band 2
2.8			24:00			Sets the start time of band 3
2.9	Edit band monday (3)		50			Sets the end time of band 3
2.10		Hz	00:00			Sets the rotational frequency of band 3
2.11			24:00			Sets the start time of band 4
2.12	Edit band monday (4)		50			Sets the end time of band 4
2.13		Hz				Sets the rotational frequency of band 4
2.14	Copy day monday to tuesday**					Enables you to copy the previous time settings to the next day (Tuesday).
			00:00			
2.86			24:00			Sets the start time of band 1
2.87	Edit band sunday (1)		50			Sets the end time of band 1
2.88		Hz	50			Sets the rotational frequency of band 1

10 SETUP MENU

2 CICLOS

Par	Description	Units	VALUES			Notes
			Default	Min.	Max.	
2.89			00:00			Sets the start time of band 2
2.90	Edit band sunday (2)		24:00			Sets the end time of band 2
2.91		Hz	50			Sets the rotational frequency of band 2
2.92			00:00			Sets the start time of band 3
2.93	Edit band sunday (3)		24:00			Sets the end time of band 3
2.94		Hz	50			Sets the rotational frequency of band 3
2.95			00:00			Sets the start time of band 4
2.96	Edit band sunday (4)		24:00			Sets the end time of band 4
2.97			50			Sets the rotational frequency of band 4

* There is a complete configuration for every day of the week. This manual only explains how to configure Monday and Sunday, as a summary, but the process is the same for the other days of the week.

** When the day's settings are complete, it allows you to copy this configuration directly to the following day, saving time when setting every day individually.

3 ALTERNATION

Par	Description	Units	VALUES			Notes
			Default	Min.	Max.	
3.1	Alternation period		1	1	14	In systems with more than 1 pump, you can set how often (in days) to alternate the pump in operation. N.B.: The alternation, as it is in days, is done from 00:00. If a pump is running, it will not stop to alternate. The alternation in this case will be applied when the filtration cycle ends.

4 BACK WASH

Par	Description	Units	VALUES			Notes
			Default	Min.	Max.	
4.1	Filter wash frequency	Hz	50			Sets the frequency of the pump(s) of operation for the filter cleaning process
4.2	Number of pumps for washing		1	1	8	Regardless of the number of pumps involved in the filtration, you can set the number of pumps that you wish to use to clean the filter.
4.3	Filter	min	5	1	60	Operating time of the pumps involved in cleaning the filter

10 SETUP MENU

4 BACK WASH

Par	Description	Units	VALUES			Notes
			Default	Min.	Max.	
4.4	Rinse duration	min	1	1	60	Once the filter is clean, the operating time of the pumps for rinse the remaining dirty water from the filter
4.5	Dirty filter warning pressure	Bar	1,5	1	Torque 1.5 or 4 bar	Pressure from which a warning will appear on the screen requiring the filter to be cleaned (for this function it is necessary to install a pressure transducer)

5 MANUAL

5	.		M	A	N	U	A	L													
			0	.	0	H	z		(0	s)									
			0	.	0	B	a	r													
E	x	i	t																	O	N

The objective of this screen is to test the pump operation, at a specific frequency, for a controlled time, to correctly select the operating frequency of the cycles in section 2 of the settings menu. Press F2 to activate the pump initially for 2 minutes at the maximum frequency of the pump. Each time you press the F2 key increases the operating time on a scale of 2 minutes, 15 minutes, 30 minutes, 1 hour, 2 hours, 4 hours or 8 hours. At any time, by pressing the F1 key, you can stop the pump operation. Every time you press the keys (▲) or (▼) you increase or decrease, respectively, the frequency of the pump operation by a tenth of a Hz.

6 DISPLAY

Par	Description	Units	VALUES			Notes
			Default	Min.	Max.	
6.1	Module temperature	°C				Shows the current temperature of the power module. If the temperature is very high, the speed variator itself will limit the speed of the pump to prevent the electronics of the speed variator being damaged.
6.2	Analogue signal	mA		4	20	Shows the value of the pressure transducer reading in mA
6.3	Voltage hours	Hours				Indicates the hours the pump has been connected to the electricity grid regardless of whether it has been running or not.
6.4	Hours worked	Hours				Indicates the hours of pump operation.
6.5	Number of start-ups					Indicates the number of times that the pump has been started up.
6.6	Digital input 1					Indicates whether input 1 is enabled or not; if it is enabled, the reason for this.

10 SETUP MENU

6 DISPLAY

Par	Description	Units	VALUES			Notes
			Default	Min.	Max.	
6.7	Digital input 2					Indicates whether input 2 is enabled or not; if it is enabled, the reason for this.
6.8	Relay 1 output					Indicates whether relay 1 is enabled or not; if it is enabled, the reason for this.
6.9	Relay 2 output					Indicates whether relay 2 is enabled or not; if it is enabled, the reason for this.
6.10	Software version					Indicates the version of the software of the control panel (screen) and the power panel (aluminium radiator).
6.11	Power consumed by pump	W				Indicates the instantaneous power consumed by the pump.
6.12	Power consumed by network	W				Indicates the instantaneous power consumed by all the pumps that are operating at that time.

7 LOG

Shows a log of anomalies of the pump where the speed variator is connected, indicating the date, the time and the anomaly that occurred. This information is very important for detecting possible anomalies in the functioning of the installation.

8 INPUTS OUTPUTS

Par	Description	Units	VALUES			Notes
			Default	Min.	Max.	
8.1	Digital input 1	Unused				Unused / Emergency stop / Forced start An input can be enabled to carry out a remote stop or to force the pump to start, even though it is out of reach of a filtration cycle. Important: Input 1 is a normally open input, therefore to enable it the contact must be closed <u>without voltage</u>.
8.2	Input 1 frequency	Hz	50	10	50	If digital input 1 is activated for forced operation, you can indicate the frequency at which you want the pump to function when the input is enabled.
8.3	Digital input 2	Unused				Unused / Emergency stop / Forced start A second input can be enabled to carry out a remote stop or to force the pump to start, even though it is beyond the scope of a filtration cycle. Important: Input 2 is a normally open input, therefore to enable it the contact must be closed <u>without voltage</u>.
8.4	Input 2 frequency	Hz	50	10	50	If digital input 2 is activated for forced operation, you can indicate the frequency at which you want the pump to function when the input is enabled.

10 SETUP MENU

8 INPUTS OUTPUTS

8.5 Relay 1 output	OFF	OFF / On / Alarm	You can programme relay 1 to be enabled when the pump starts up or also when an alarm is triggered in the installation. N.B. Output 1, when enabled, acts as a closed contact without voltage.
8.6 Relay 2 output	OFF	OFF / On / Alarm	You can programme relay 2 to be enabled when the pump starts up or also when an alarm is triggered in the installation. N.B. Output 2, when enabled, acts as a closed contact without voltage.

ENGLISH

9 ADVANCED PARAMETERS

Par	Description	Units	VALUES			Notes
			Default	Min.	Max.	
9.1	Units of pressure		Bar	Bar	PSI	You can modify the units to represent the pressure of the installation.
9.2	Full-scale value transducer	Bar	10	5	25	Enables you to adjust the range of detection of the transducer if its scale is not the standard 4-20 mA (0-10 Bar)
9.3	Switching frequency	KHz	7,7	2,5	16	Enables you to modify the switching frequency of the variator, reducing the noise, although uncommon, of the switching at the expense of an increase in temperature of the electronics. N.B. We do not recommend modifying the default value except when expressly indicated by the Technical Department.
9.4	Nominal frequency motor	Hz	50	50	60	Modifies the maximum frequency of pump operation.
9.5	Low water level alarm active		YES	YES	NO	Enables the constant monitoring of the pump running dry, if this occurs.
9.6	Low water alarm limit	%	75	50	90	Value used in the mathematical algorithm that calculates the pump running dry.
9.7	Priming time	min	2	1	10	During the priming time, the detection of running dry will not be operative even though the monitoring is enabled.
9.8	Parameter locking		NO	NO	YES	Enables you to lock the settings of the variator and the pump so they are not modified after start-up.
9.9	Reset alarms		NO	NO	YES	Enables you to reset all the alarms triggered to date. N.B.: We do not recommend this reset because you would lose very important information that could help solve possible problems in the installation.

10 SETUP MENU

9 ADVANCED PARAMETERS

Par	Description	Units	VALUES			Notes
			Default	Min.	Max.	
9.10	Reset number of start-ups		NO	NO	YES	Enables you to set the pump start-ups counter to 0.
9.11	Factory settings		NO	NO	YES	This parameter will remove all the settings entered in the configuration of the variator, returning it to its initial status, as it was when installed for the first time.

11 WARNINGS/ALARMS

MESSAGE	REASONS	SOLUTION(S)
PRESSURE WARNING: FILTER CLEANING	Indicates that the pressure entered in the parameter 4.5 (DIRTY FILTER WARNING PRESSURE) has been exceeded.	Press the button BACK WASH and perform the steps indicated by the filter cleaning wizard, as the system detects a high pressure in the filter, probably due to excess soiling.
ALARM F01 OVERCURRENT	Indicates excessive consumption in the motor.	Check that the pump rotates freely with no obstructions.
ALARM F02 SHORT CIRCUIT	The motor is communicated or has burnt out. Not all wires have been connected. Internal fault in the variator.	Disconnect the motor from the variator and check that the message disappears. If this is not the case, contact your nearest technical service. Check that all the cables of the motor are correctly connected to the motor itself and to the variator. Also supervise the correct wiring of the frequency converter's power supply. Contact your nearest technical service.
ALARM F03 EXCESS TEMPERATURE OF THE MODULE	The power module has reached a very high temperature, compromising its reliability.	Ensure the ambient temperature does not exceed the extremes set out in this manual. Ensure the variator is properly ventilated; in this case check that the pump has a fan and that the fan cover has been installed.
ALARM F04 INPUT VOLTAGE	The variator is not receiving electric current, or is outside of the upper and lower limits.	The electrical supply to the variator has been interrupted. The electrical connection cable from the mains electricity to the variator has been disconnected.
ALARM F06 MOTOR FAULT	The motor is communicated/disconnected. Loss of synchronism	Check that the cables to the motor are properly connected, as the variator is not detecting the motor, or it is burnt out. There may also be a loss of synchronism of the motor during operation due to a significant, quick change in the pumping conditions.
ALARM F07 LOW WATER LEVEL	The variator detects that the pump is working without water in the body of the pump.	Ensure the pump aspirates the fluid correctly.
ALARM F08 MAXIMUM PRESSURE LIMIT	The variator detects that the filter is very soiled or at a pressure close to bursting.	Check the filter does not need cleaning and that the impulsion valves allow recirculation.
ALARM X13 INTERNAL ERROR	There is no communication between the control panel (cover), and the power plate (radiator). Internal fault in the variator.	Check that the flat cable that communicates both electronic circuits are well connected and tightened. There may be one-off read error of the firmware. We recommend cutting the power to the variator for a few minutes. If, when the power is reconnected to the variator, the message remains, contact your nearest technical service.

12 WARRANTY

THE GUARANTEE OF THE VARIATOR IS 24 MONTHS FROM THE DATE OF PURCHASE: THE USE OF NON-ORIGINAL SPARE PARTS, ALTERATIONS OR IMPROPER USE SHALL RENDER THE PRODUCT WARRANTY VOID.

ENGLISH

13 DISPOSAL AND ENVIRONMENTAL ASPECTS

To dispose of the parts that comprise the variator, you must abide by the current regulations and laws of the country where the product is used. In any case, do not dispose of polluting parts into the environment.

14 DECLARATION OF CONFORMITY

Bombas Saci, S.A., CL/ Can Cabanyes 50-58, Pol. Ind. Circuit de Catalunya, 08403, Granollers (Spain) declares, under its full responsibility, that the product to which this manual refers complies with the following European Directives and national action provisions:

- Directive 2004/108/CE about electromagnetic compatibility (EMC)
- Directive 2006/95/CE about low voltage
- Directive 2002/96/CE and 2003/108/CE about hazardous substances (RAEE)
- Directive 2002/95/CE about hazardous substances (ROHS)
- Basic EC regulation EN 55011 (EMC)
- Basic EC regulation EN 61000-6-2 (EMC)
- Basic EC regulation EN 61000-6-1 (EMC)
- Basic EC regulation EN 62477-1 (Safety)

Managing Director



David Ferré Ferrer

CERTIFICADO DE PRUEBAS, TEST CERTIFICATE,
CERTIFICAT D'ESSAIS, CERTIFICATO, PRÜFURKUNDE,
CERTIFICADO DE ENSAIO, TEST CERTIFIKÁT, TEST
BELGESI, מבחן תעודת

