

ASIN AQUA Salt NET

CLF, REDOX

2025, VS Pump – FW 8.09





Basic safety instructions

This user manual contains essential safety instructions, as well as information on the installation, commissioning, and maintenance of the device. It must be read by all individuals involved with the device—especially those responsible for its installation, commissioning, maintenance, and operation. Please read the manual carefully and follow all instructions. To minimize the risk of injury, this product must not be used by children. Failure to follow the safety instructions may pose a risk to people, the environment, and the device itself. Non-compliance with these instructions will void any claims for damages.

Inadequate operator qualification

Improper handling of the device can result in serious injury and damage to property.

- The system operator must ensure that all personnel maintain the required level of qualification.
- All work must be carried out by appropriately qualified personnel.
- Insufficiently qualified persons must be prevented from accessing the system, e.g. by means of access codes and passwords.

Overdose of chemicals

Despite the comprehensive safety features of ASIN AQUA Salt NET, probe failure or other errors may lead to chemical overdoses. This can result in serious injury and property damage.

- Install the device in such a way that uncontrolled chemical dosing cannot occur, and so that any such dosing can be detected in time to prevent damage.
- Uncontrolled dosing of chemicals can cause injury and property damage. Although the device is equipped with multiple safety features, a chemical overdose cannot be completely ruled out in the event of a failure of the measuring probes or the device itself. Install the device in a way that prevents uncontrolled chemical dosing and ensures that any such dosing is detected in time to prevent damage. Chemicals must be used in quantities that do not result in dangerous concentrations, even in the case of an overdose. Avoid using chemicals in excessively large containers or at excessively high concentrations.

Formation of chlorine gas when dosing chemicals into standing water

If the control flow meter becomes blocked or malfunctions, there is a risk of dosing chemicals into standing water. In such a case, the combination of chlorine disinfectant and pH reducer can produce toxic chlorine gas. Chemical agents must never be dosed into standing water.

Failure to understand safety instructions and information

Failure to follow safety instructions due to misunderstanding may result in serious injury or damage to property.

- Read the entire user manual carefully.
- Do not handle the device if you are unable to eliminate all potential risks arising from a lack of understanding of the safety instructions and other information.

Use of new device features

Due to continuous development, the ASIN AQUA Salt NET device may contain features that are not fully described in this version of the user manual. Using these new or extended features without full understanding by the operator may result in damage to the device and other serious consequences, including injury and damage to property.

- Before using a function, make sure you fully understand it, including all related conditions.
- Check for an updated version of the user manual or supplementary documentation for the relevant functions:
<http://manuals.asekool.com>
- Use the integrated help function on the device to obtain detailed information about the functions and their settings.
- If you cannot understand the function in depth and safely based on the available documentation, do not use this function.

Overdose at incorrect pH value

If disinfection is activated before the pH value has stabilized within the optimum range of 7.0 to 7.4, a severe overdose of chlorine or bromine may occur. This can result in serious injury and damage to property.

- **Do not start chlorine disinfection until the pH value is stable within the optimal range of 7.0 to 7.4.**

Before using the device

Make sure you have the latest and updated version of the user manual and other documentation for all functions of the device. Use and read the integrated help functions. If you do not understand the information about certain functions of the device, do not use these functions.

Handling chemicals for pool water treatment

Chemicals used in ASIN AQUA Salt NET must be handled safely to prevent damage or injury. Aseko recommends that you always use personal protective equipment when handling pH and chlorine products. See the Material Safety Data Sheet (MSDS).



Important notes for proper functioning.

WARNING:

Never mix pH and chlorine agents During maintenance, always rinse the hoses and valves with clean water to prevent mixing.

Never use hydrochloric acid (HCl, hydrochloric acid). HCl is volatile. The use of HCl-based chemicals will damage the equipment.

Never install the device in unventilated technical shafts with high humidity, as this can seriously damage electronic components, especially the display. Damage caused by high humidity will not be recognized as a warranty defect. If the ASIN AQUA Salt NET device is located in an environment with high humidity and low temperature (e.g., a garden shed), leave it ON at all times. This helps maintain a higher internal temperature and significantly reduces humidity inside the unit. The same applies when storing the unit in winter.

The installation must be protected by a residual current device (RCD).

CLF probe calibration: Calibration can only be performed if the pH is stable within the range **6.8–7.5**. After replacing the electrolyte, wait at least **1 hour**, but ideally **24 hours**, for the signal to stabilize before continuing with calibration.

Never use cyanuric acid stabilizers in the ASIN AQUA Salt NET device. Cyanuric acid forms a chlorine-cyanurate complex, which rapidly reduces the disinfecting ability of chlorine and prevents the probe from measuring free chlorine. Please note that some chlorine tablets contain cyanuric acid. Make sure that there is no cyanuric acid in your pool.

The pool must be properly grounded and all metal parts bonded in accordance with applicable standards to ensure user safety and correct system operation.

ASIN AQUA Salt NET

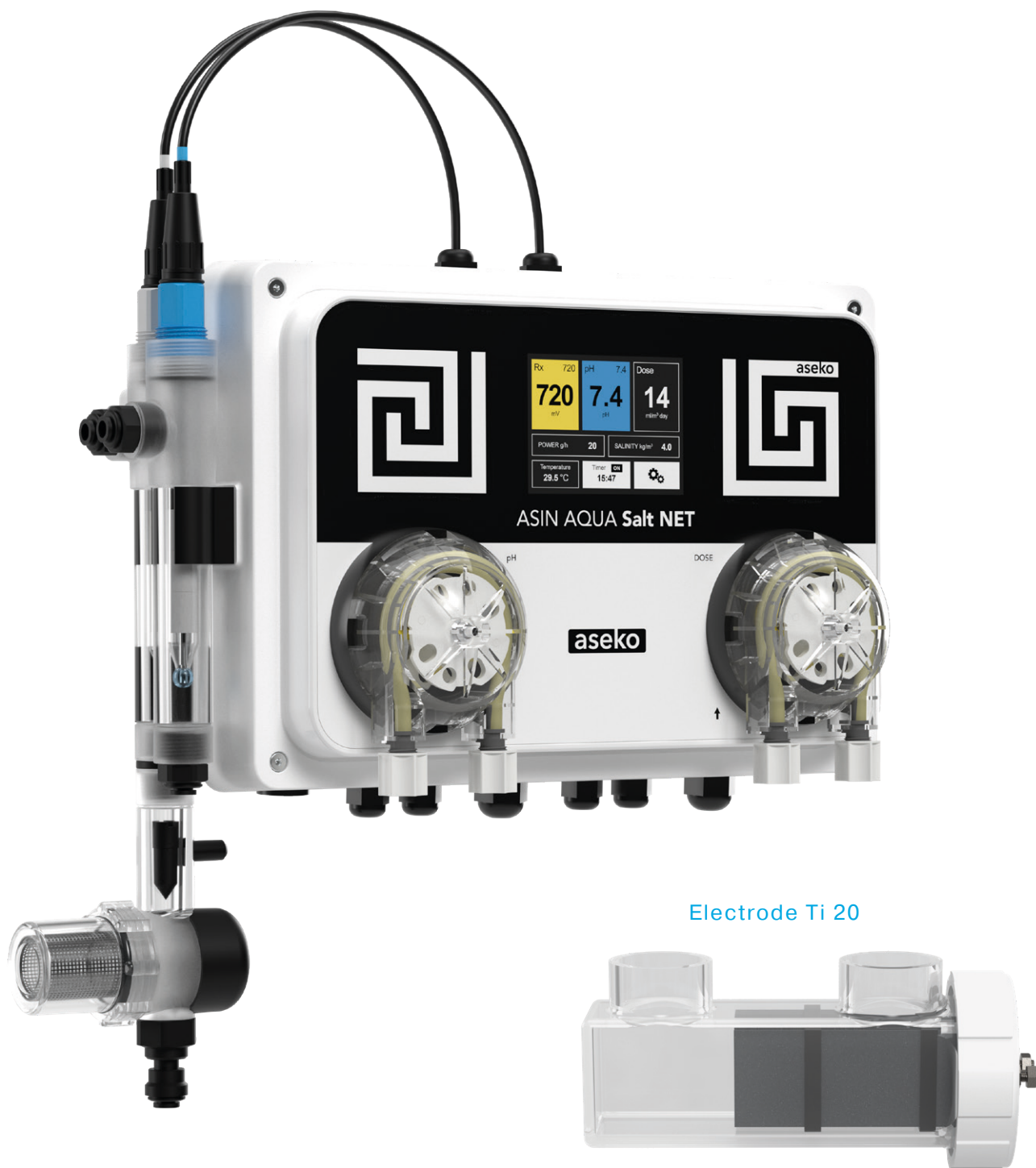

ASIN AQUA **Salt NET** CLF

134521

ASIN AQUA **Salt NET** Redox

134522

**RECOMMENDED
MAXIMUM POOL
VOLUME**

**REDOX & CLF
70 m³**

ASIN AQUA Salt NET

Compact device designed for salt water. Highly accurate pH and disinfection measurement thanks to Aseko probes. Stable disinfection control is ensured by controlled salt water electrolysis. The new Ti 20 titanium-iridium electrode produces up to 20 g of chlorine per hour at a salt concentration of 4 g/l. An integrated peristaltic pump ensures automatic pH control, while second pump allows the dosing of flocculant, algicide, or ACO stabilizer. An option of controlling the circulation pump according to a set time interval. An internet connection allows remote monitoring via a web platform or mobile app. Suitable for pools and whirlpools up to 70 m³.

Water treatment

Electrode Ti 20

The innovative power supply technology and an improved Ti 20 electrode surface boost the production up to 20 g of chlorine per hour at a salt concentration of 4 g/l.

Chlorine regulation

Accurate measurement by the ASEKO CLF probe or by Redox probe for salt in combination with the control electrolysis algorithm maintain the required value of disinfection. Option to boost chlorine levels with Hybrid function.

pH control and dosing

Accurate measuring by pH probe long-life in combination with the dosing algorithm assures the required water quality.

Use of hydrochloric acid is strictly forbidden.

Daily dosing of algicide or stabilizer

A daily dose of algicide or stabilizer ensures perfect water quality in all conditions. Use Aseko ALGICID during periods of higher humidity, or Aseko ACO Stabilizer in intense sunlight and high temperatures.



What you will find in the box

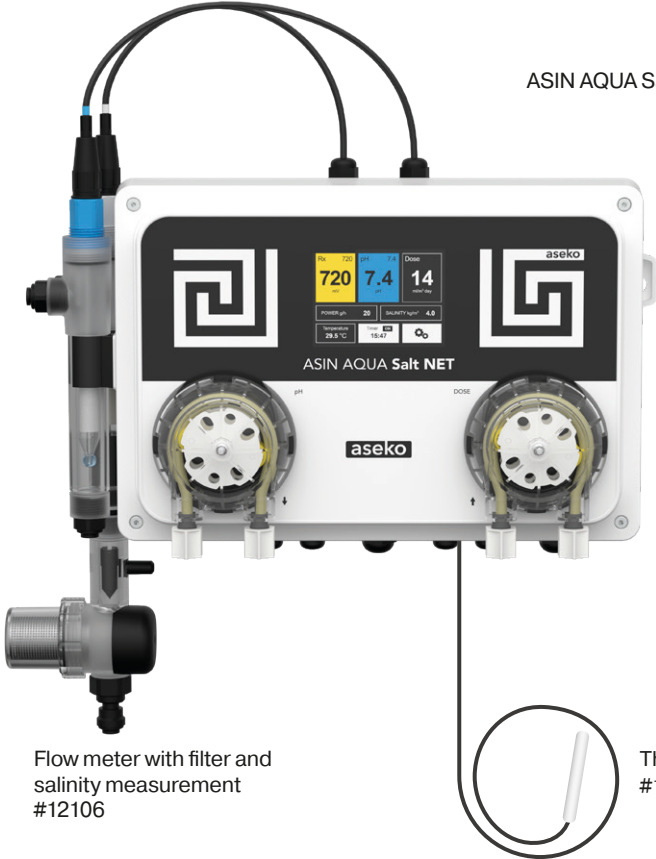

ASIN AQUA Salt Net

Long Life pH Probe # 12012



CLF Probe #12052



Peristaltic pumps #12093

or

Redox Probe for Salt #12113



Flow meter with filter and salinity measurement #12106



Thermometer #13192

Measuring water valve 2 pcs #12006



Injection valve 2 pcs #12005



Cap with suction tube housing 2 pcs #13415



Thermometer sump #12044



Connecting pipe - 1/4" (6.35 mm) #13277



Dowels and screws #12125



Electrode Ti 20 #12203



Accessories available for purchase

External touchscreen display
#12048

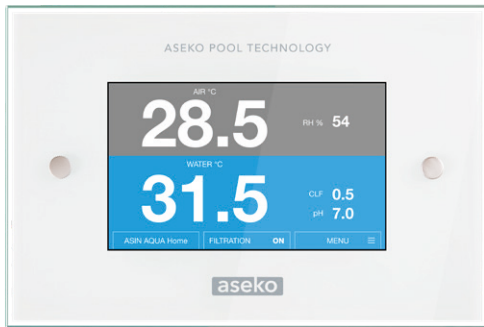

Injection manifold 4x 1/4"
#13395



Inserting plug DN50 with 1/4" (6.35 mm) thread
#12134



EXT Salt NET
#13290



pH 7.00 Buffer #12065
Redox Buffer #12063



Digital Photometer Aseko
#13449



ASEKO original chemical solution

20 l or 5 l volume

pH MINUS #12130 or pH PLUS #12120



ALGICID #12156



Volume 10 kg

SALT PURE 10kg #13344



BALANCER #13345



MAGNESIUM #13039



Bottle 1 kg

SUPER CHLOR #13120



ASIN AQUA Salt NET installation

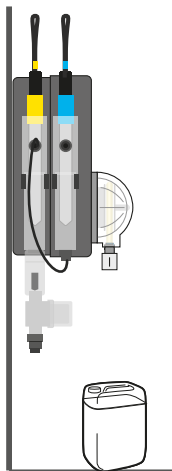
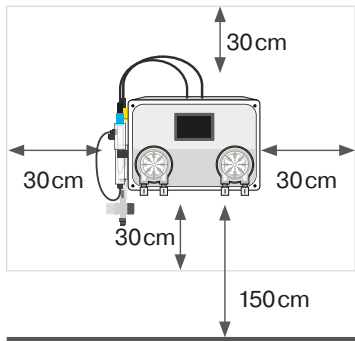
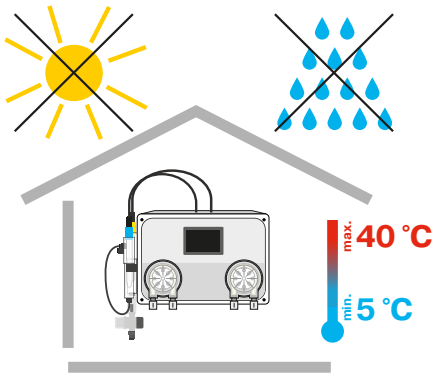

ASIN AQUA Salt NET should be installed on a wall in a dry and dust-free environment with a temperature not falling below +5 °C and not exceeding +40 °C. The location should be chosen so that there is at least 30 cm of free space on all sides and the height above the floor is max. 150 cm. Use the screws supplied with ASIN AQUA Salt NET for mounting. Dimensions of ASIN AQUA Salt NET approx. **28 x 20 x 12 cm**.

WARNING

The temperature at the installation site should be consistently between **+5 and +40 °C**. Humidity max **70% RH**.

Direct sunlight, high humidity, and dust can damage the ASIN AQUA Salt NET.

WARNING

Never install the unit in unventilated technical shafts with high humidity, as this can seriously damage the electronic components, especially the display. Damage caused by high humidity will not be recognized as a warranty claim. If the ASIN AQUA Salt NET is in an environment with high humidity and low temperature (e.g., a garden shed), leave it permanently ON. This helps maintain a higher internal temperature and significantly reduces humidity inside the unit. The same **applies when storing the unit in winter.**

Maximum distance between injection valves from ASIN AQUA peristaltic pumps must not be greater than **8 m**.

The vertical distance between ASIN AQUA and the bottom of the tanks must not exceed **2 m**.

The device must be mounted **vertically on the wall** and positioned above the upper edge of the chemical canisters.

POOL WATER

The ASIN AQUA must be installed in **freshly filled water** treated with an **INORGANIC** superchlorinating agent (**SUPERCHLOR #13120**).

Do not use organic chlorine!

Ensure that the water in the pool is chemically clean and **DOES NOT CONTAIN CYANURIC ACID**, or impurities!

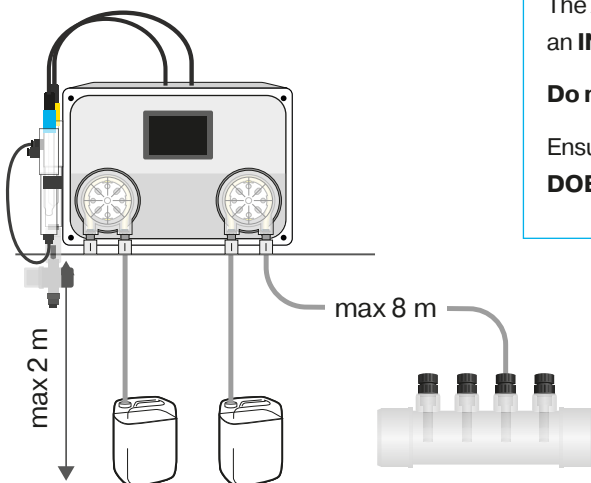

Installing the Probes

Probe wrench
#13046



1. Carefully insert the pH, CLF or REDOX probe into the housing.
2. Hand tighten or use the plastic wrench socket for probes.
3. Connect the CLF or Redox probe with yellow marked cable and pH probe with blue marked cable.

After probes have been inserted, slightly tightened and connectors have been connected, ASIN AQUA Salt NET is ready for connection to the water system of your pool.

WARNING: Only hand tighten the probes or use the plastic wrench socket for probes. Do not use pliers or steel wrench.

WARNING

Tighten the probes only by hand or with the plastic key provided. Do not use pliers or other tools!

CLF Probe
#12052



Redox Probe for
Salt
#12113

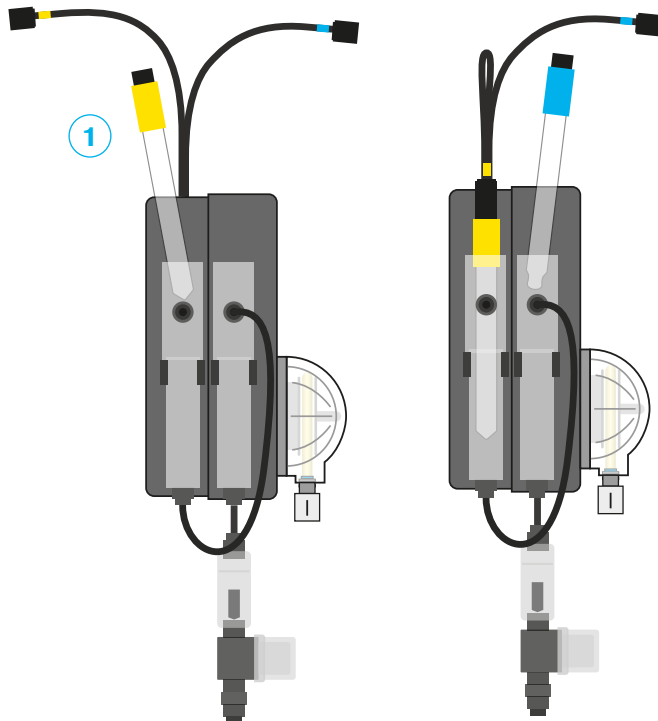

pH Probe Long
Life #12012



Connection of electrode Ti 20

Electronic flowdetector with filter and salinity sensor

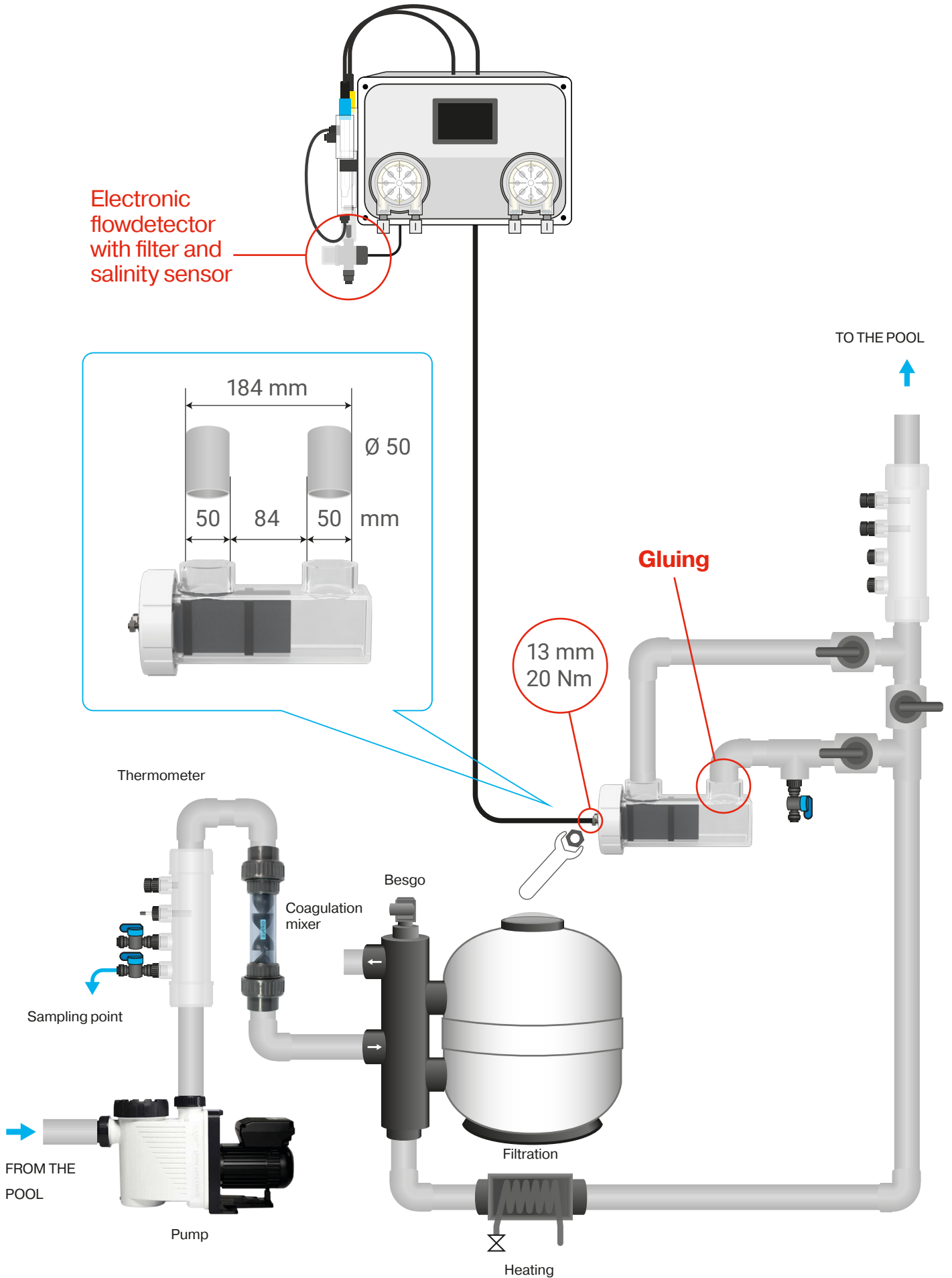
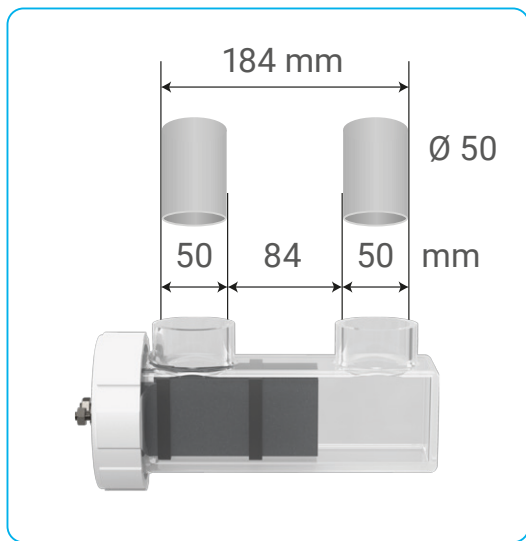

Thermometer

Gluing

13 mm
20 Nm

TO THE POOL

Sampling point

Besgo

Coagulation mixer

Filtration

Heating

FROM THE POOL

Pump

Connecting of Ti 20 electrode

Electrode Ti 20

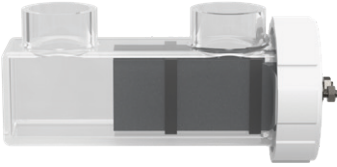

One of the main components of the ASIN AQUA Salt NET device is the titanium electrode Ti2 0 with a ruthenium–iridium coating, which provides electrolysis of pool water and generates chlorine. Install the electrode into a bypass of the filtration circuit according to the diagram on the following page.

To create the bypass, use plastic piping with an external diameter of 50 mm fitted with ball valves at both ends, allowing the bypass to be closed for maintenance or electrode replacement. Insert a ball valve between the inlet and outlet pipes of the bypass to enable circulation in case the electrode is shut down and the bypass is closed.

Glue the electrode on the opposite side of the pipe, opposite the ball valves. Do not use fast-drying adhesives. Suitable products for bonding are Griffon UNI-100 or Griffon UNI-100 XT.

Once the bypass is connected to the system, you can connect the electrode's power cables coming from the ASIN AQUA Salt NET control unit.

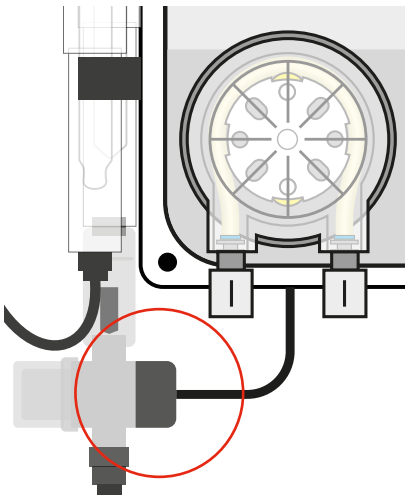

Salinity measuring unit

Salinity measurement

The sensor for measuring salt content is part of the measuring water filter assembly.

Connection of measured water

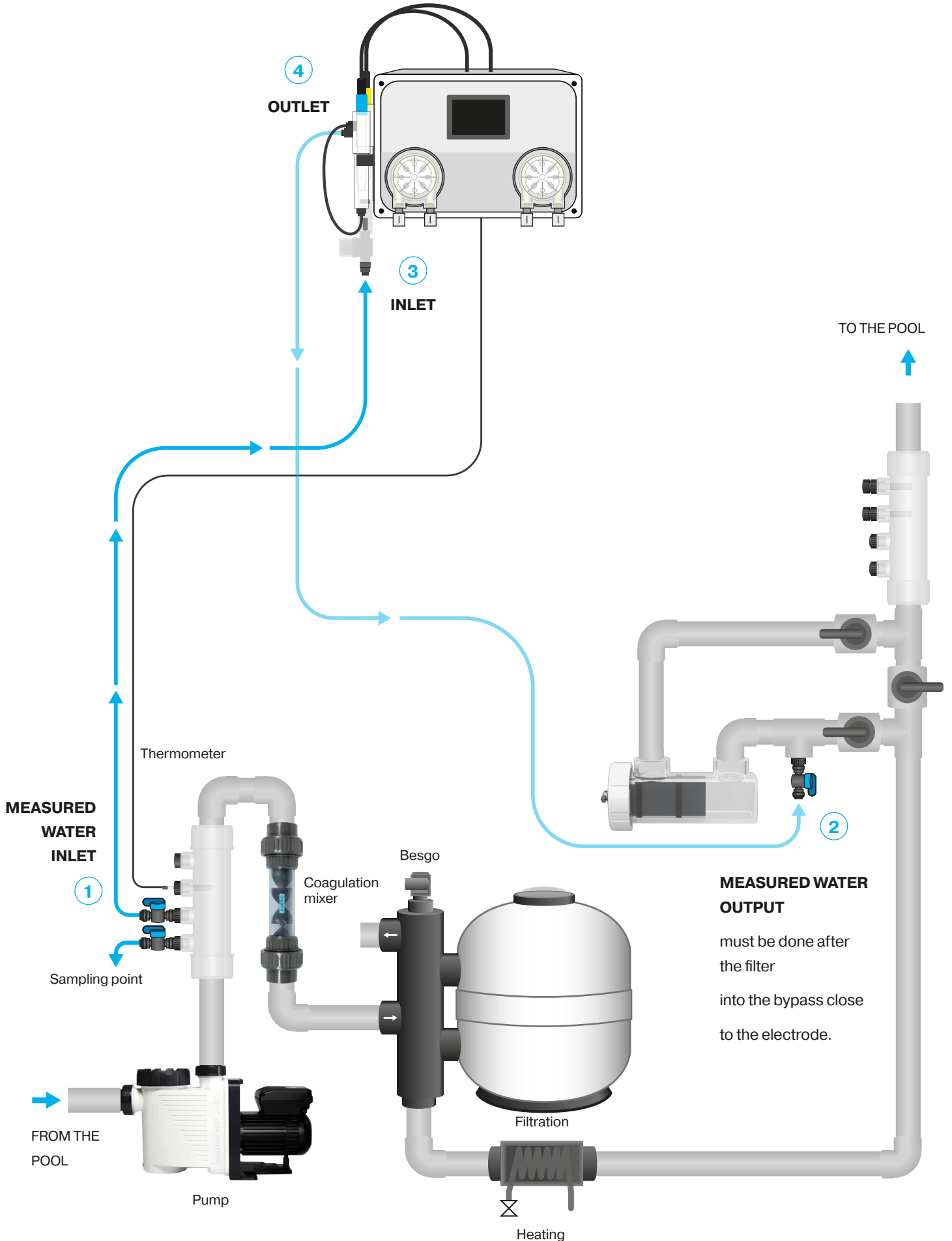

Connection of measured water

Screw the **measuring water valve** in the injection manifold 4x 1/4" or into the glue head #12134. **Tighten the measuring water valve by hands only. Do not use pliers or other tools.**

- 1 **CONNECT THE MEASURED WATER INLET** to the pipe **after the pump and before the filter** and the coagulation mixer.
- 2 **CONNECT THE MEASURED WATER OUTLET** to the pipe **after filtration and heating** or to the overflow tank or skimmer.

To connect the measured water to your ASIN AQUA, use the 1/4" (6.35 mm) #12008 connecting pipe, which is included in the delivery.

WARNING

To ensure tight connections, cut the pipe at a 90° angle. Use special pliers #13325 to cut plastic pipes. The cut must be clean and smooth. Do not use ordinary scissors or knives!

The measured water can be easily connected to the ASIN AQUA using **Speedfit** fittings.

CONNECTION, push the connecting pipe into the **Speedfit** connector and then secure by pulling on the hose.

DISCONNECTION press and hold the circular clamp **Speedfit** and pull out the connecting pipe.

- 3 **INLET** of the measured water into the ASIN AQUA using the connecting pipe to the Speedfit fitting on the measuring water filter.
- 4 **OUTLET** connect the measured water from ASIN AQUA to the Speedfit fitting on the probe well using the connecting pipe.

After connecting and opening the water supply, your ASIN AQUA is ready to measure the disinfection content and pH value in your pool so that it complies with hygiene limits.

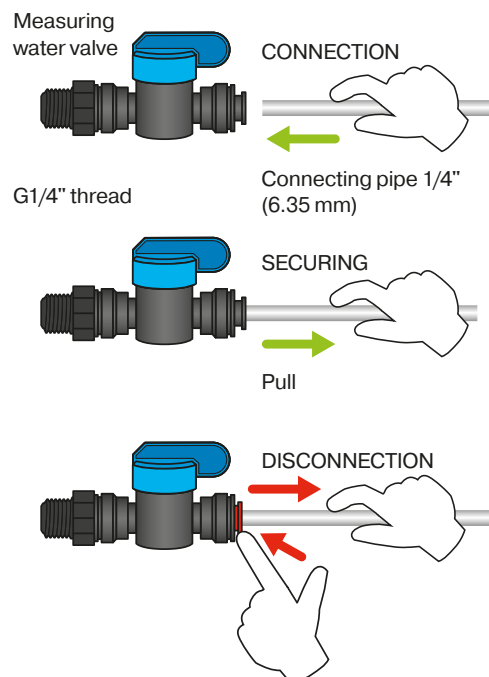
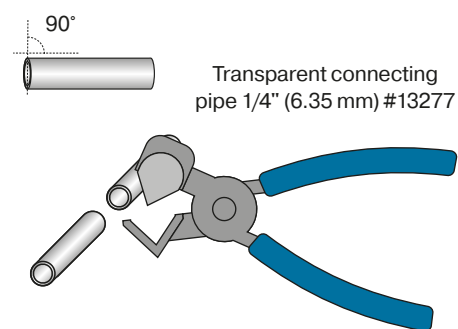
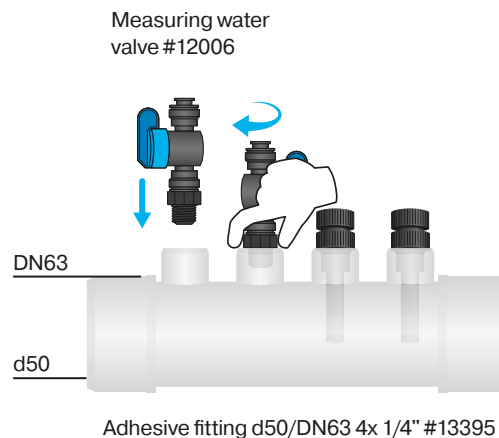

Connection for pool chemicals

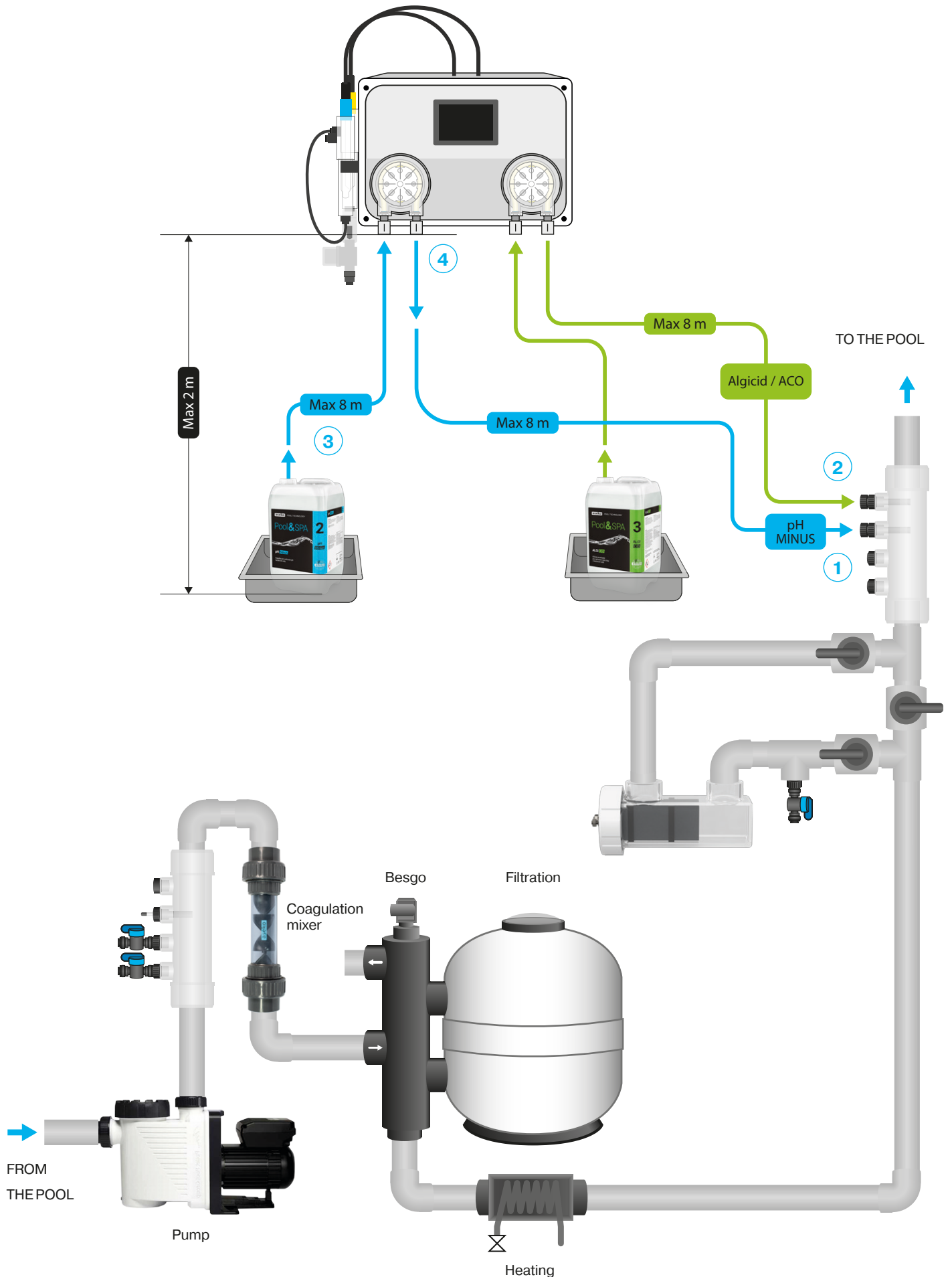

Connection for pool chemicals

Screw the **injection valve** in the injection manifold 4x 1/4" or into the glue head #13134. **Tighten the measuring water valve by hands only. Do not use pliers or other tools.**

- 1 **INJECTION VALVE pH** connect to the pipe after filtration and discharge of the measured water.
- 2 **INJECTION VALVE Algicide** connect to the pipe after filtration and discharge of the measured water.

To connect the dosing agents to your ASIN AQUA, use the 1/4" (6.35 mm) connecting pipe #12008, which is included in the delivery.

WARNING

To ensure tight connections, cut the pipe at a 90° angle. Use special pliers #13325 to cut plastic pipes. The cut must be clean and smooth. Do not use ordinary scissors or knives!

- 3 **CANISTER CONNECTION** Use the 20 l Canister Suction Kit #13415. Thread the connecting pipe through the suction cap so that it ends directly above the bottom of the container.
- 4 **PUMP CONNECTION** Connect the pump suction on the left to the canister, and the pump discharge on the right to the injection valve.
- 5 **CONNECTING THE INJECTION VALVES** Pull the pipe through the nut, thread the pipe onto the injection valve and tighten the nut firmly by hand.

WARNING

NEVER connect pH minus agent to the disinfection pump or disinfectant to the pH pump! In the event of a cross connection, an error message will appear after ten doses of ASIN AQUA. Correct the pipe installation and then you can continue operating your ASIN AQUA.

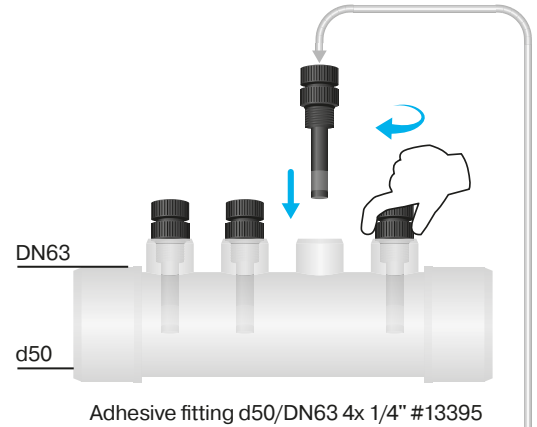

Adhesive fitting d50/DN63 4x 1/4" #13395

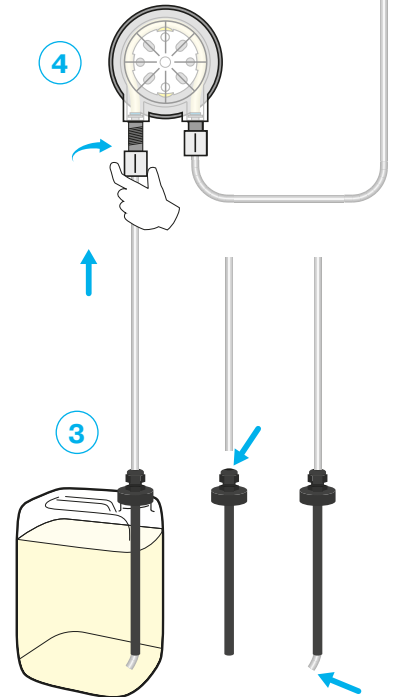

Suction kit for 20 l canister #13415

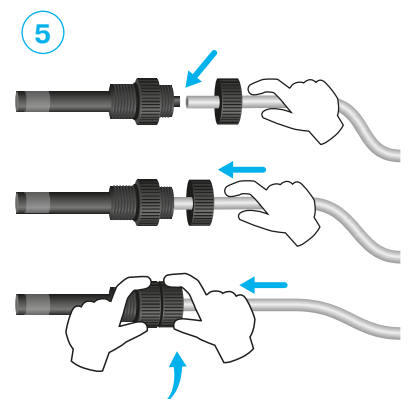

Connecting the filtration pump

ASIN Aqua Salt Net provides filtration control via a potential-free output and supports control of variable-speed (VS) pump.

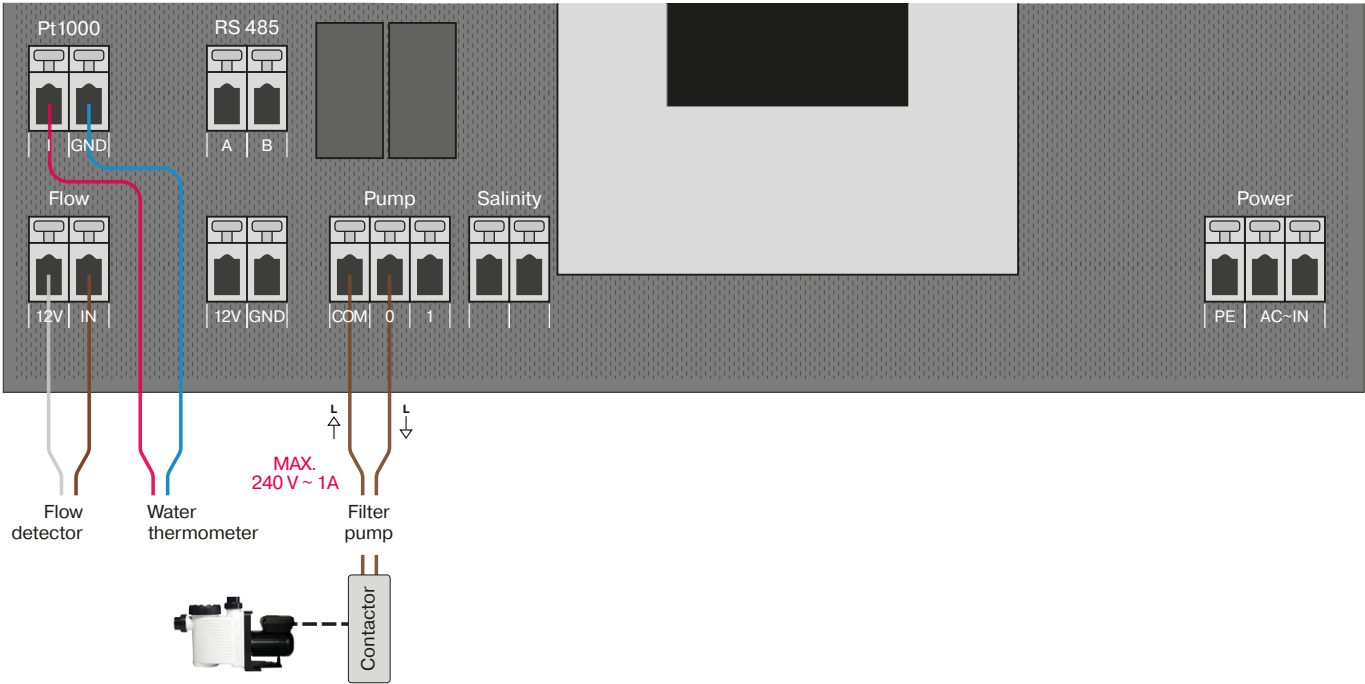

VS Pump connection

Connect variable-speed pumps according to the manual.

The controlled speeds are:

- 1 – Low (or STOP)
- 2 – Medium.

VS filtration pump
Pentair, Dab, Speck – newer types

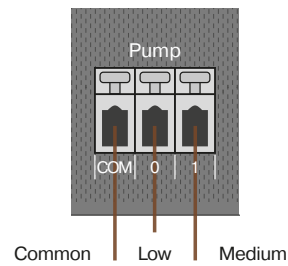

VS filtration pump
Aquagem

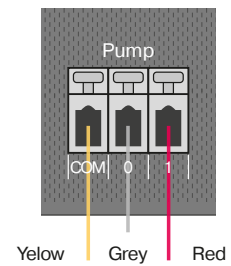



Electrical connection

Connecting the device to the mains:

Connect the 230 VAC $\pm 10\%$ / 50 Hz power cable to a power outlet.

The mains socket must be protected by a 30 mA residual current device!

After switching on, the display lights up and the ASIN AQUA Salt NET start screen appears during startup.

Disconnecting the device from the mains:

Disconnect the ASIN AQUA Salt NET power cord from the 230 VAC $\pm 10\%$ / 50 Hz power outlet.

WARNING

If the device is used in a manner not specified by the manufacturer, the protection provided by the device may be compromised.

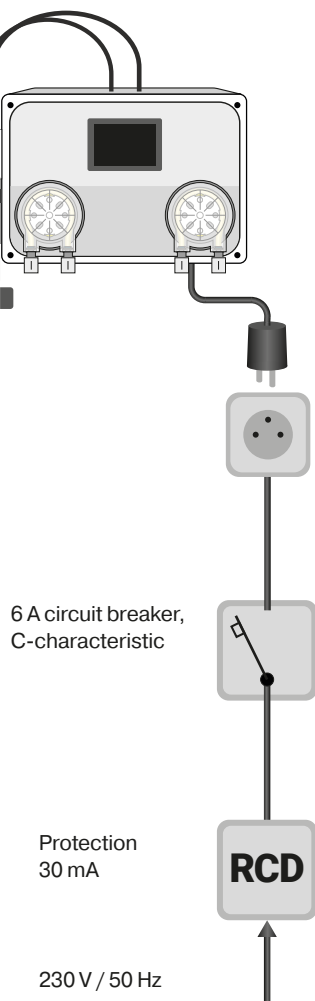

Power supply	230 VAC $\pm 10\%$ / 50 Hz
Power consumption	150 W
Fuses	T100 mA
Overvoltage category	II
Protection	IP40
Climate resistance	+5 to +40°C / RH 70%
Degree of contamination	2
Max. altitude	max 2,000 m above sea level
Weight	2,2 kg
Location	Wall
Controlled values	Free chlorine or Redox, pH
Pump power	60 ml/min. / max 1 bar
Measured water pressure	max 1.5 bar

The device is intended for indoor use

MAX POOL VOLUME

70 m³

Max. Salt
4.5 kg/m³

Min. Salt
3 kg/m³

System start-up

Salting the pool water

Chlorine generating depends on the salt concentration and water temperature. The lower the temperature, the lower the chlorine production. You can boost the electrolyzer by increasing the salt concentration. 1 kg of salt per cubic meter of water can increase the electrolysis power for about 20 %. Maximum salt concentration is 4 kg/m³.

Exceeding the recommended salt concentration will overload power supply components of the ASIN AQUA Salt NET. The main unit is protected by maximum current control circuit. Overload automatically disconnect the power supply. Lower the salt concentration before switching the power supply again. Never use lower salt concentration than 1,5 g/l - this expressively reduce the electrode lifetime. Higher salt concentration is very corrosive and may cause corrosion of pool equipment.

Disinfection is expressively affected by following:

- temperature
- intensity of sun shining
- quantity of person using the pool
- weather conditions
- organic pollution

Instructions to operate the electrolyzer:

The amount of chlorine produced depends only on the concentration of salt in the pool water.

Never switch on the ASIN AQUA Salt NET before the salt in the water is completely dissolved.

Electrode connection to ASIN AQUA Salt NET must be done only when disconnected power supply.

Important water parameters

Parameter	Recommended value	Impact on water quality
pH	7,2 - 7,4	Affects the effectiveness of disinfection
Alkalinity	80 - 120 mg/l	Stabilizes pH
Salt content	3 - 4.5 g/l	Affects electrode performance
Water hardness	max. 350 ppm	Causes electrode clogging
iron and manganese content	max. 0,1 mg/l	Causes a brown-green discoloration of the water
Cyanuric acid	0ppm	Cyanuric acid greatly diminish the effectiveness of chlorine, making it impossible to measure and control.

SALT

BIOCID CERTIFIED

Salt to be used

Do not use rock or sea salt. All additives may cause electrode lifetime shortening.

ASIN AQUA Salt NET is designed to electrolyze water with 4 kg/m³ salt concentration.

Electrode may be damaged at lower salt concentrations than 1,5 kg/m³. It is necessary to provide routine salt concentration control. The salt concentration changes only little during electrolysis. The main change in salt concentration is caused by filter backwashing, splashing and strong rains.

Following table displays salt quantity in kg necessary to increase the concentration to 4 kg/m³.

SALT CONTENT kg/m ³	POOL VOLUME									
	10 m ³	15 m ³	20 m ³	25 m ³	30 m ³	35 m ³	40 m ³	50 m ³	60 m ³	70 m ³
	Salt quantity in kg, necessary to increase the concentration to 4 kg/m ³									
0	40	60	80	100	120	140	160	200	240	280
0,25	37,5	56,25	75	93,75	112,5	131,25	150	187,5	225	262,5
0,5	35	52,5	70	87,5	105	122,5	140	175	210	245
0,75	32,5	48,75	65	81,25	97,5	113,75	130	162,5	195	227,5
1	30	45	60	75	90	105	120	150	180	210
1,25	27,5	41,25	55	68,75	82,5	96,25	110	137,5	165	192,5
1,5	25	37,5	50	62,5	75	87,5	100	125	150	175
1,75	22,5	33,75	45	56,25	67,5	78,75	90	112,5	135	157,5
2	20	30	40	50	60	70	80	100	120	140
2,25	17,5	26,25	35	43,75	52,5	61,25	70	87,5	105	122,5
2,5	15	22,5	30	37,5	45	52,5	60	75	90	105
2,75	12,5	18,75	25	31,25	37,5	43,75	50	62,5	75	87,5
3	10	15	20	25	30	35	40	50	60	70
3,25	7,5	11,25	15	18,75	22,5	26,25	30	37,5	45	52,5
3,5	5	7,5	10	12,5	15	17,5	20	25	30	35
3,75	2,5	3,75	5	6,25	7,5	8,75	10	12,5	15	17,5
4	0	0	0	0	0	0	0	0	0	0

Installation test

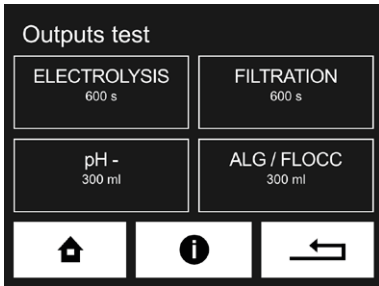

Before starting operation, test the installation of ASIN AQUA Salt NET
Most problems are caused by incorrect installation.

Test procedure

On the main screen, select the button with the settings symbol.
On the next screen, select "DOSING TEST".

Start both pumps one after the other and check all connections of the connecting pipes for leaks while they are running. Check the injection valves to ensure that they are not blocked and that no air bubbles are forming in the pipes.

WARNING

Any obstructions, bubbles, or leaks in the connecting pipe will prevent the ASIN AQUA Salt NET from functioning properly! Clear plastic pipes allow you to monitor the flow of fluid into the injection valves.

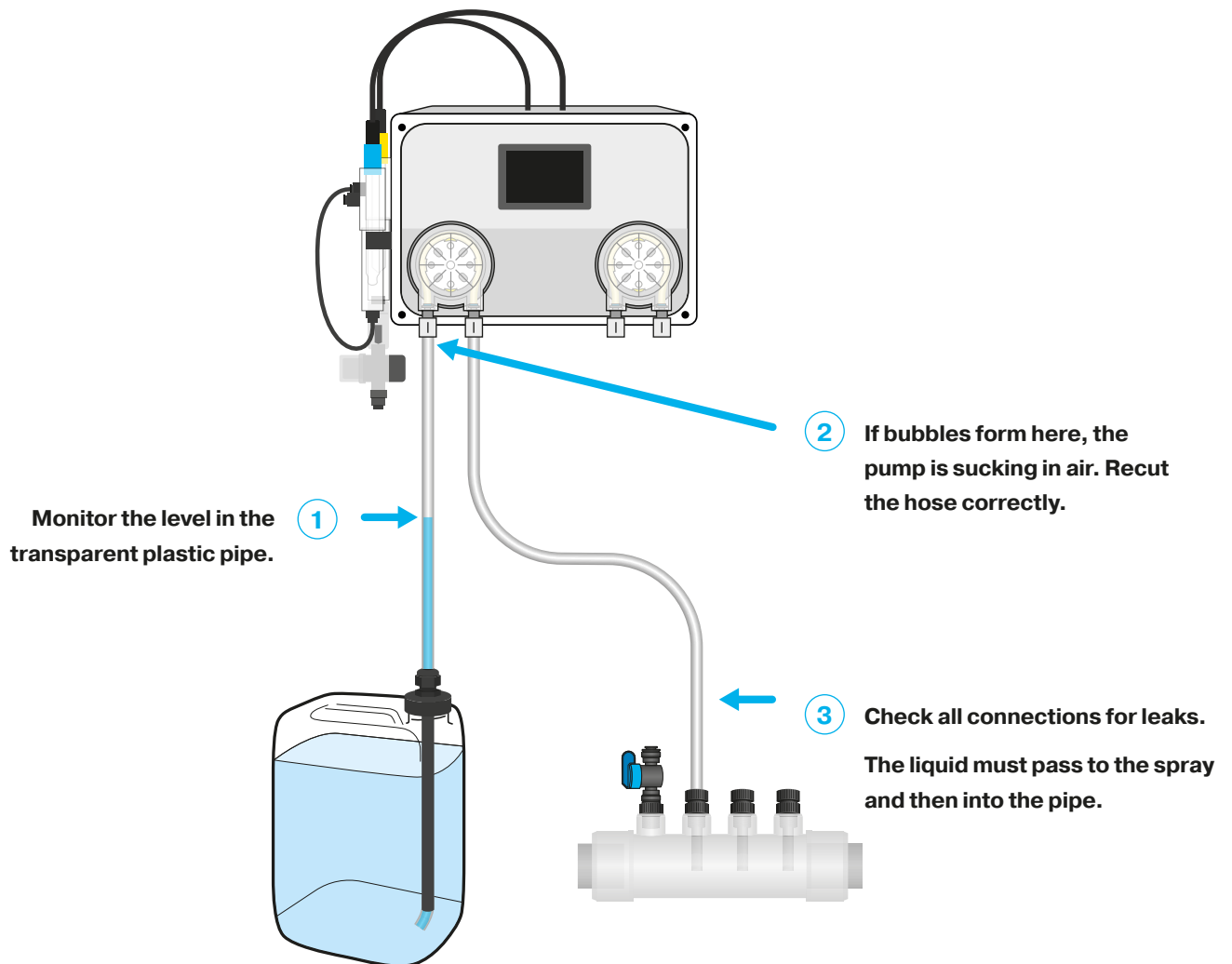

Control principles

Home screen

Displays the measured required values and status information.

For example, clicking on the Chlorine field takes you to the settings for the required chlorine value in the pool water.

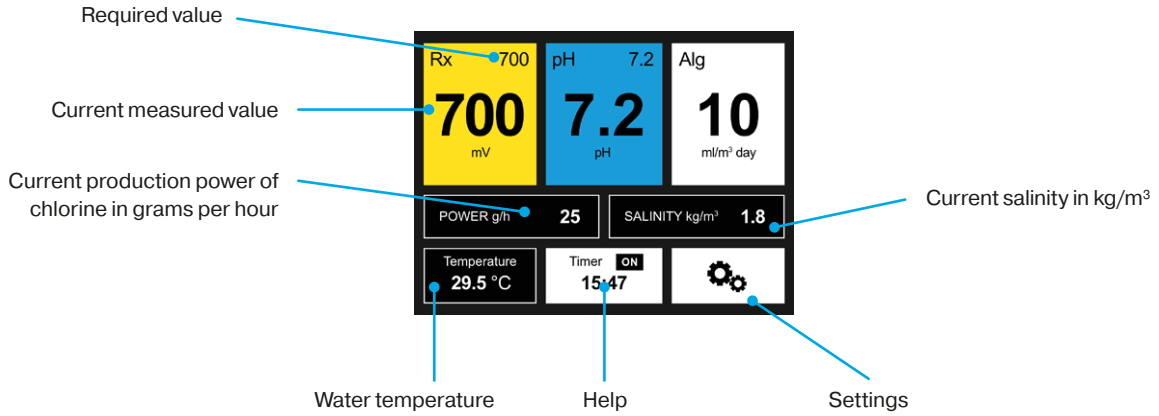

Settings

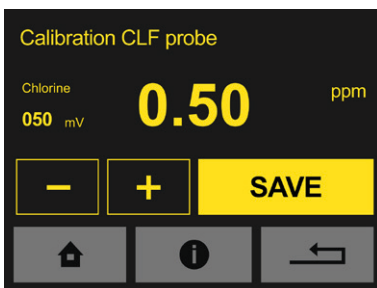
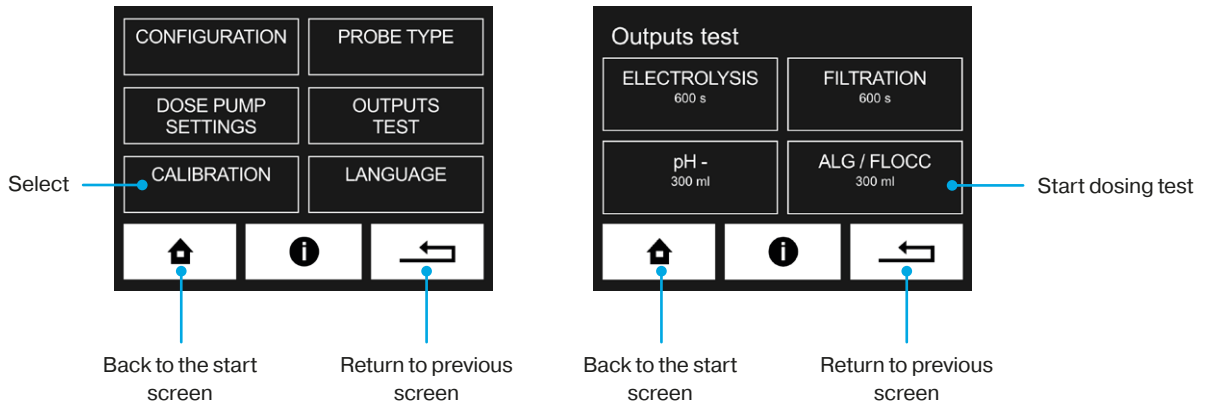

Decreases the value



Increase value



Save value

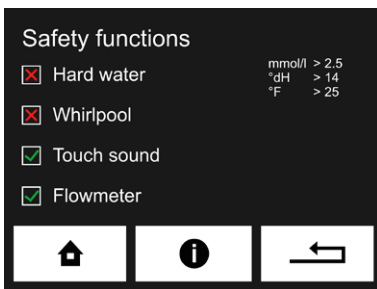
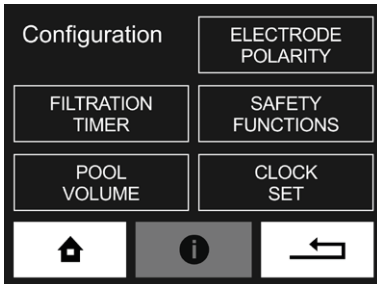
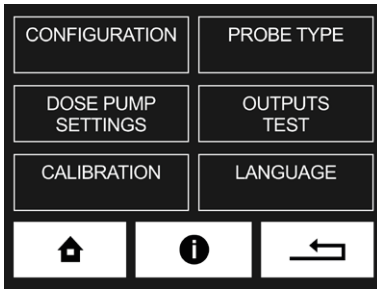

WARNING
Only switch off the flow meter in the event of a malfunction!



Settings

Configuration – pool volume, clocks, filtration timer, polarity, pool type, water hardness, **Dose pump settings** – dosing of algicide / flocculant **Calibration** – pH probe, CLF probe, Rx probe, thermometer, salinity **Probe selection** – selection of disinfection probe, **Output test** – testing pumps and manual dosing, filtration and electrolyzer

Pool parameter settings

Every pool is unique. Temperature, size, location, and water hardness all affect how ASIN AQUA controls and fine-tunes your pool water. To ensure optimal performance, you must set the characteristics and values of your pool in ASIN AQUA.

Pool volume

For ASIN AQUA to work properly, you need to set the pool volume correctly. Calculate the volume of your pool: Length (L) times width (W) times depth (D) equals pool volume (V) – (L × W × D = V). Use the + and – buttons to adjust the value.

Pool type

Select your pool type by checking the appropriate boxes (pool whirlpool).

Hard water

Set the water hardness in your pool in degrees dH, 0-9 is soft, 9-21 is hard and 21+ is very hard.

Flow meter

The flow monitor detects the water flow to the probes. Chemicals will only be dispensed if flow to the probes is detected. Therefore, flush the flow meter strainer regularly.

Disinfection probe selection

- Free chlorine probe CLF



- RX redox potential probe



- Time based electrolysis minutes of electrolysis per hour (no probe)

Commissioning and setting the required values

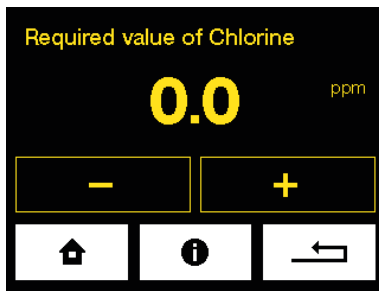

Commissioning procedure

The water in the pool must be clean and free of impurities. Ideally, it should be freshly filled from the mains water supply.

- Turn the filtration system to run NONSTOP for 24 hours
- If you have a CLF probe, set the required value to 0.0 mg/l. If you have a REDOX probe, set the required value to 000 mV. If you are using time-based electrolysis, set the value to 0 min/hour

CLOSED



Close the water supply to the probes

ASIN AQUA will display the warning "No flow to probes".

Perform superchlorination

Shock chlorinate the pool water with Super CHLOR (inorganic active chlorine without stabilizers). Follow the instructions on the package (1 kg = 80 m³).

Before opening the water supply to the probes

Before opening water supply to the probes, pool water must be **clean water** and **chlorine concentration** measured by a photometer or Pool Tester must be within the range **0.3 to 1.2 mg/l**. If it is **lower concentration** repeat shock chlorination. If **higher concentration** wait for the chlorine in the water to decrease.

OPEN



Open the water supply to the probes

The "No flow to probes" warning will disappear from the ASIN AQUA display.

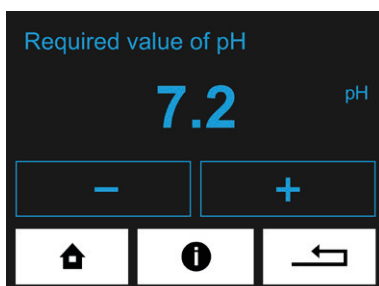

pH setting

Since the ASIN AQUA water treatment system is effective over a wide pH range, it is advisable to set the desired pH value to the same level as the water you are adding, or slightly lower.

Required pH value = pH of the water being added (in the range 7.0 to 7.4)

The pH may change during operation, but if it is within the range of 7.0 to 7.4, it is not necessary to change the setting

If you have a CLF probe

The following conditions must be met for the CLF probe to function properly:

pH of pool water

The ideal pH of pool water should be 7.2.

The pH value of the pool water must be stable.

If the pH value fluctuates, the chlorine value in the pool water also changes.

Chlorine content mg/l	Water temperature
0,3 – 0,5	24 – 26 °C
0,5 – 0,8	26 – 32 °C
0,8 - 1	Higher than 32 °C

WARNING

Before proceeding to setting of the required values, or after replacing the electrolyte, keep the probe connected to the water for at least 1 hour, ideal 24 hours, to stabilize its measurement.

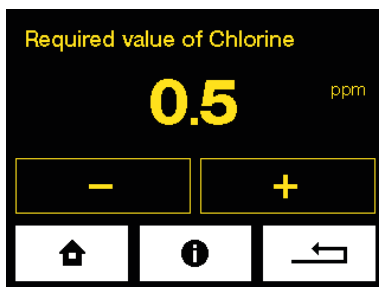

Required chlorine value

The table shows the recommended chlorine levels in pool water. The required chlorine content varies with the temperature of your pool water and should never be lower than 0.3 mg/l.

Procedure for setting the required chlorine value

Use a photometer to measure the chlorine value in a sample of the pool water.

If the required chlorine concentration in the pool water (measured with a photometer) is:

- **EQUAL** to the value on the ASIN AQUA display, your device is ready to maintain the chlorine in the pool.
- **LOWER** than the value on the ASIN AQUA display, increase the required value by 0.1 to 0.2 mg/l (regardless of the required value according to the table) compared to the current disinfection setting.

After mixing the pool and stabilizing the value on the ASIN AQUA display, repeat the measurement.

Repeat the procedure until the chlorine concentration in the pool water corresponds to the displayed value or is slightly higher, then set the correct required value according to the table. You can then calibrate the CLF probe (see the Calibration of the CLF probe section).

- **HIGHER** than the desired value on the ASIN AQUA display, you can calibrate the CLF probe (see the Calibrating the CLF probe section).

WARNING:

Resolve low chlorine levels in the pool water by increasing the required disinfection value.

RECOMMENDATION:

Check the chlorine content of the pool water once a week using a photometer or tester.

If you have a Redox probe

For the REDOX probe to work properly, the following conditions must be met:

pH of pool water

The ideal pH of pool water is 7.2

The pH value of the pool water must be stable.

If the pH value fluctuates, the Redox value in the pool water also changes.

Chlorine content mg/l	Water temperature
0,3 – 0,5	24 – 26 °C
0,5 – 0,8	26 – 32 °C
0,8 - 1	Higher than 32 °C

WARNING

Before proceeding to setting of the required values, keep the probe connected to the water for at least 1 hour, ideal 24 hours, to stabilize its measurement.

Required chlorine value

The table shows the recommended chlorine levels in pool water. The required chlorine content varies with the temperature of your pool water and should never be lower than 0.3 mg/l.

Procedure for setting the desired Redox value

Set the desired REDOX value to 650 mV.

Use the tester to check that the chlorine content in the pool water is between 0.5 and 1.2 mg/l.

Wait 24 hours for the probe to stabilize.

Fine-tuning

Use a photometer to measure the chlorine value in a sample of pool water.

- If the chlorine value in the pool water is **IN DESIRED RANGE**, your ASIN AQUA is ready to maintain the desired chlorine concentration in the pool water.
- If the chlorine value in the pool water is **LOW**, increase the the desired REDOX mV value in the menu.
- If the chlorine value in the pool water is **HIGH**, decrease the the desired REDOX mV value in the menu.

Every 10 mV corresponds to approximately 0.1 mg/l of chlorine in the pool water.

EXAMPLE:

The chlorine value in the pool water is 0.3 mg/l, the value shown on the display is 650 mV. If you want to have a chlorine value of 0.5 mg/l, you must increase the set redox value by 20 mV to 670 mV.

NOTE:

The relationship between the redox potential and the chlorine content in the pool water cannot be determined using a precise table. The correct redox value must be determined by repeated photometric measurements.

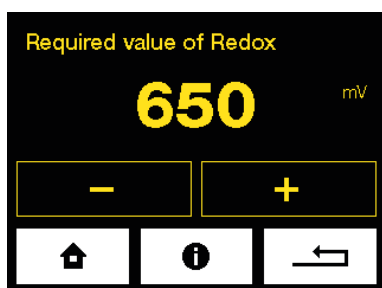

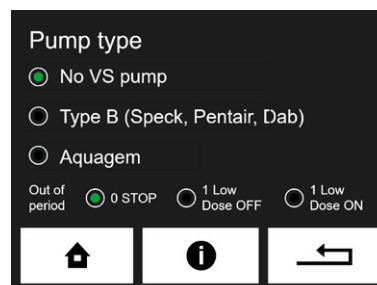
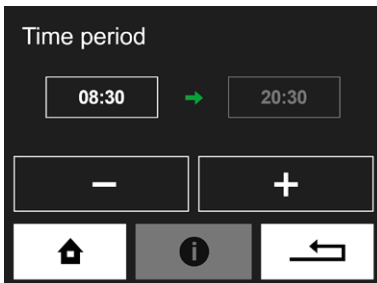
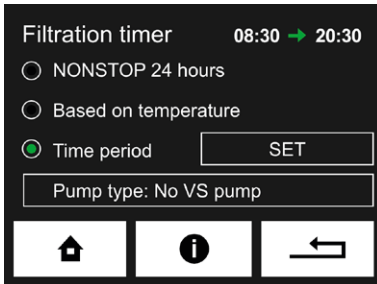
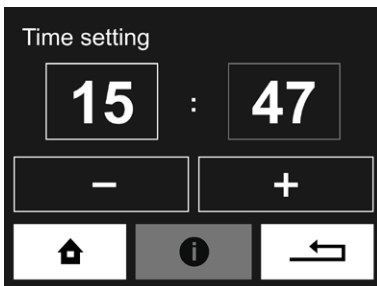
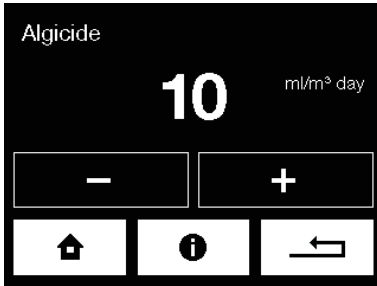
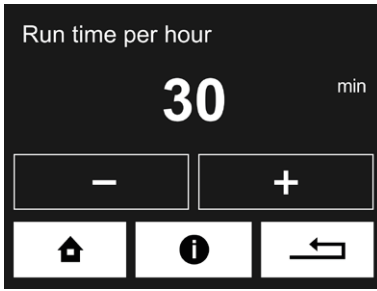

If using a time-based production without a probe

In situations where a probe is not used or temporarily out of service, the system allows chlorine generation to be managed by time control.

Set the desired operating duration - the number of minutes per hour for the electrolysis. This ensures continuous pool water disinfection in the temporary absence of disinfection probe.

Dose pump settings

Flexible dosing of Algicide or ACO chlorine stabilizer to ensure ideal water quality in any environment.

Use Algicide in humid climates prone to algae growth, and ACO for uncovered pools exposed to sunlight and higher water temperatures.

A typical dosage of Algicide is 10 ml per m³ per day, which can be temporarily increased if algae appear.

A typical dosage of ACO is 3 ml per m³ per day.

Setting the filtration timer

1. Set the current time
2. Set the pump type (default settings – No VS pump)
3. Select one of three types of filtration control
 - **NONSTOP 24h** - Filtration will run NONSTOP
 - **According to temperature** - ASIN AQUA Salt NET calculates the optimal filtration running time based on the morning water temperature. The filtration pump switches on every day at 6:00 a.m. The optimal filtration run is then calculated based on the measured water temperature (water temperature /2 +2; at a water temperature of 26 degrees, filtration will run from 6:00 to 21:00)
 - **Period** - Set your own filtration interval. With VS pump you can choose between 3 options outside of period time.

0 STOP - filtration pump is stopped.

1 Low Dose OFF - filtration speed is on speed one. Dosing is OFF.

1 low Dose ON - filtration is on speed one. Dosing is ON

Choose the type of your pump according to connection of filtration pump chapter

Operational measurement and calibration

The pH probe can be calibrated within a pH range of 6.2 to 7.8.

The pH probe cannot be calibrated if the **LOW** or **HIGH** warning (low or high probe signal) is displayed.

pH probe calibration

When pH is being measured in operation, there may be a difference between the value measured by ASIN AQUA and the actual pH value in water. Proceed to the calibration.

pH probe calibration menu

Non-calibrated value

The pH probe calibration menu always displays the original non-calibrated value. Calibration of the pH probe is not possible when the new value differs by more than 1 from the non-calibrated value. If the difference from the non-calibrated value exceeds 1, the probe should be sent for inspection or replaced with a new one.

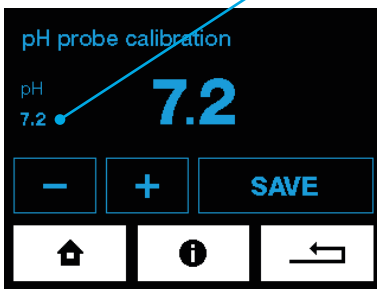

pH probe calibration process

Calibration can be done in two ways:

1. With a buffer

- **Close the water supply to the probes.**
- Remove the probe from ASIN AQUA Salt NET : rinse the probe with clean water and wipe it.
- The probe must remain connected to the device via the cable. Dip the probe in the calibration buffer and after the value displayed on ASIN AQUA is stable, enter the buffer value into the pH Probe Calibration menu.

pH - Buffer 7.00 #12065



2. With a colorimeter or Pool Tester

- **The water supply to the probes must be open**
- Measure the pH value directly in pool water using a colorimeter or Pool Tester.
- Then enter this value into the pH Probe Calibration menu. Calibration can be performed in the range of 6.4-7.8.



Digital Photometer Aseko #13449

Calibrating the CLF probe

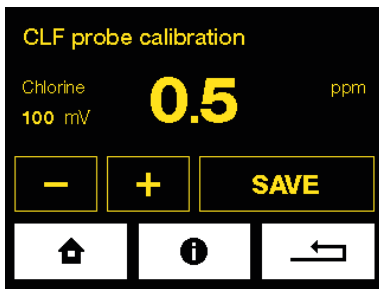

Do not calibrate the probe until the pool water is thoroughly mixed and the value displayed on the ASIN AQUA Aqua Salt NET is stable. After adding fresh electrolyte, it takes at least 4 hours for the signal to stabilize.

Perform calibration of the CLF probe when the manually measured value of free chlorine is equal to or higher than the value you want to have in your pool.



Digital Photometer
Aseko # 13449

Calibration is performed by entering the manually measured value of chlorine concentration (using a photometer) in the CLF probe calibration menu.

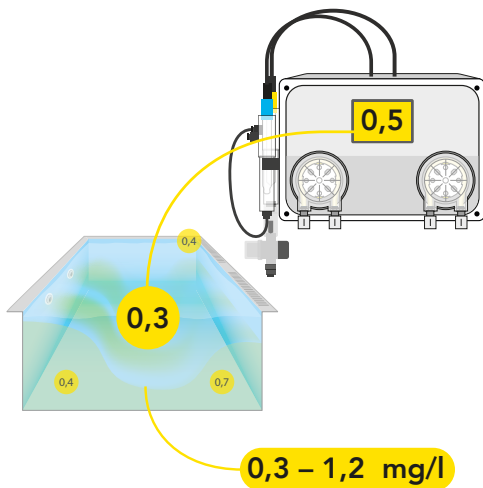

Calibration **is not necessary** if the difference between the photometer measured value and the value shown on the display **is less than 0.2 mg/l**.

Calibration is best performed with chlorine concentrations in the pool water in the range of **0.3 - 1.2 mg/l**.

Calibration limitations

The CLF probe cannot be calibrated if **the** output signal is less than 20 mV.

The CLF probe can only be calibrated in the CL range **from 0.3 to 5.0 mg/l**.



Redox probe calibration

Use a buffer

- **Close the water supply to the probes.**
- Remove the probe from ASIN AQUA Salt NET:
rinse the probe with clean water and wipe it with a paper towel.
- The probe must remain connected to the device via the cable during the calibration. Dip the probe in the calibration buffer and after the value displayed on ASIN AQUA Salt NET is stable, enter the buffer value into the Redox probe calibration menu.

RECOMMENDATION: Perform the calibration using the 650 mV buffer. If the non-calibrated value differs by 50 mV from the buffer, it indicates that the probe is faulty.

Salinity calibration

If salt concentration in the water is different from concentration shown by ASIN AQUA Salt NET, calibrate the salinity in the Salinity calibration menu.

Warning: Salinity calibration is not possible if the water thermometer is not connected.

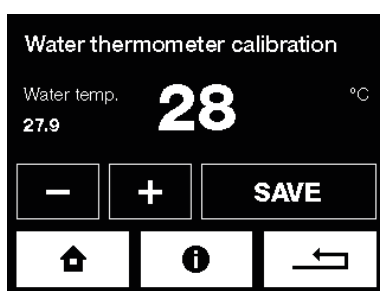

Water thermometer calibration

If the temperature of water in the pool is different from the temperature shown on ASIN AQUA Salt NET, calibrate the water thermometer in the water thermometer calibration menu.

Stabilizer in water

The water in the pool must be clean without any additives. Ideally fill the pool with fresh water from the water main.

BALANCER #13345



Alkalinity

Alkalinity volume in the water should range from **80 to 120 ppm**. Alkalinity stabilizes the pH and reduces its consumption. To increase the Alkalinity in the water, use **Pool & SPA BALANCER** (#13039).

Cyanuric Acid

The value of Cyanuric acid must be **0 ppm**. Cyanuric acid greatly diminish the effectiveness of chlorine, making it difficult to accurately measure and control its concentration.

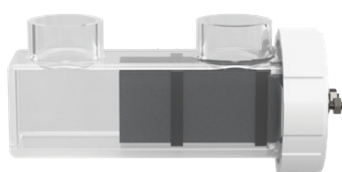

Lifespan of the electrolytic cell

Lifetime of the electrolytic cell is 8000 running hours. The electrodes in the electrolytic cell are made of titanium with a ruthenium and iridium layer. During electrolysis this layer gets consumed. Durability of the electrodes is reduced by the following parameters: Low salt content, Water temperature below 10 °C, Low water flow, Too hard water, pH below 7.0, Addition of metals containing preparations.

Maintenance of ASIN AQUA

To ensure optimal performance, ASIN AQUA requires regular visual inspection and maintenance. The table on the next page shows the schedule and recommended maintenance steps.

Replacing the pump hose

To prevent pump failure, we recommend replacing the hose every 24 months.

Replacement is carried out as follows:

- Turn off the ASIN AQUA by unplugging the power cord
- Turn the pump cartridge counterclockwise and remove it from the ASIN AQUA
- Loosen both ends of the hose and remove it from the cartridge
- Lubricate the new hose with the special grease provided
- Insert the lubricated hose back into the cartridge
- Replace the cartridge on the ASIN AQUA and secure it by turning it clockwise

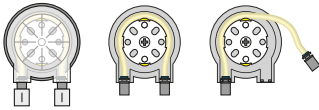
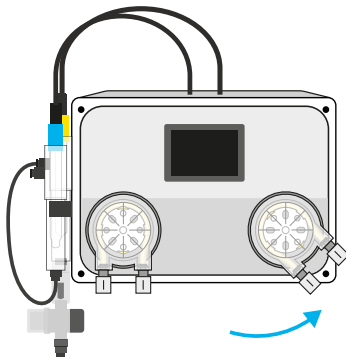

#12073 Replacement hose for PP60



#12005 Injection valve



#13087 Replacement tube (rubber band) for the injection valve



Maintenance of injection valves

Regularly check the injection valves for blockages, ensure that the rubber seals are intact, and remove any limescale.

For private pools, replace the rubber seals of the injection valves every 2 years. For public pools, replace them every year.

Probe maintenance

Remove the probe from the ASIN AQUA sump and clean it of any dirt.

Follow the instructions for the probe used.

Flow detector with filter

Rinse the flow detector strainer regularly.

Probe test

pH probe test

The pH probe can be declared functional if it meets the following criteria:

- it is not visibly mechanically damaged
- If the difference between the non-calibrated reading and the reference value exceeds ± 1.0 pH, the probe is considered faulty.

Example: the pH of the water is 7.2 and the probe measures 7.9 the tolerance is 0.7, which is less than the permitted 1.0 the probe is OK

- the probe reacts to positive and negative changes in the pH of the water or buffer

Example: if we insert a probe with a clean tip into a buffer with a pH of 7.0, the probe must respond to 90% of the range within 1 minute.

REDOX probe test

The Redox probe can be declared functional if it meets the following criteria:

- it is not visibly mechanically damaged
- The redox probe ages naturally, so its sensitivity decreases, but it should never fall below a certain limit. The permissible deviation is 50 mV; when tested with a buffer of 650 mV, it should not show less than a minimum of 600 mV
- the probe reacts to both positive and negative changes in the free chlorine content of the water

No manufacturer of pH and redox probes provides a warranty. However, ASEKO has decided to provide its customers with a two-year warranty on probes purchased together with the device, during which you are entitled to free repair of probes if they show deviations greater than those specified above.

CLF probe test

At a free chlorine concentration of 0.8 mg/l, the normal signal output from the free chlorine probe should be approximately 80 mV. If the signal at this concentration is lower than 30 mV, it suggests that there may be an issue either with the water quality or with the probe itself. In such cases, please consult the CLF probe manual and follow the recommended troubleshooting procedures to verify the probe's performance.

Test using clean water that has been left to stand for 24 hours, ensuring it is free of chlorine. In this scenario, the signal should not be above 10 mV. If the signal exceeds this value, the probe may be faulty.

ASIN AQUA Salt NET internet connection

The LAN connector connects to your home router. Data is sent every 10 seconds to pool.aseko.com; the path must not be blocked by a firewall.

Data consumption approx. 0.1 GB per month.

Connecting ASIN AQUA Salt NET to your network is not complicated, but it does require basic IT knowledge. If you do not have experience with network setup, it is better to invite an IT specialist to connect it.

Internet connection options

Home network

Connect ASIN AQUA Salt NET directly to your router using a LAN cable.

Mobile network

If you do not have direct access to the internet via Wi-Fi or a local network, you can connect ASIN AQUA Salt NET to a mobile data network using a 3G/LTE router.

Wi-Fi connection

You can connect ASIN AQUA Salt NET to your wireless network using a Wi-Fi extender.

Connect to a 230V power supply

If the ASIN AQUA Salt NET is installed in a location that is not within range of your local network or Wi-Fi, but you are using the same electrical distribution board operating on the same phase as your household, you can connect to your local network using a 230V Powerline adapter.

If you have connection problems:

If you experience connection problems, you can find a step-by-step guide called AA-Internet_Connections-Man in the Internet connection folder at manuals.asekopool.com.

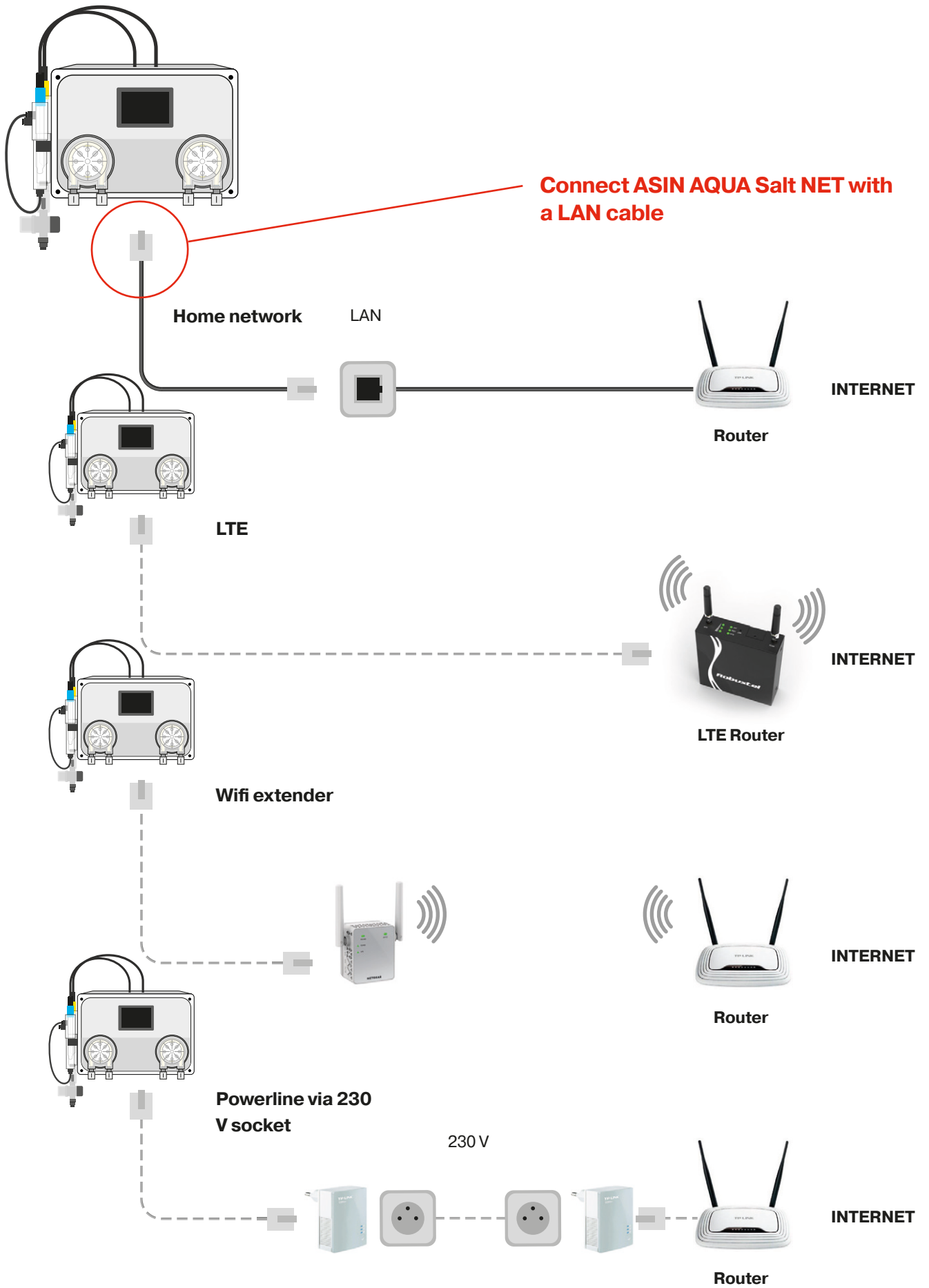

Aseko Web Services

The ASIN AQUA Salt NET can be connected to the internet using the integrated LAN adapter. You can easily monitor data from your pool at: aseko.cloud or using the Aseko Live app.

Aseko Live App

An iOS and Android smartphone app that gives you an overview of the status of your pool wherever you are connected to the internet. ASIN AQUA Salt NET automatically sends a warning message to your smartphone if one of the selected limit values is exceeded or if a system error occurs. You can easily check the amount of chemicals in the canisters to order new chemicals in time.

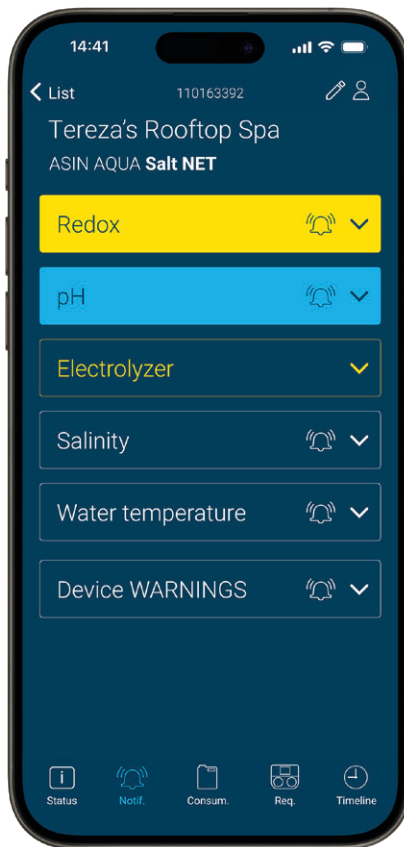

Aseko Live
for iOS



Aseko Live
for Android



<http://aseko.cloud>

A web application for detailed monitoring of pool water quality using clear graphs. It displays all measured parameters and ASIN AQUA Salt NET interventions up to 30 days back.

This application provides detailed information about the condition of the pool and a detailed overview of all events, operations performed, and the level of monitored items up to 30 days back. The clear bar chart environment provides quick information and a simple overview of the interrelationships between the monitored values. You can log in using the device serial number or through a simple registration process, where you can set up multiple measuring devices.

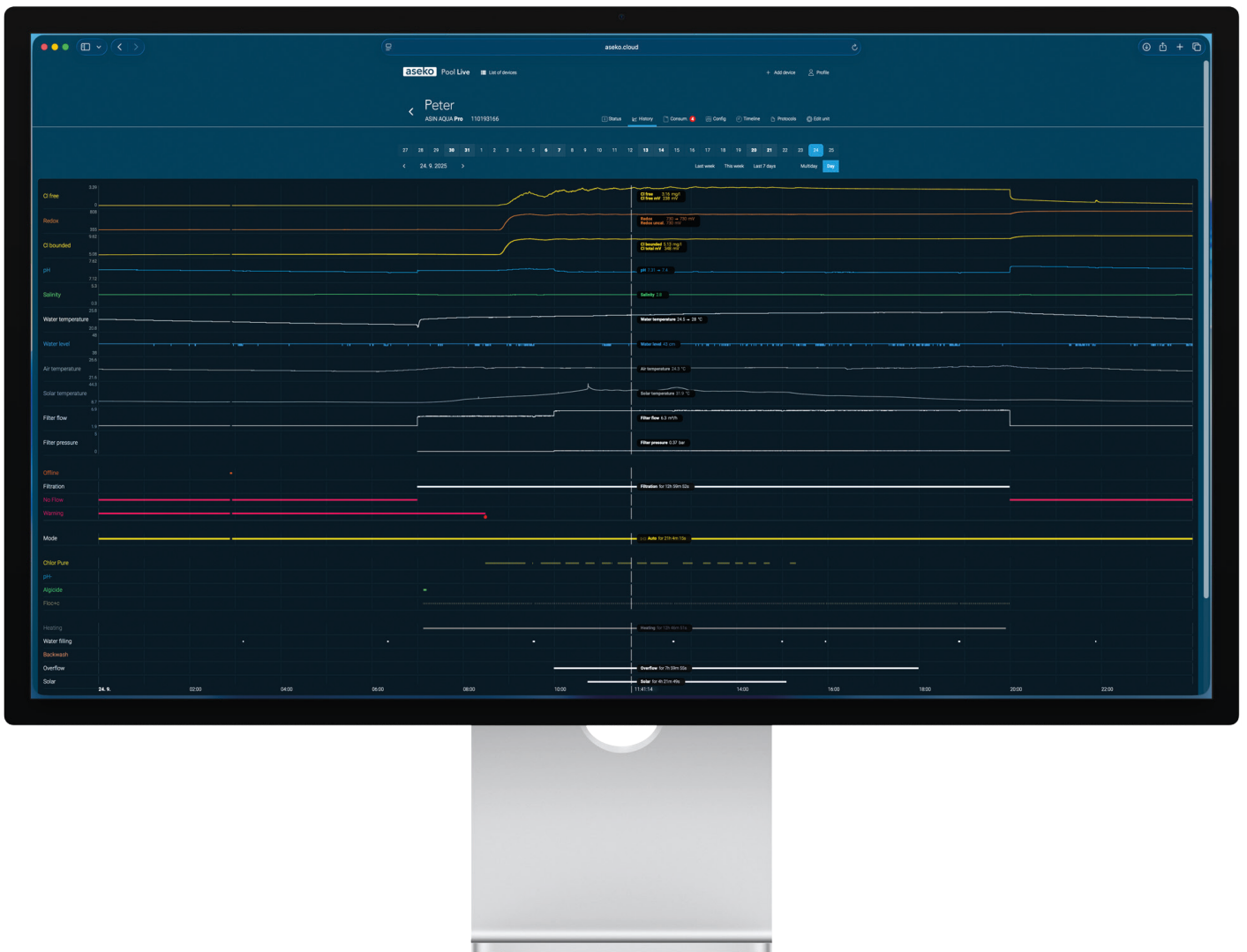

Error messages

Measured pH value wasn't reached after preset number of doses

This error message appears when:

Agent ran out

- Check liquid levels on a regular basis, refill in time.

Dosing pump does not dose

- Leakage in connection of PE tubes or they are damaged.
- Failure of dosing pump. Check whether pump is running. If so, check the hose inside the pump for damage or breakage and replace it, if required.

Injection valve clogged

- Impassable spray valve.
Check the valve for being clogged with impurities or deposits or the rubber seal for being damaged.
- Failure of dosing pump. Check whether pump is running.
If so, check the hose inside the pump for damage or breakage and replace it, if required.

No water flow to probe

- Check the measured water filter and clean it, if required.
- Check condition of connecting tubes from the extraction valve to the measured water inlet to probes and furthermore, from the water outlet from probes to the closing valve.
- Check condition of the extraction valve and the closing valve and their seals, for being clogged and their closed position.

Probe out of service

- Measure pH using the hand tester. If the pH value is too low, a respective agent was overdosed due to an incorrect probe function (provided that other reasons given in the previous points have been excluded).
- Take the probe out and check it for mechanical damage.
- Clean the probe following the above procedure.
- It is recommended to replace the probes with the new probes every two years.

The device has overheated

If the temperature in the device exceeds 65 °C, electrolysis stops.

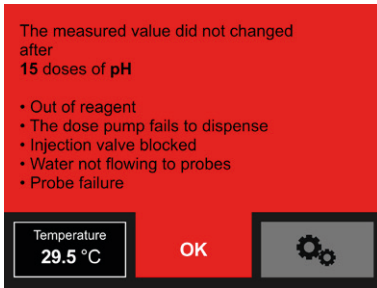

This error message appears after 15/30 doses of pH without probe reaction.

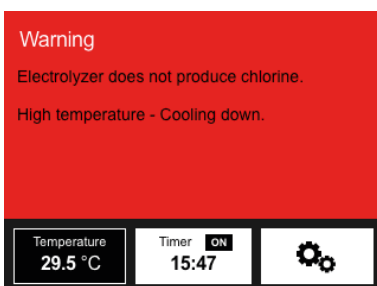

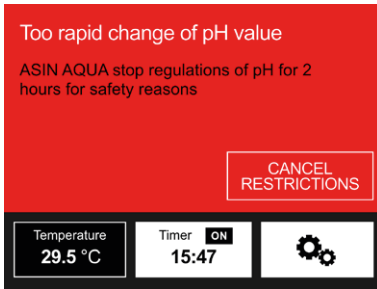

Too rapid pH change

A sudden pH change is usually caused by refilling water directly into the skimmer. When this occurs, ASIN AQUA Salt NET automatically pauses pH control for two hours. This safety limit can be disabled manually, and normal operation resumes once the pH stabilizes or the two-hour period ends.

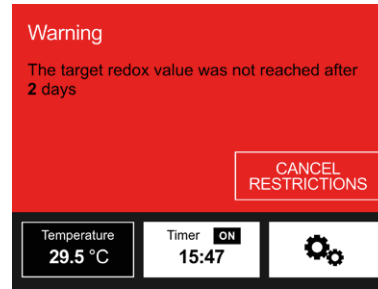

Redox / Free chlorine value not reached

If the target value is not reached after the set number of days of continuous electrolysis, this warning appears. Check the safety settings, electrode, and pool condition.

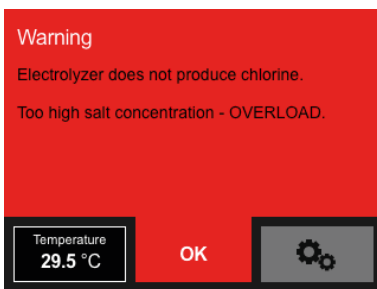

Overload

If the recommended salt concentration is exceeded, the power supply is automatically interrupted.

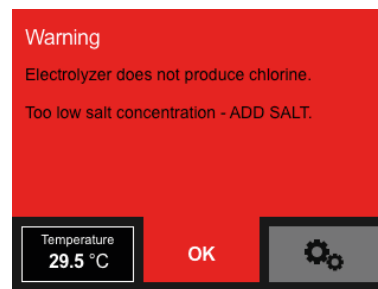

Low salt

Too low salt concentration in the water. Less than 1.5 kg/m³.

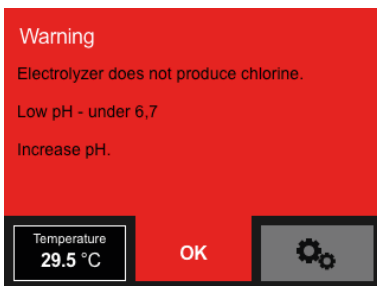

Low pH

The pH value is below 6.7, increase the pH value.

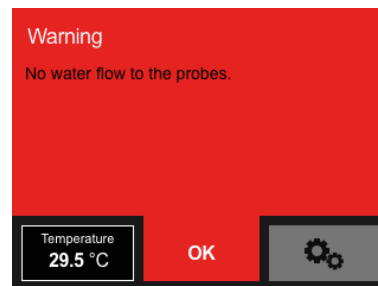

No water flow to probe

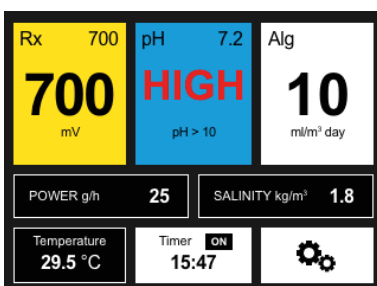

The probe shows a pH > 10

Check the pool water and probe.

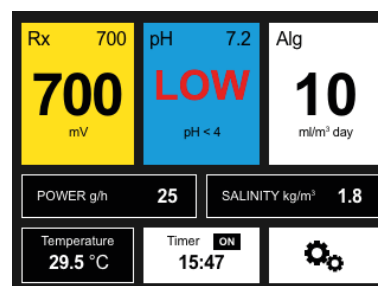

The probe shows pH < 4

Check the pool water and probe.

ASIN AQUA Salt NET

External touchscreen display

Displays measured pool water values, humidity, and air temperature. Allows you to set the disinfection level and pH. Simply touch the screen to select which parameters you want the display to show.

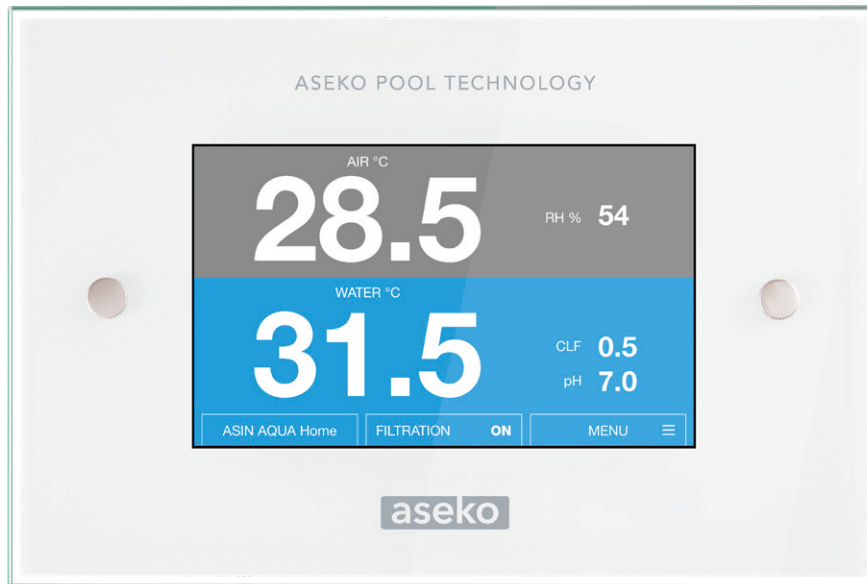

External touchscreen display #12048

USER MANUAL

ASIN AQUA Salt NET

CLF, REDOX

2025, VS Pump – FW 8.09

EN

aseko

Manufacturer: ASEKO, spol. s r.o.
Víteňská 340, 252 50 Vestec u Prahy, CZ40766471

www.asekool.com