

# ASIN AQUA Home Pro

2025

PROFESSIONAL POOL MANAGEMENT  
SYSTEM FOR PRIVATE POOLS



READY FOR  
aseko.cloud

POOL  
Live

POOL  
Rem



## General safety information

This user manual contains basic information that should be observed during assembly, start-up, operation, and maintenance. Therefore, this user manual must be read by installers and operators prior to assembly and start/up, and must be accessible to every user of this unit. Additionally, all further safety information in this document must be observed. Read and follow all instructions. In order to minimize the danger of injury, do not allow children to use this product. Non-compliance with safety information can result in hazards to persons, the environment and the equipment. Non-compliance with safety information will result in a forfeit of any potential right to damage compensation.

### Insufficient personnel qualification

Hazards in the event of insufficiently qualified personnel, potential consequence: Injury, heavy material damage.

- The system operator must ensure compliance with the required qualification level.
- Any and all work may only be performed by correspondingly qualified personnel.
- Access to the system must be prevented for insufficiently qualified persons, e.g. via access codes and passwords.

### Potential overdosing of chemical agents

Despite ASIN AQUA Home Pro comprehensive safety functions, it is possible that a probe failure and other errors could lead to an overdosing of chemical agents. Potential consequence: Injury, heavy material damage.

- Design your installation such that uncontrolled dosage is not possible in the event of a probe failure or other errors, and/or such that uncontrolled dosage is recognized and halted before damage is incurred.
- Uncontrolled overdose of chemicals can cause harm to health and property. Even though the device contains a number of security elements can not be ruled out that in case of failure of the measuring probes, or the whole device may result in overdose of chemical agents. Install the equipment so that uncontrolled overdose of chemicals was not possible and that uncontrolled overdose has been detected in time before causing any harm. It is necessary to use chemicals in such quantities that an overdose will not cause dangerous concentration of chemical agents. Do not use chemicals in too large packages or with too high concentration.

### Gaseous chlorine produced from dosing in standing water if dosing outputs are not closed via the filter pump

If the flow switch is stuck or experiences another error, there is a risk of dosing into standing water. Poisonous chlorine gas can be yielded when sodium hypochlorite and pH minus come together.

### Non compliance with informational text

Not observing informational text may lead to hazards. Potential consequence: gravest degree of injury, heavy material damage.

- Read all informational text carefully.
- Cancel the process if you are unable to exclude all potential hazards.

### Use of new functions

Because of the continued development, a ASIN AQUA Home Pro unit may contain functions, which are not completely described in this version of the user manual. The use of such new or extended functions without a profound and secure understanding by the operator may result in malfunctions and severe problems. Potential consequence: Injury, heavy material damage.

- Make sure to get a profound and secure understanding of a function and relevant boundary conditions, before you start to use it.
- Check for an updated version of the user manual or additional documentation available for the relevant functions: <http://manuals.asekopool.com>
- Make use of the integrated help function of the ASIN AQUA Home Pro to get detailed information on functions and their parameter settings.
- In case it is not be possible to get a profound and secure understanding of a function based on the available documentation, do not use this function.

## Overdosing if pH value is wrong

If disinfection is enabled before the pH value is stable in the ideal range of 6.8 to 7.5, then it may lead to heavy overdosing of chlorine or bromine. Potential consequence: Injury, heavy material damage.

- **Do not start disinfection with chlorine until the pH value is stable in the ideal range between 6.8 and 7.5.**

## Conditions before using

Make sure you have a newest and updated version of the user manual and other documentation for all functions of the unit. Use and read the integrated help features. In case of not understanding the information about certain features of the unit, do not use these features.

## Handling chemicals for pool water treatment

The chemicals used with the ASIN AQUA Home Pro must be handled in a safe manner to prevent damage or personal harm. Aseko recommends you always use personal protective safety equipment when handling the pH and chlorine agents. Refer to the Materials Safety Data Sheet (MSDS).



## Important notices for proper functioning.

### **WARNING:**

#### **Never mix pH and chlorine agents.**

Always rinse tubes and valves with clean water during maintenance to prevent mixing.

#### **Never use hydrochloric acid (HCl, muriatic acid, spirits of salt, hydronium chloride, chlorane).**

HCl acid is fuming. Using a chemical based on HCl will cause damage to the device.

**Never install the unit in unventilated technical shafts with high humidity, as this can severely damage electronic components, especially the display. Damage caused by high humidity will not be accepted as a warranty claim.** If the ASIN AQUA Home Pro is in a high-humidity and low-temperature environment (e.g., garden house), keep the device permanently ON. This helps maintain a higher internal temperature, significantly reducing humidity inside the unit. The same applies when storing the unit during winter.

#### **Installation must be protected by a residual current device (RCD).**

#### **The pool and pool technology must be properly grounded.**

#### **CLF Probe Calibration:** Calibration can only be done when the pH is stable in the range of **6.8–7.5**.

After changing the electrolyte, wait at least **1 hour**, but ideally **24 hours**, to allow the signal to stabilize before proceeding with calibration.

#### **Never use stabilizers with cyanuric acid in ASIN AQUA devices.**

Cyanuric acid forms a chlorine-cyanurate complex, which rapidly decreases the disinfecting power of chlorine and makes it impossible to measure with a free chlorine probe. Be aware that some chlorine tablets contain cyanuric acid. Ensure there is no cyanuric acid in your pool.



**MAX POOL VOLUME**  
250 m<sup>3</sup>

## ASIN AQUA Home Pro

ASIN AQUA Home Pro is an advanced system for pool water treatment and pool technology management. The system provides water disinfection with chlorine or chlorine-free methods, precise pH regulation, and dosing of algicide and flocculant to ensure clear water with minimal use of chemical agents.

The Pool Technology Management functions automate pool operations and reduce the need for manual maintenance. All information about water quality is displayed on the integrated touchscreen, which also allows configuration of the entire system.

ASIN AQUA Home Pro introduces new functions, including remote monitoring and control via mobile and web application, enabling full access to pool parameters and settings from any location with internet connectivity.

## Pool water treatment



### Chlorine control

With precise chlorine measurement via ASEKO CLF or Long Life Redox probe and advanced digital intelligence, ASIN AQUA Home Pro provides highly effective and reliable pool water disinfection.

### pH control

Accurate measurement by pH probe long-life in combination with the dosing algorithm assures the required pH level.



### Never use hydrochloric acid

(HCl, muriatic acid, spirits of salt, hydronium chloride, chlorane). HCl acid is fuming. Using a chemical based on HCl will cause damage to the device.

### ALGICIDE

The effective polymeric biocide protects water against algae, fungi, moulds and bacteria.

### FLOC+C

FLOC+C contains flocculation and coagulation components. Its continual dosing improves filtration capability of removing even the smallest impurities.

### Filter Sanitization

An optional PP60 pump can be connected to the filter disinfection output. This pump activates automatically during the backwash cycle to ensure thorough sanitization of the filter using liquid chlorine. The filter is completely disinfected, and no additional chlorine enters the pool, as the chlorinated water is discharged to waste during backwash.

# Pool technology management

## Filtration Time Control

Daily, automatic start of the filtration system in 4 individually pre-set periods.

## Water Level - Refilling

### Pressure level sensor.

Water level can be monitored by optional **pressure level sensor**. System can be programmed to control four different water levels at your pool and switch the water refilling or automatically use the excessive water for filter backwash.

**Float level detector** controls two levels for switching the automatic water refilling.

## Filter Backwash

The system can control the filter backwash time interval and periods this function requires an optional **5-way Besgo valve**.

## Filter disinfection

ASIN AQUA Home Pro disinfects the filtration system during filter backwash.

## Smart Heating Control

The system is equipped by intelligent control of pre-set water temperature. It can switch and control the heating (**solar heating, electrical heating, gas heating, heat exchanger**) by logic of integrated smart heating functions.

## Winter mode

The Winter mode ensures the pool remains at a safe temperature during cold weather conditions.

## Variable speed pump control (VS pump)

In the settings, select the type of your variable speed pump. ASIN Aqua allows to use 4 speeds:

Speed 0 (OFF)

Speed 1 (LOW)

Speed 2 (MEDIUM)

Speed 3 (HIGH)

## Switching BOTTOM / OVERFLOW

The ASIN AQUA Home Pro system allows you to precisely configure whether you want to use the overflow or bottom drain in your pool. In auto mode, there are four periods where you can individually select BOTTOM or OVERFLOW for each period.

This function requires optional **3-way Besgo valve**.

## Pool cover position (relay closed)

If the pool cover is closed during the set TIMER times, the speed of the VS pump will automatically change to 1 (LOW).

## Pool cover movement (relay closed)

When the cover is moving, ASIN Aqua automatically switches off the filtration pump.

## Control by External touch display

ASIN AQUA Home Pro can be monitored and controlled by external touch display this function requires an optional **External touch display**.

## Mode settings

Six adjustable automatic modes for easy pool control.

## Programmable relays

ASIN AQUA Home Pro has one integrated programmable relay to control an extra accessory. Possibility to connect optional **RL module** (relay module) to connect 4 extra relays.

## Solar heating control

ASIN AQUA Home Pro monitors the temperature of solar panels. When solar panels reach a set threshold, the water is automatically redirected to the solar panels. This function requires an optional **4-way Besgo valve**.

# What is in the box

ASIN AQUA Home Pro



Probe housing 2 pcs  
#13013

Water thermometer PT1000  
with holder  
#13066

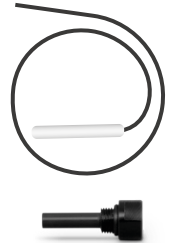

Peristaltic pumps #13024

Flow detector with filter  
#12106

CLF probe  
#12052  
(only for ASIN AQUA HOME Pro CLF)



or

Redox probe Long Life  
#12016  
(only for ASIN AQUA HOME Pro Redox)



pH probe Long Life  
#12012



Measuring water valve 2 pcs  
#12006



PE Tube 1/4 (6,35mm) 20m  
transparent #13278



Mounting rail  
#13430



Dowels and screws  
#12125



Cap with suction tube housing for  
20l canister 4 pcs  
#13415



Injection valve 4 pcs  
#12005



Coagulation mixer d 50, L 195 mm  
#30001  
(only for ASIN AQUA Home Pro OXY)



#12177 OX tester  
(only for ASIN AQUA Home Pro OXY)



# Optional accessories

PP60 PRO (12 V) 3,6l/h  
#12053



Injection manifold d50/DN63  
4x 1/4" #13395



Coagulation mixer d 50, L 195 mm  
#30001

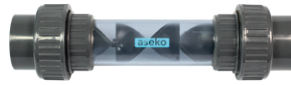

External touch display  
#12048

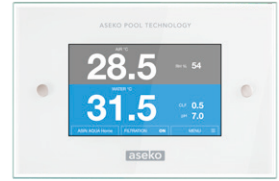

#13364  
FlowVis d63mm flow meter  
with non-return valve



Level sensor (pressure-type)  
#12086



Air / Solar thermometer  
#13193



RL Module  
#13065



Inserting DN50 plug  
1/4" threaded #12134



Digital Photometer Aseko  
#13449



pH 7.00 Buffer #12065  
Redox Buffer #12091



Filter pressure meter  
#13426



BESGO 5-way  
#83103  
BACKWASH



BESGO 3-way  
#83130  
OVER /BOTTOM



BESGO 4-way  
#83150  
SOLAR



# ASEKO original chemical solution

## 20 l or 5 l volume

CHLORPURE #12075  
(only for CLF and Redox)



OXYPURE #13038  
(only for OXY)



pH MINUS #12130



pH PLUS #12120



ALGICID #12156



FLOC+C #12139



## Volume 10 kg

BALANCER #13345



MAGNESIUM #13346



## Bottle 1 kg

SUPER CHLOR #13120



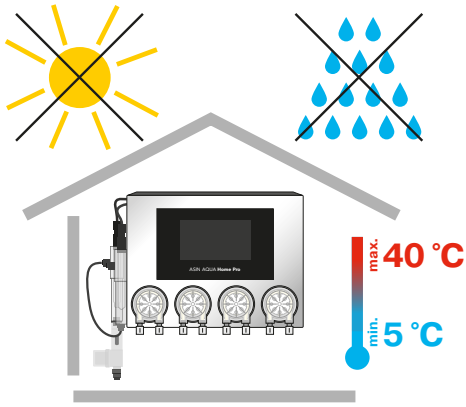

# ASIN AQUA Home Pro Installation

The ASIN AQUA Home Pro must be operated in indoor environment with a temperature range of +5 to +40 °C, and the relative humidity must not exceed 70 %. Direct sunlight, high humidity, and dust may damage the ASIN AQUA Home Pro.

- Before installing, ensure that pool water is chemically clean and without dirt.

Install the mounting rail and attach the ASIN AQUA Home Pro to the wall. Choose a location with a free space of at least 40 cm in all directions, and a height above the floor must not be higher than 150 cm.

- The vertical distance between ASIN AQUA Home Pro and the bottom of containers must not exceed 2 m.
- The maximum distance from injection valves to peristaltic pumps must not exceed 8 m.

**RECOMMENDATION:** Install the ASIN AQUA Home Pro so that even in case of leakage of chemicals from the pumps or pipes, there is no damage to other equipment or spillage on the floor. Use drip trays.

Do not install any other devices under ASIN AQUA Home Pro.

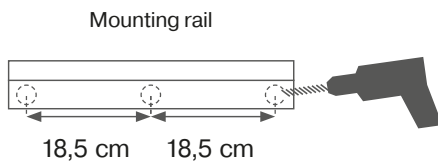
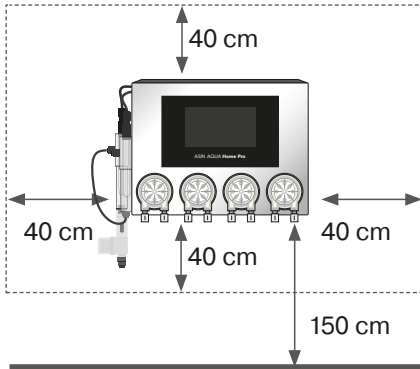

## **WARNING:**

**Never install the unit in unventilated technical shafts with high humidity, as this can severely damage electronic components, especially the display. Damage caused by high humidity will not be accepted as a warranty claim.** If the ASIN AQUA Home Pro is in a high-humidity and low-temperature environment (e.g., garden house), keep the device permanently ON. This helps maintain a higher internal temperature, significantly reducing humidity inside the unit. **The same applies when storing the unit during winter.**

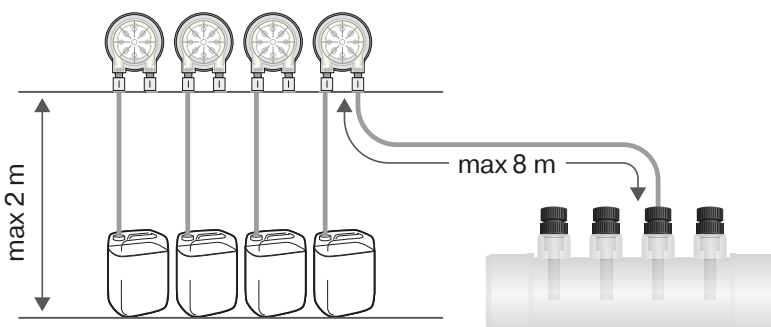

# Installing the Probes

1. Carefully insert the pH, and CLF or REDOX probe into the housing.
2. Hand tighten or use the plastic wrench socket for probes.
3. Connect the CLF or Redox probe with yellow marked cable and pH probe with blue marked cable.

After probes have been inserted, slightly tightened and connectors have been connected, ASIN AQUA Home Pro is ready for connection to the water system of your pool.

**WARNING:** Only hand-tighten the probes or use the plastic probe wrench. Do not use pliers or a steel wrench. The tightening torque is 3 Nm.

## Step 1: Installation of pH probe

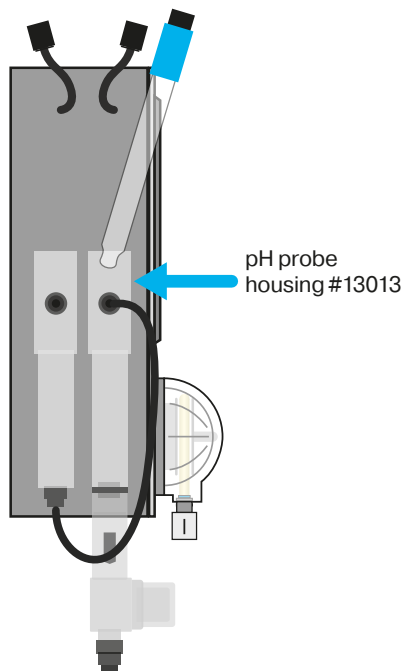

pH Long Life probe  
#12012



## Step 2: Installation of CLF or Redox probe (for CLF and Redox)

CLF probe  
#12052



Redox probe  
Long Life  
#12016

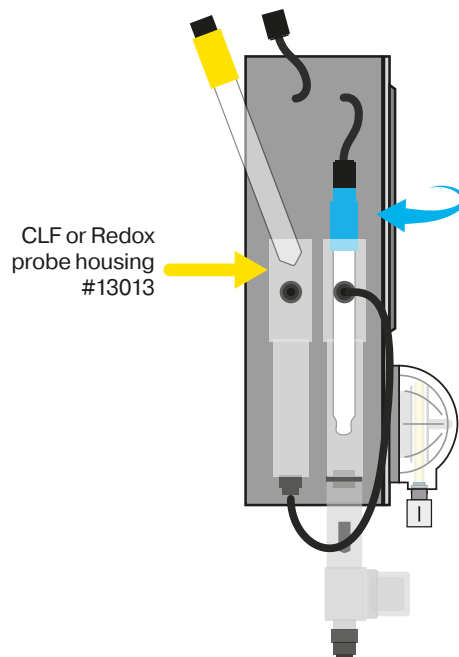

Wrench socket for  
probes #13046



# Pool Water Connection

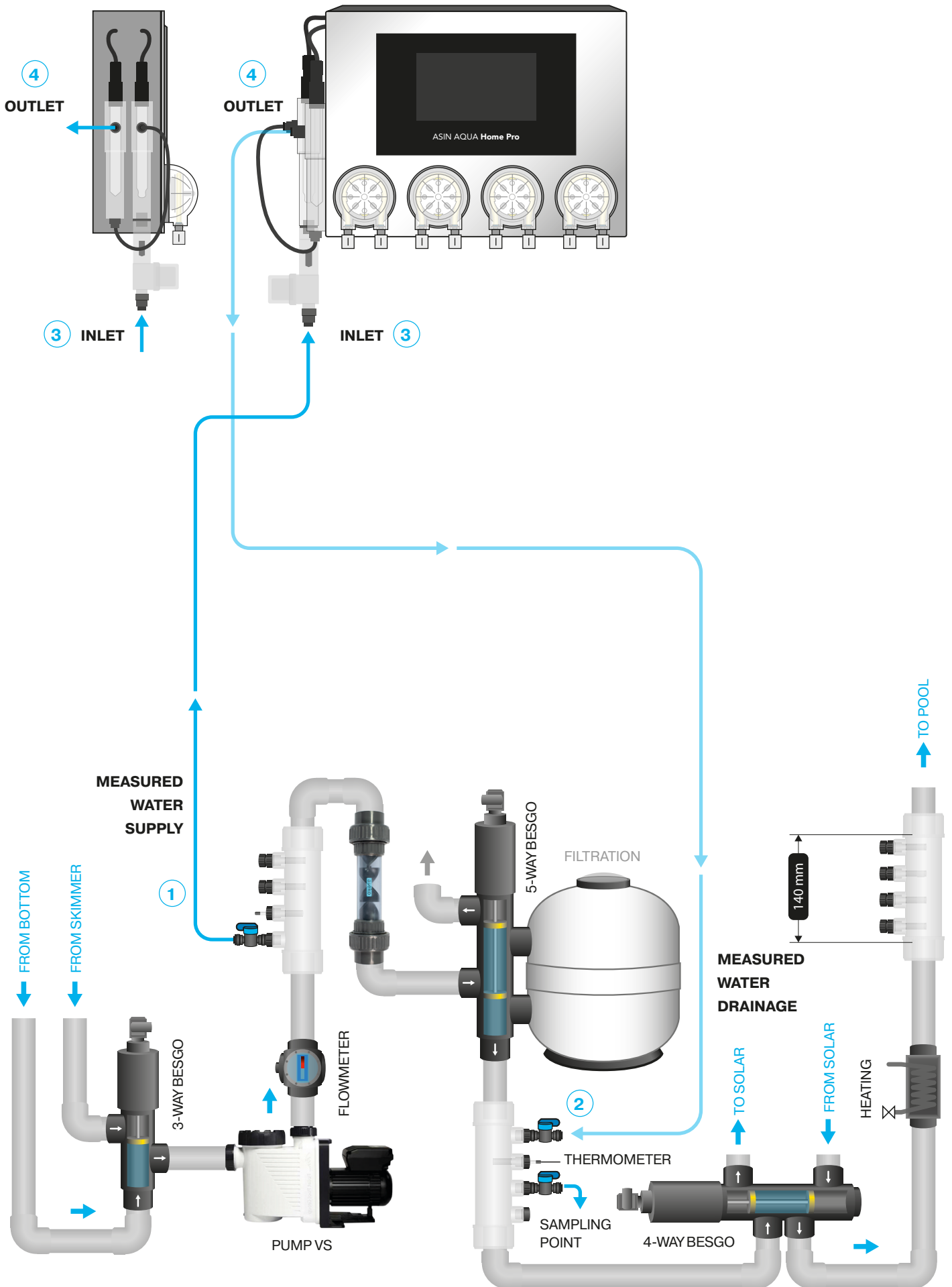

# Pool Water Connection

Screw the **measuring water valve** in the injection manifold 4x 1/4".  
**Tighten the measuring water valve into the injection manifold by hands only. Do not use pliers or other tools.**

- 1 Connect the **MEASURED WATER SUPPLY** to the pipe **behind the pump, and before the filter and before the coagulation mixer.**
- 2 Connect the **MEASURED WATER DRAINAGE** to the pipe **behind the filter** and behind the heating or into the overflow tank or skimmer.

## WARNING

Do not connect water supply to probes after the filter and return before the pump. Negative pressure significantly affects measurement.

To connect the measured water to the ASIN AQUA use PE tube 1/4 "(6.35 mm) #13277, which is part of the packaging.

## WARNING

Cut the PE tube at an angle of 90° to ensure tight joints. The cut must be clean. Use special pliers #13325 to cut plastic tubes. Do not use common scissors or knives!

The measured water is easily connected to ASIN AQUA using the **Speedfit** push-in fitting.

- 3 **CONNECTION** Push the connecting pipe into the Speedfit fitting and pull out the hose to secure.
- 4 **DISCONNECT** push and hold the Speedfit round collet and pull out the connecting pipe.

**INLET** of the measured water to the ASIN AQUA  
 Connect the tube to the bottom Speedfit of the measured water filter.

**OUTLET** of the measured water from ASIN AQUA  
 Connect the tube to the side Speedfit on the probe housing.

Once connected, ASIN AQUA is ready to measure disinfectant content and pH value in your pool.

Place a Plug with 1/4" thread (#13082) on unused threads of Injection manifold.

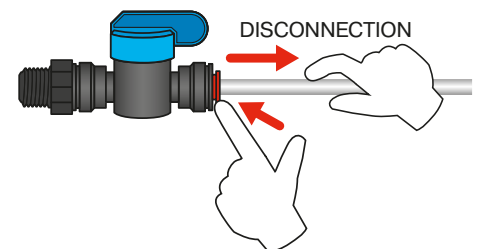
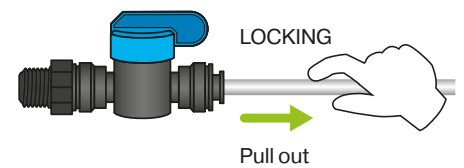
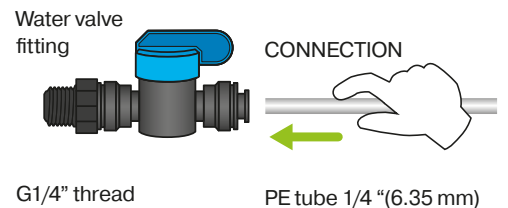
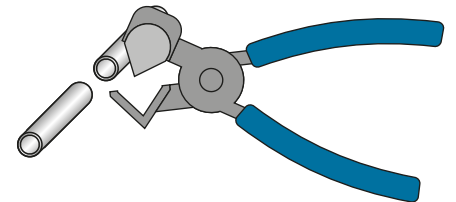
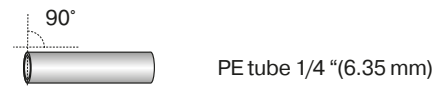
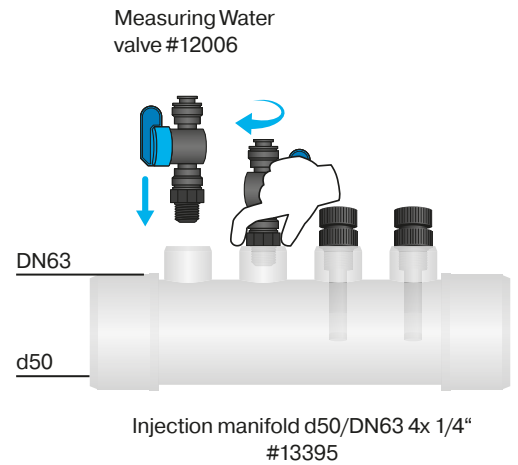

# Pool Chemicals Connection

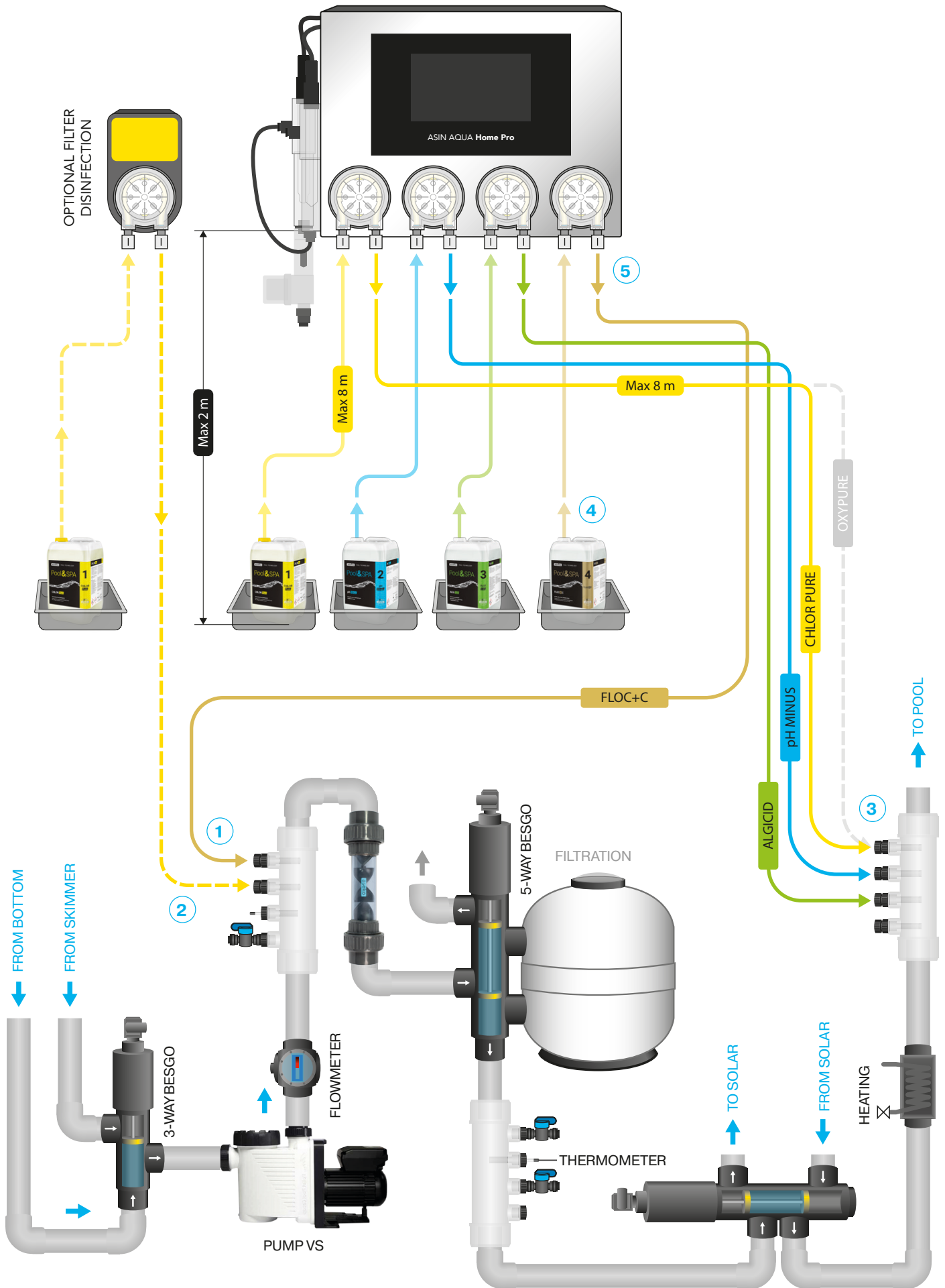

# Pool Chemicals Connection

Screw the **injection valve** in the injection manifold 4x 1/4" #13395.

**Tighten the injection valve into the injection manifold by hands only.**

**Do not use pliers or other tools.**

- 1 Connect the **FLOC+C INJECTION VALVE** to the pipe **before the coagulation mixer and before the filter and after the MEASURED WATER SUPPLY**.
- 2 Connect the **FILTER DISINFECTION INJECTION VALVE** to the piping **before the besgo 5 way valve and before the filter and after the MEASURED WATER SUPPLY**.
- 3 Connect the **ALGICIDE, pH-, and CHLOR PURE INJECTION VALVE** to the pipe **behind the filter and behind the MEASURED WATER DRAINAGE**. Connect injection valves in this order to prevent formation of lime scale.

To connect reagents from cans to the dosing pumps and from the dosing pumps to the injection valve use PE Tube 1/4" (6.35 mm) # 13277, which is part of the packaging.

## WARNING

Cut the PE tube at an angle of 90° to ensure tight joints. The cut must be clean. Use special pliers #13325 to cut plastic tubes. Do not use common scissors or knives!

- 4 **CANISTER CONNECTION** Use the Suction kit for 20l canister #13415. Put the PE tube through the cap so it ends right over bottom of the canister.
- 5 **PUMP CONNECTION** Connect the can with the left (suction) connector of the pump using a PE tube from the can.
- 6 **INJECTION VALVE CONNECTION** Pass the tube through the injection valve nut, connect the tube into the injection valve and tighten the nut firmly by hand. Connect the tube from injection valve with the right (discharge) connector of the pump.

## WARNING

**NEVER CONNECT pH minus reagent to disinfection pump or disinfectant to pH pump!** In the case of a cross-connection, after ten doses ASIN AQUA displays an error message. Repair the piping installation and then you can continue to operate your ASIN AQUA.

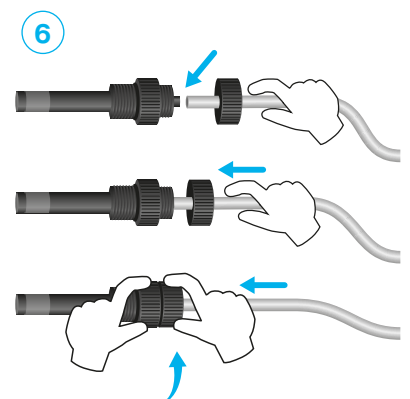
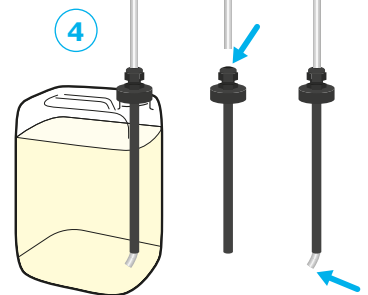
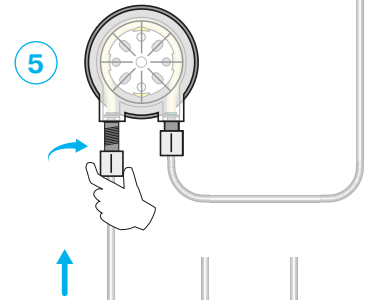
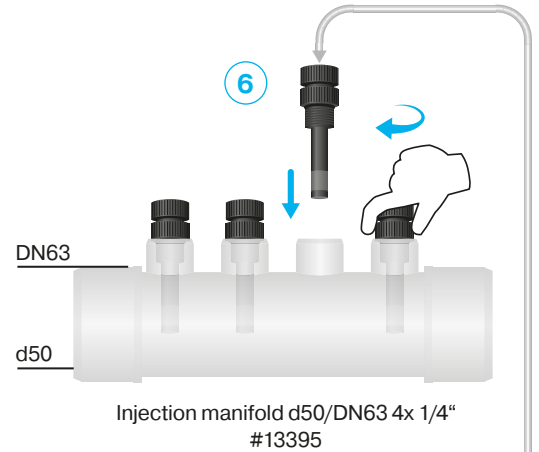

# Electrical Connection

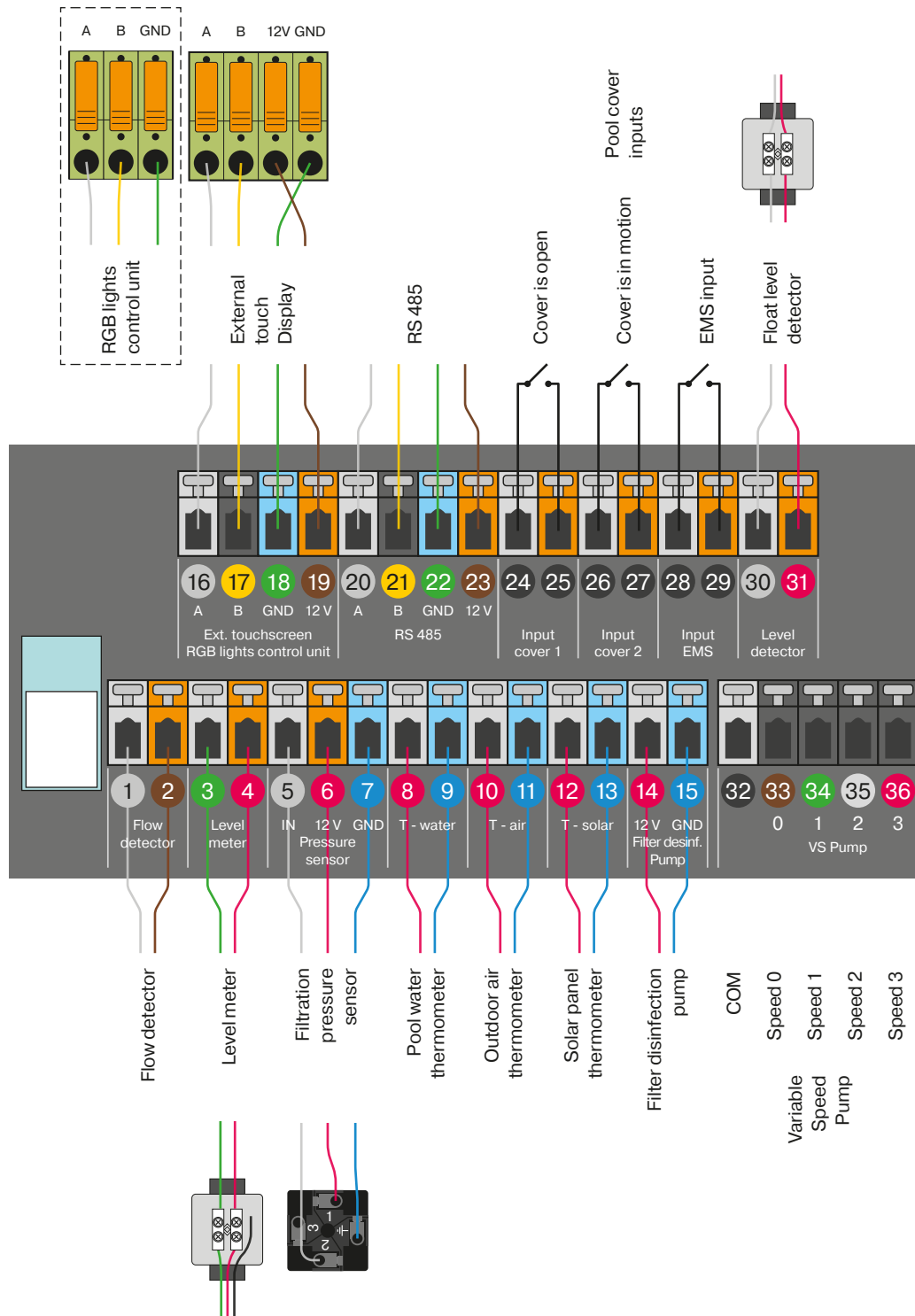

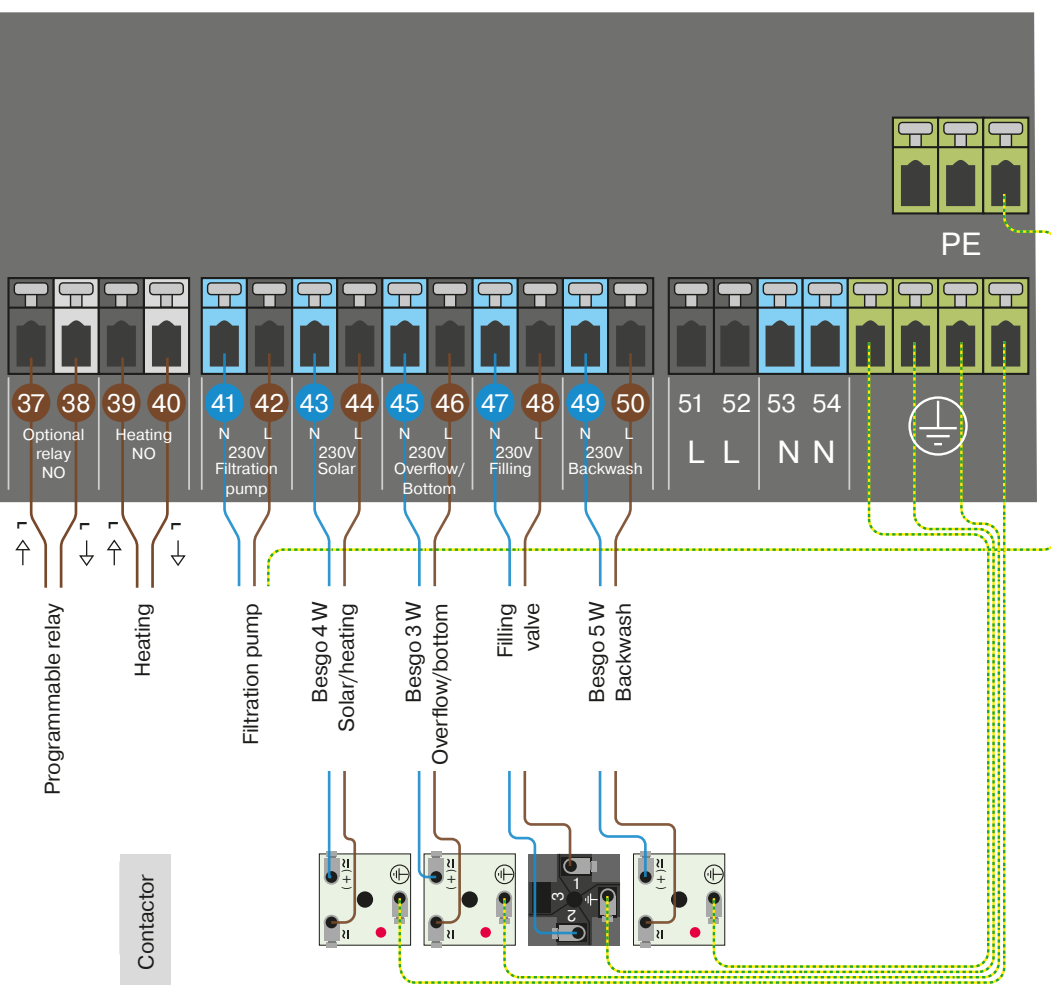



**Installation must be protected by a residual current device (RCD).**

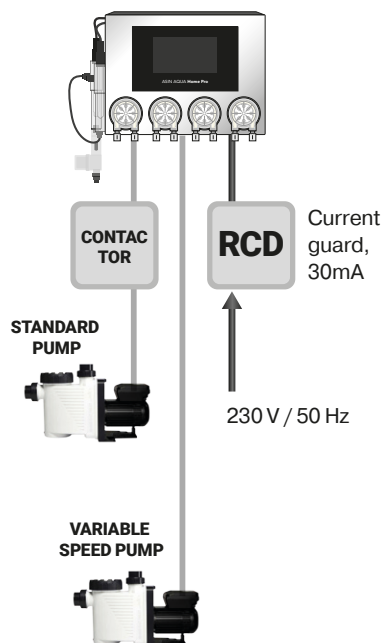

## Power Supply

### Connection to the mains:

1. Leave the mains switch in the OFF position.
2. Connect the 230 V/50 Hz mains cable to ASIN AQUA Home Pro. The mains socket outlet must be protected by a residual current device (RCD).
3. Change the mains switch over to the ON position.

After Device has been switched on, the display will come on and the ASIN AQUA Home Pro starting screen will appear.

### Disconnection from the mains:

1. Change the mains switch over to the OFF position.
2. Disconnect the ASIN AQUA Home Pro mains cable from the 230 V/50 Hz.

**WARNING:** If Device is used in the manner different from that specified by the manufacturer, protection provided by Device may get damaged.

Power supply	230 V/50 Hz
Power consumption	24 VA
Fuse	T1 A; T6.3A
Over-voltage category	II
Ingress protection	IP40
Operating temperature	+5 to +40 °C
Weight	6,7 kg
Installation	wall mounted
Measured water pressure	max. 1 bar (must not be vacuum)
Dimensions	430 x 330 x 160 mm

# Filtration pump

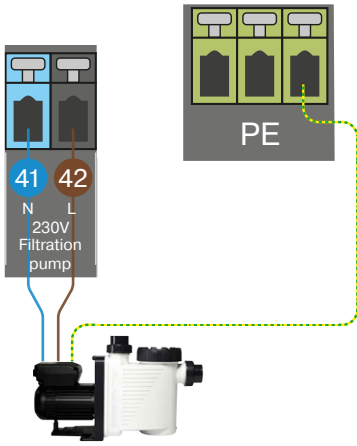

## WARNING

Always check the connection according to the current user manual of your pump manufacturer.

### 1) Filtration pump

Connect the filtration pump to outputs **41, 42** and **PE**.

2

### 2) Variable speed filtration pump

Connect to outputs **32 to 36**, connection depends on the type of variable pump.

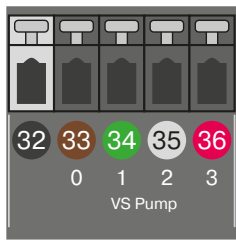

TYP A					TYP B					TYP C				
COM	S1	S2	S3	STOP	COM	S1	S2	S3	S4	COM	S1	S2	S3	STOP
n1	ON	OFF	OFF	OFF	n1	ON	OFF	OFF	OFF	n1	ON	OFF	OFF	OFF
n2	OFF	ON	OFF	OFF	n2	OFF	ON	OFF	OFF	n2	OFF	ON	OFF	OFF
n3	OFF	OFF	ON	OFF	n3	OFF	OFF	ON	OFF	n3	OFF	OFF	ON	OFF
S	OFF	OFF	OFF	ON	S	OFF	OFF	OFF	ON	S	ON	ON	ON	OFF

Speed (circled around S1 in TYP A)

Relay status (circled around S in TYP A)

2

#### SPECK (older type)

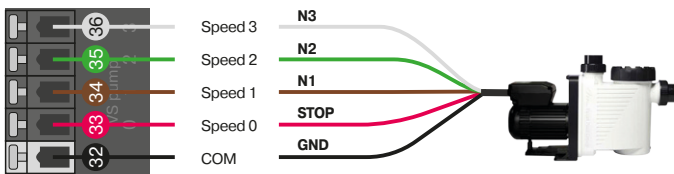

#### TYP A

#### HAYWARD KS Evo VS

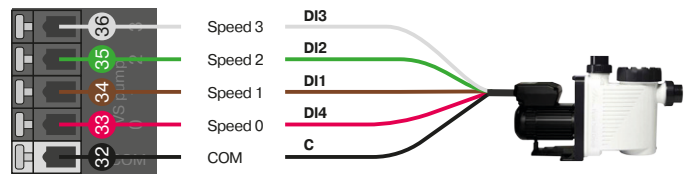

#### TYP A

#### SPECK

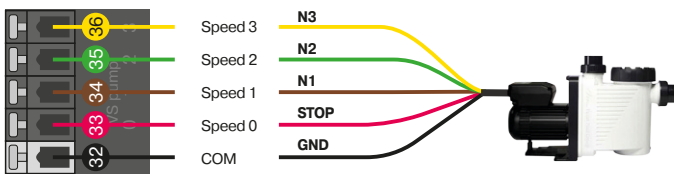

#### TYP A

#### PENTAIR

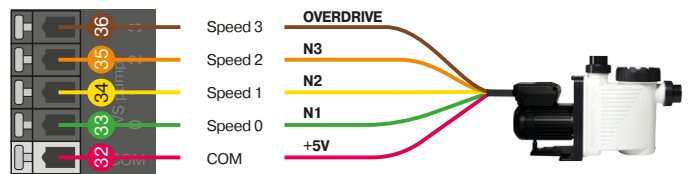

#### TYP B

#### AQUAGEM INVERPRO

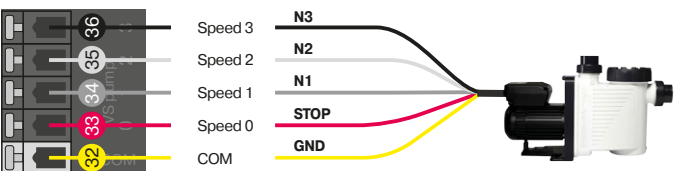

#### TYP A

#### DAB E.SWIM - E.PRO

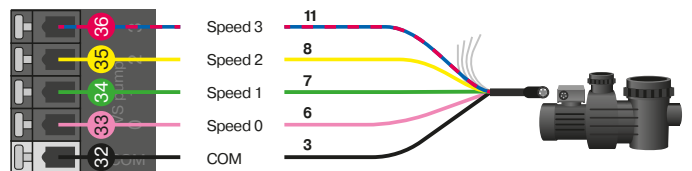

#### TYP B

#### UWE EO PM

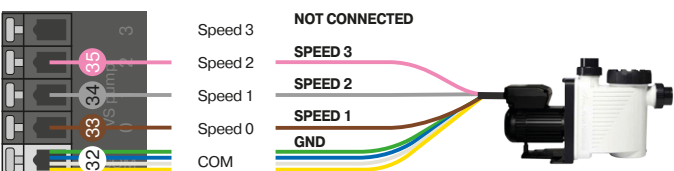

#### TYP A

#### HAYWARD (older type)

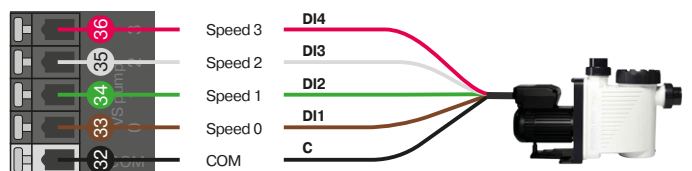

#### TYP C

# Equipment connection

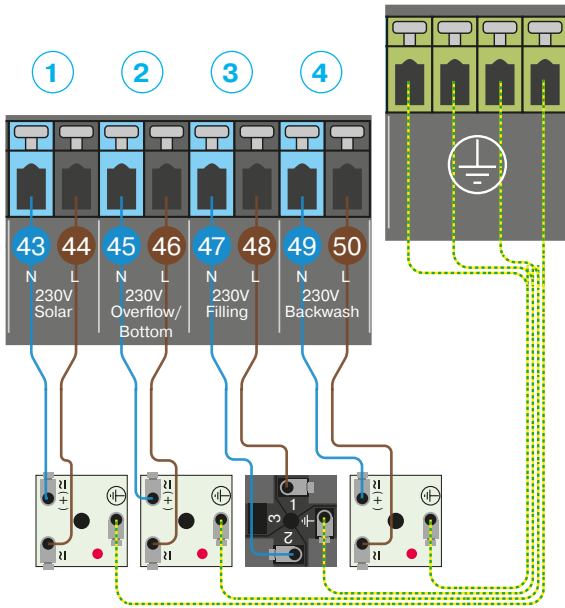

## 1) Solar (4 way Besgo valve)

Connect to the 230 V outputs **43** (blue N) and **44** (brown L).

## 2) Overflow/Bottom (3 way Besgo valve)

Connect to the 230 V outputs **45** (blue N) and **46** (brown L).

## 3) Filling solenoid valve

Connect to the 230 V outputs **47** (blue N) and **48** (brown L).

## 4) Filter backwash (5 way Besgo valve)

Connect to the 230 V outputs **49** (blue N) and **50** (brown L).

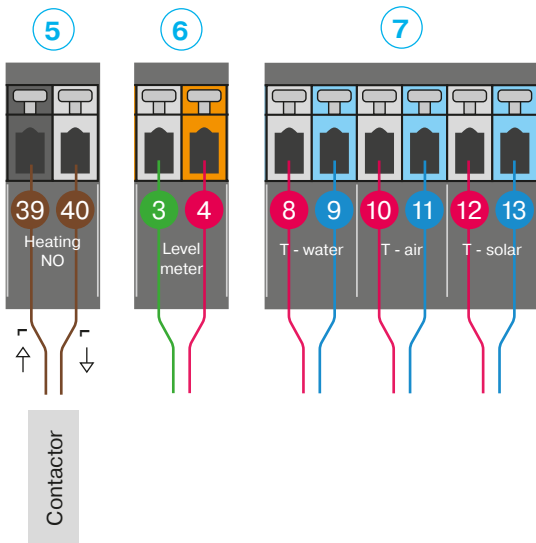

## 5) Heating

Connect to the non potential outputs **39** and **40**.

To connect the heating system, it is recommended to use a contactor.

## 6) Water level meter (pressure)

Connect to the green wire to the terminal **3** (green) and red wire to the terminal **4** (red).

## 7) Thermometers

T – water connect to the terminals **8** (red) and **9** (blue).

T – air connect to the terminals **10** (red) and **11** (blue).

T – solar connect to the terminals **12** (red) and **13** (blue).

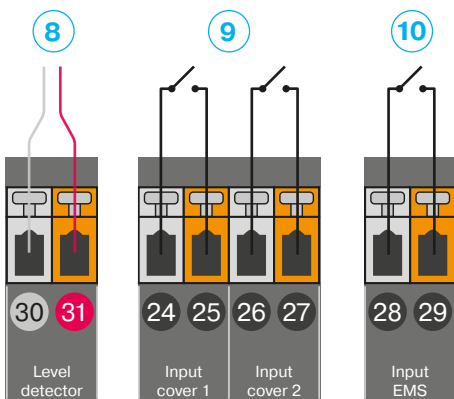

## 8) Float level detector

Connect the logical input to outputs **30** and **31**.

## 9) Cover position detection

Connect the logical input for closed cover detection to outputs **24** and **25**, and connect outputs **26** and **27** to detect cover movement.

## 10) Input EMS (Energy Management System)

Connect the logical input to outputs **28** and **29**.

# Touch screen description

Required Value

Free chlorine 0.5 mg/L

pH - 7.0 pH

Measured value

Dosing pump status ON-dosing

Algicid 10 ml/m<sup>3</sup> day

Flocc 14 ml/hour

Water 30.0 °C Smart heating

Air 29.0 °C

Solar 36.0 °C Pump STOP

Water level OK Filling STOP

Pool flow OVER

Filter pressure 0.90 bar

Backwash next in 14 days

Pump Medium

Relay Pulse

11:30 14.07. Mode AUTO

40 m<sup>3</sup>

Calibration

Settings

Current mode

Pool volume

Calibration menu

Settings menu

Current mode

Switch the mode

Decrease the value

Increase the value

Water °C 28.5

Temp. is superior to filtration

START STOP SPEED FLOW

Morning 06:00 08:00 Low Bottom

During day 08:00 15:00 Medium Over

Afternoon 15:00 22:00 High Over

Night 22:00 06:00 Low Bottom

Back

Name

Settings

Serial No: 110013158  
FW Disp: 1.1  
FW Main: 1.0

Language ENGLISH

Relay test TEST

Function activated

Variable speed pump Type of VS pump TYPE A

Delay time After a DOSE min. 10 After a the START min. 20 SETTINGS

Back to the previous screen

Displays info for the current screen

Previous page

Current page / number of pages

Next page

# Installation test

**WARNING:** Any obstacles, bubbles or leaks in the connecting tube will prevent ASIN AQUA Home Pro from correct operating. The clear plastic tube allows you to monitor flow of liquid to the injecting valves.

Before commencing the operation, test ASIN AQUA Home Pro installation.

**Most problems result from incorrect installation.**

## Test

In the “Relay Test” menu, start pumps one by one and while they are running, check tightness of all the PE tube connections. Check the injecting valves for blockage and PE tube for air bubbles.

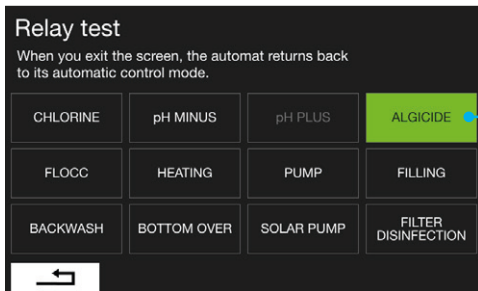
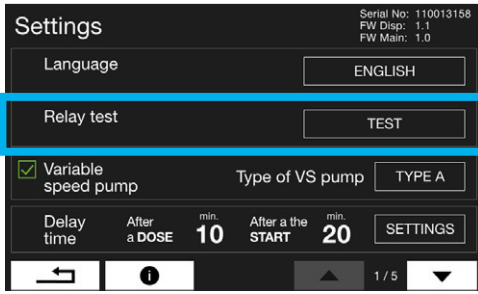

Press to **TURN ON (GREEN)** and press again to **TURN OFF**.

**DON'T FORGET!** After you complete the test, stop all accessories in the menu. Do not dose in this step!

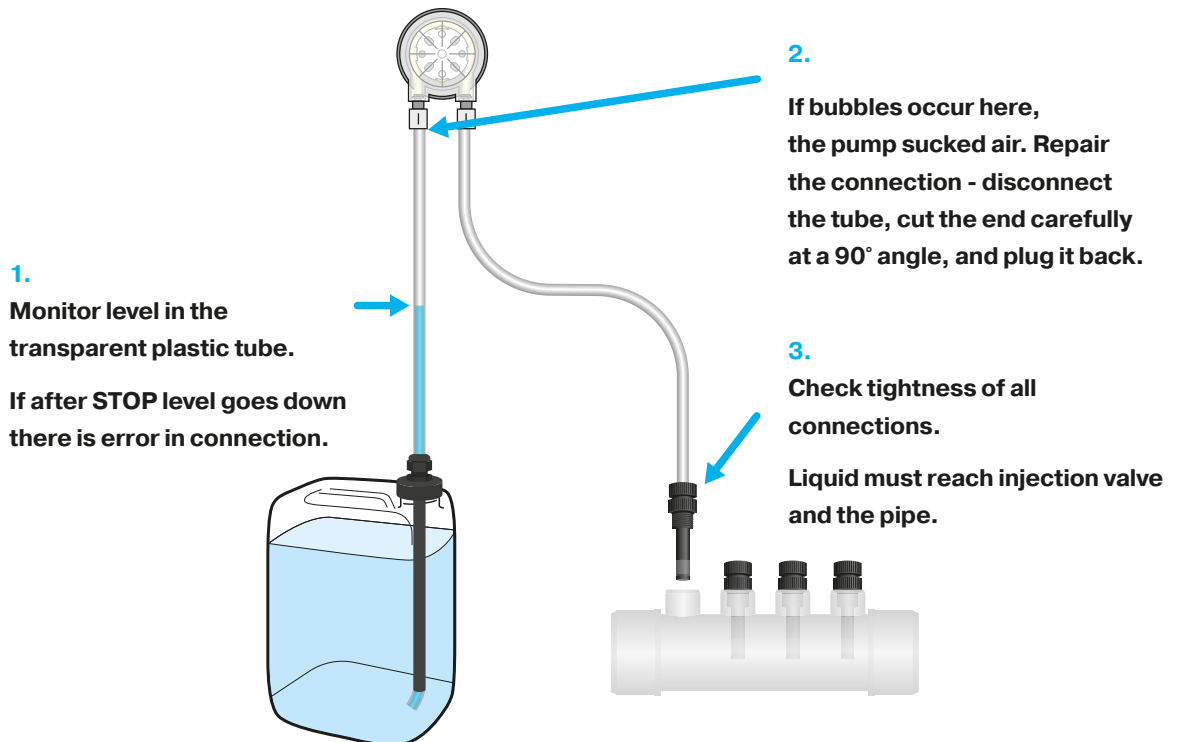

# Choosing the type of probe or the type of time dosing

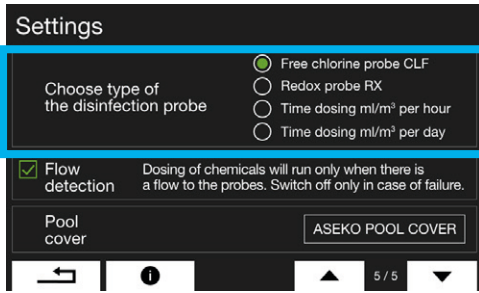

1. **CLF free chlorine probe** for ASIN AQUA Home Pro CLF  
Free chlorine measurement, CHLOR PURE dosing



2. **Redox probe** for ASIN AQUA Home Pro Redox  
Measurement of redox potential, CHLOR PURE dosing



3. **Time dosing** without probe for ASIN AQUA Home Pro OXY  
Timebased dosing of OXY PURE in ml/m<sup>3</sup>/day  
Timebased dosing of Chlorine in ml/m<sup>3</sup>/h (only in case of probe failure)

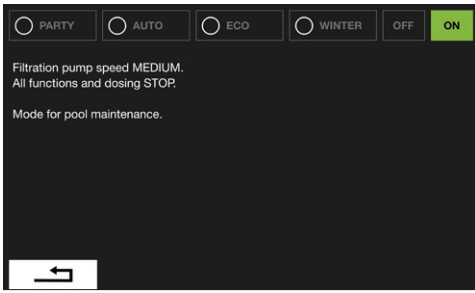

# Commissioning procedure and required value setting

## Commissioning procedure

The water in the pool must be clean without any additives especially free of cyanuric acid.

Ideally fill the pool with fresh water from the water main.

- Set the system to **MODE ON** - filtration NONSTOP 24 hours
- If you control with the CLF probe, set the disinfection to 0.0 mg/l.  
If you control with the REDOX probe, set the disinfection to 000 mV.  
If you have the Time dosing set the required value to 0 ml/m<sup>3</sup>/day or 0 ml/m<sup>3</sup>/h.

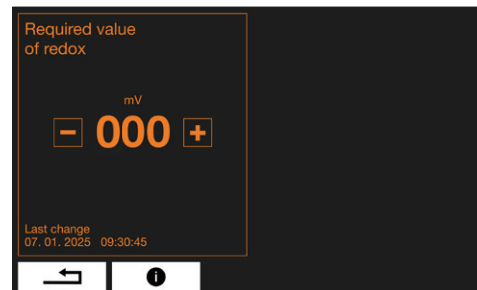
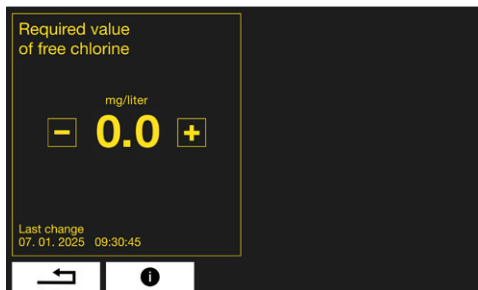
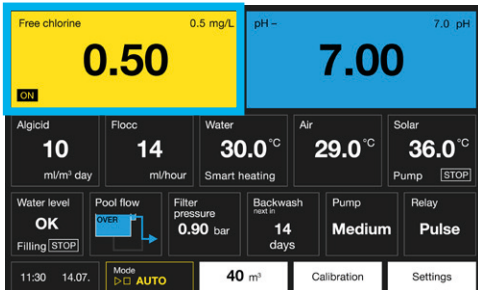

**CLOSE**



## Close the water supply to the probes

ASIN AQUA Home Pro displays no flow to the probes.



SuperCHLOR  
#13120

## Perform shock chlorination

Perform shock chlorination of pool water with Super CHLOR (inorganic active chlorine without stabilizers).

Follow the instructions on the packaging (1 kg = 80 m<sup>3</sup>).

## Before opening the water supply to the probes

The water must be **clean** and the **chlorine concentration** measured by the digital tester must be between **0.3 and 1.2 mg/l**. If the **concentration is lower**, repeat shock chlorination. If the **concentration is higher**, wait till the chlorine concentration in the water drops down.

**OPEN**



## Open the water supply to the probes

Warning No flow to probes turns off automatically.

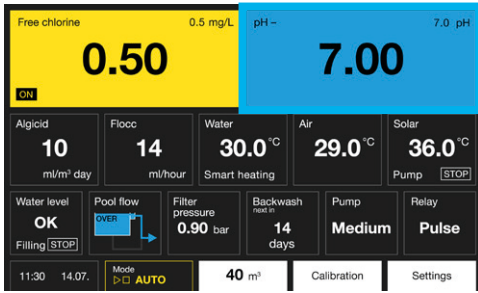

## pH setting

It is recommended to enter the required pH value equal to pH value of water you refill or slightly lower.

**Required pH value = refilled water pH value (in the range from 6.8 to 7.5)**

pH may change during operation but if it is in the range from 6.8 to 7.5 you do not have to change this setting.

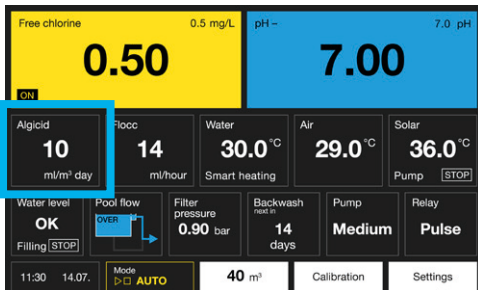
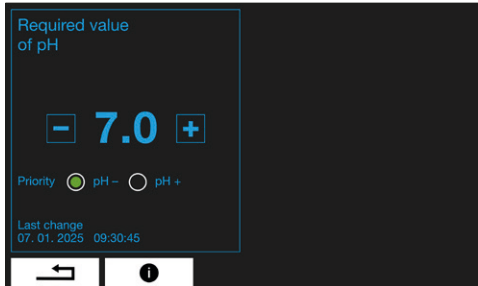

## ALGICIDE setting

A sufficiently effective dose for most pools is 10 ml/m<sup>3</sup> per day. If green algae appear in the pool, you can increase the dose. After algae have disappeared, the dose can be returned to 10 ml.

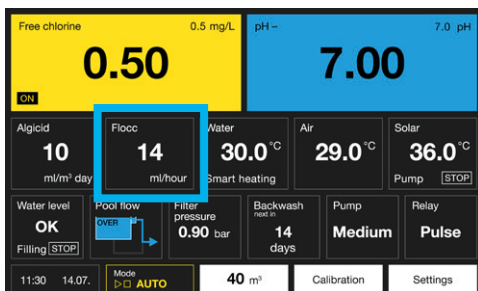
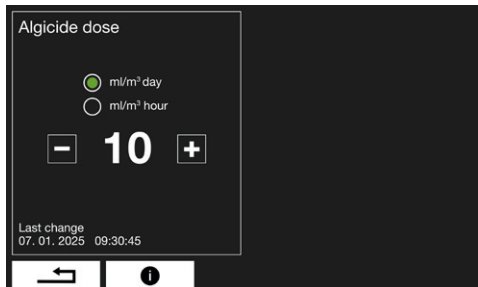

## FLOC+C setting

The FLOC+C dose is calculated from the amount of circulating water, which flows through the filtration. Based on your circulating pump power (in m<sup>3</sup>/h), adjust the FLOC + C dose value. E.g. with the circulation pump with power of 10 m<sup>3</sup>/h set the FLOC+C dose to 10 ml/h.

This value ranges from 10 to 40 ml per hour for most private pools.

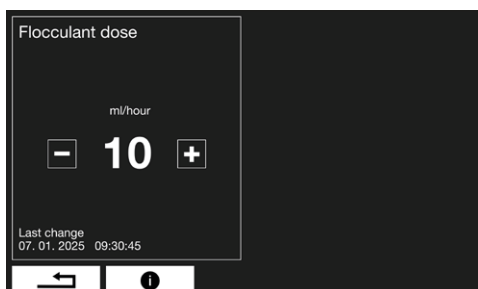

# If you have a CLF probe

The following conditions must be met for the CLF probe to function properly:

## pH of pool water

The ideal pH of pool water should be 6.8 to 7.5.

The pH value of the pool water must be stable.

If the pH value fluctuates, the chlorine value in the pool water also changes.

Chlorine content mg/l	Water temperature
0.3 to 0.5	24 to 26 °C
0.5 to 0.8	26 to 32 °C
0.8 to 1	Over 32 °C

## WARNING

Before proceeding to setting of the required values, or after replacing the electrolyte, keep the probe connected to the water for at least 1 hour, ideal 24 hours, to stabilize its measurement.

## Required chlorine value

The table shows the recommended chlorine levels in pool water. The required chlorine content varies with the temperature of your pool water and should never be lower than 0.3 mg/l.

## Procedure for setting the required chlorine value

Use a photometer to measure the chlorine value in a sample of the pool water.

**If the required chlorine concentration in the pool water (measured with a photometer) is:**

- **EQUAL** to the value on the ASIN AQUA display, your device is ready to maintain the chlorine in the pool.
- **LOWER** than the value on the ASIN AQUA display, increase the required value by 0.1 to 0.2 mg/l (regardless of the required value according to the table) compared to the current disinfection setting.

After mixing the pool and stabilizing the value on the ASIN AQUA display, repeat the measurement.

Repeat the procedure until the chlorine concentration in the pool water corresponds to the displayed value or is slightly higher, then set the correct required value according to the table. You can then calibrate the CLF probe (see the Calibration of the CLF probe section).

- **HIGHER** than the desired value on the ASIN AQUA display, you can calibrate the CLF probe (see the Calibrating the CLF probe section). Measured value should not be higher than 50 %.

## WARNING:

Resolve low chlorine levels in the pool water by increasing the required disinfection value.

## RECOMMENDATION:

Check the chlorine content of the pool water regularly a photometer or tester.

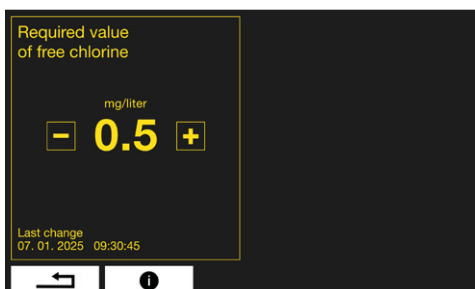

# If you have a Redox probe

For the REDOX probe to work properly, the following conditions must be met:

## pH of pool water

The ideal pH of pool water should be 6.8 to 7.5.

The pH value of the pool water must be stable.

If the pH value fluctuates, the Redox value in the pool water also changes.

Chlorine content mg/l	Water temperature
0.3 to 0.5	24 to 26 °C
0.5 to 0.8	26 to 32 °C
0.8 to 1	Over 32 °C

## WARNING

Before proceeding to setting of the required values, keep the probe connected to the water for at least 1 hour, ideal 24 hours, to stabilize its measurement.

## Required chlorine value

The table shows the recommended chlorine levels in pool water. The required chlorine content varies with the temperature of your pool water and should never be lower than 0.3 mg/l.

## Procedure for setting the desired Redox value

Set the desired REDOX value to 650 mV.

Use the tester to check that the chlorine content in the pool water is between 0.5 and 1.2 mg/l.

## Wait 24 hours for the probe to stabilize.

## Fine-tuning

Use a photometer to measure the chlorine value in a sample of pool water.

- If the chlorine value in the pool water is **IN DESIRED RANGE**, your ASIN AQUA is ready to maintain the desired chlorine concentration in the pool water.
- If the chlorine value in the pool water is **LOW**, increase the the desired REDOX mV value in the menu.
- If the chlorine value in the pool water is **HIGH**, decrease the the desired REDOX mV value in the menu.

**Every 10 mV corresponds to approximately 0.1 mg/l of chlorine in the pool water.**

### EXAMPLE:

The chlorine value in the pool water is 0.3 mg/l, the value shown on the display is 650 mV. If you want to have a chlorine value of 0.5 mg/l, you must increase the set redox value by 20 mV to 670 mV.

### NOTE:

The relationship between the redox potential and the chlorine content in the pool water cannot be determined using a precise table. The correct redox value must be determined by repeated photometric measurements.

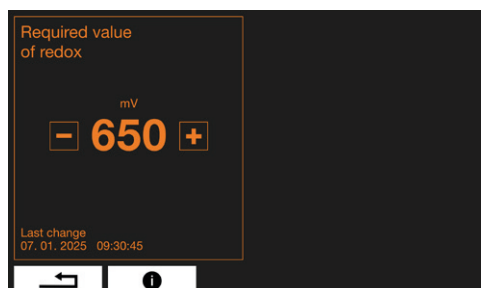

# If you have OXYGEN technology

## OXY PURE Setting

A sufficiently effective dose for most pools is 10 ml/m<sup>3</sup> per day. After several days in operation, measure OXYPURE concentration using the hand tester and change the dose, if required.

## Configuration

### Date and time

To ensure the correct function of timers, set the current date and time. Enter this menu by clicking on the date on the home screen or through the settings.

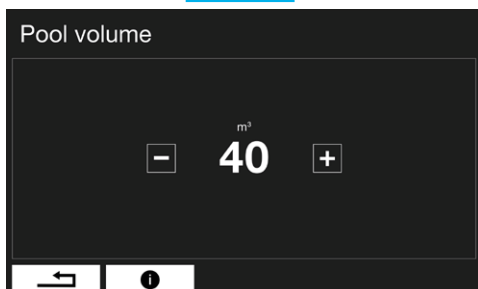
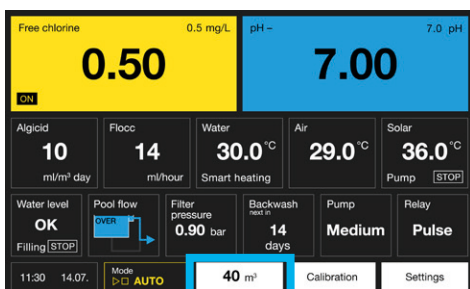
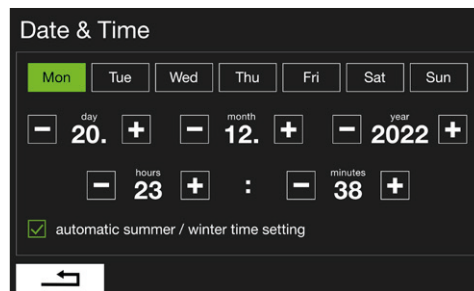
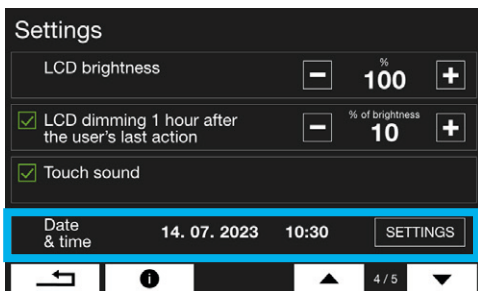
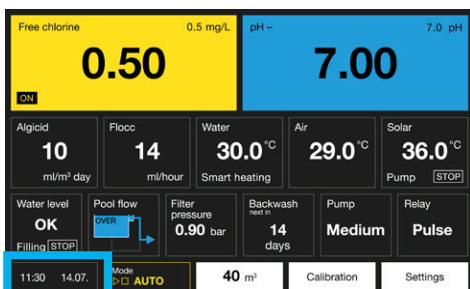

### Pool volume

To ensure the correct function of ASIN AQUA Home Pro, enter the correct volume of your pool. Enter this menu by clicking on the volume in the middle of the home screen.

Calculate your pool volume in m<sup>3</sup>:

Length (L) times width (W) times depth (D) is volume (V) - (L × W × D = V).

Enter the value using + and - buttons.

**WARNING:** The pool volume has effect on the dosing algorithm and maximum safe dose, enter the value correctly.

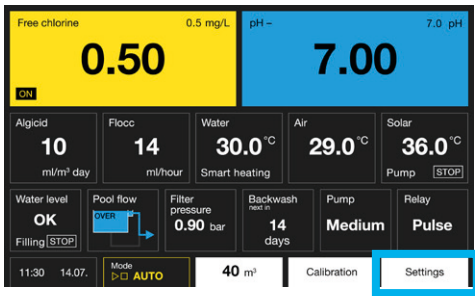

# Settings

## Language

Choose one of available languages.

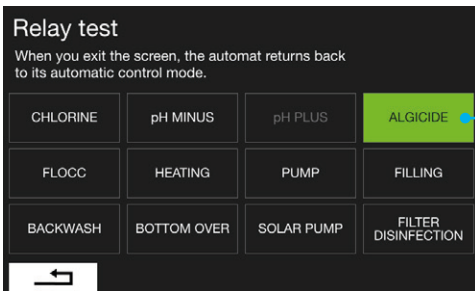
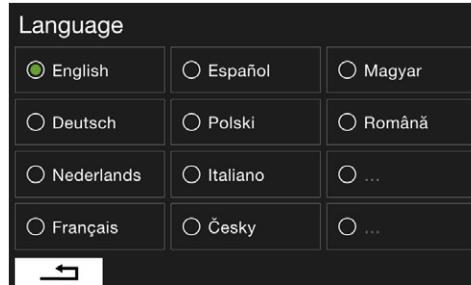
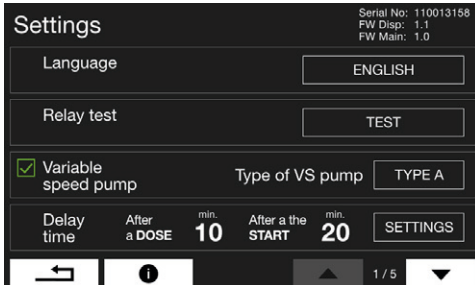

## Relay test

Test of the installation.

Press to **TURN ON (GREEN)** and press again to **TURN OFF**.

**DON'T FORGET! After you complete the test, stop all accessories in the menu. Do not dose in this step!**

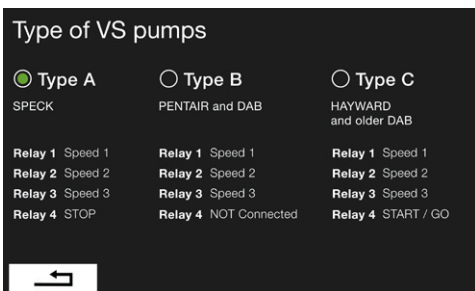

## Variable speed pump

Activate the function in the settings, and in the VS pump menu select the type of your variable speed pump.

Individual speeds are set directly on the pump according to the pump manufacturer's manual.

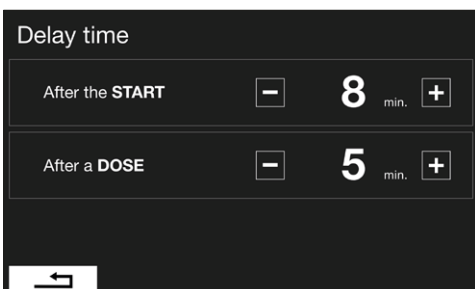

## Delay

**Delay time after start** of the filtration pump (upon timer switching ON) is time after start for which ASIN AQUA Home Pro does not take any action and waits for stabilization of a signal from probes.

**Delay time after dose** is time for which ASIN AQUA Home Pro does not dose and wait for the response of probes. The average response time is 4 to 10 min.

# Safety functions

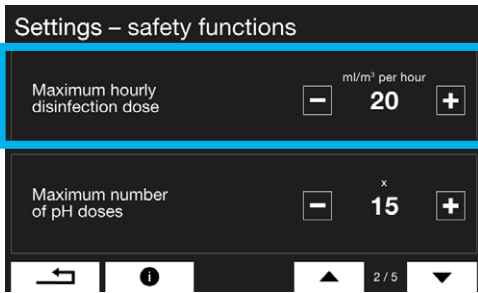

## Maximum hourly disinfection dose

Overdose protection.

We recommend leaving the factory value of 20 ml per m<sup>3</sup> per hour.

For whirlpool it is recommended to increase this value.

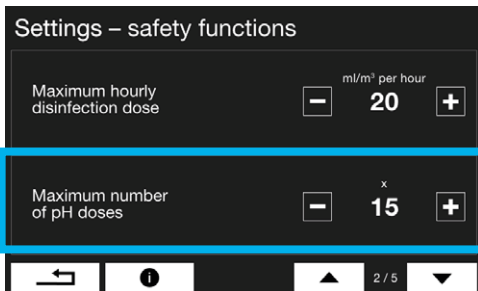

## Maximum number of pH doses - without probe response

If the measured pH value does not change after the preset maximum number of doses (according to the settings), ASIN AQUA Home Pro stops pH dosing and an error message appears on the display. Other ASIN AQUA Home Pro functions are not limited.

The error message must be canceled manually.

In case of hard water, it is necessary to increase the maximum pH dose limit.

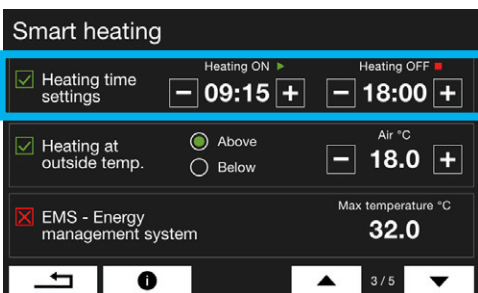

# Smart heating

## Heating time settings

This function allows to set a time for which the heating will be in operation.

The heat pump has higher efficiency during the day when outdoor temperature is higher.

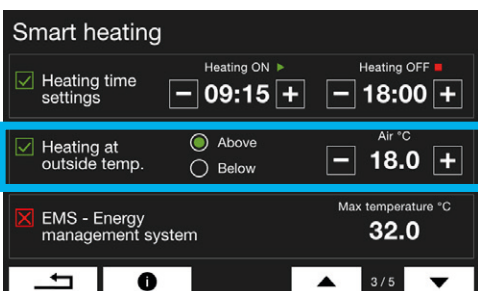

## Heating at outdoor temperature (above or below)

This feature allows to set the outdoor air temperature, at which or below which ASIN AQUA Home Pro starts heating. To use this feature, an outdoor air thermometer must be installed.

### Above

This function is used to optimize the efficiency of heat pump, which is higher with higher air temperature.

### Below

When using the solar heating and the heat pump simultaneously, the below gives an option to automatically deactivate the heat pump and prioritize the solar heating which optimizes electric consumption.

- Check the BELOW option. Set the temperature between 30 and 40. When the temperature drops below the set value, the heat pump starts heating. When it rises above the set value, the heat pump stops, and heating is done only through the solar panel.

**NOTE:** Other heating functions can be set individually for each mode in the **MODE Settings** (ref. to the chapter MODE settings).

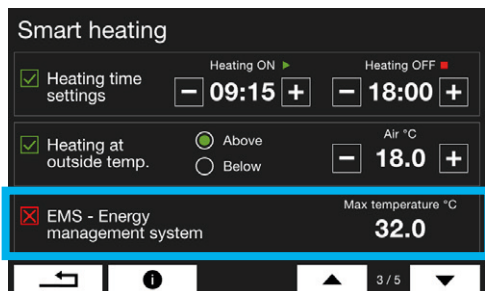

## EMS - Energy management system

This feature allows the efficient use of surplus energy generated by a home solar power plant to heat and filter pool water. Once activated, the device will monitor the incoming signal from the photovoltaic system and, upon detection, automatically start the pool's heating and filtration system.

**Outside the filtration period:** The circulation pump automatically starts at speed 1 and the heat pump is activated at the same time. The heat pump will remain in operation for at least 1 hour to prevent excessive switching and to prolong its life.

**During the filtration period:** The heat pump is activated automatically, regardless of whether the target temperature has already been reached.

## Additional settings

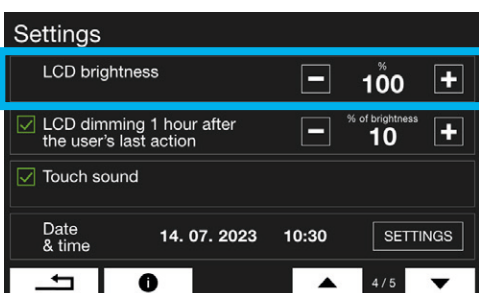

### LCD brightness

Set the LCD brightness.

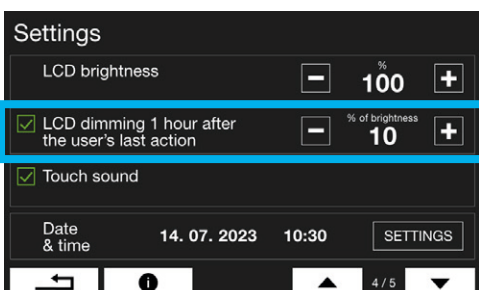

### LCD dimming

If enabled, after 60 minutes without interaction ASIN AQUA Home Pro will reduce the brightness of the screen.

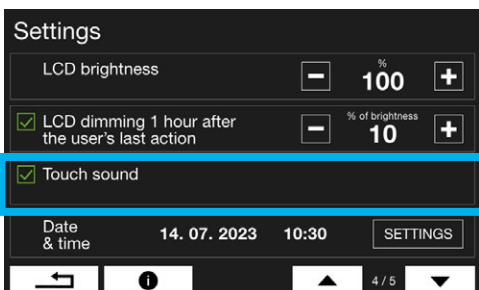

### Touch sound

If enabled, every touch on the touchscreen will make a sound.

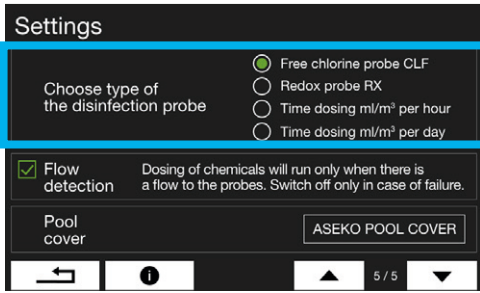

## Choose the type of the disinfection probe

Choose the probe which controls the dosing of disinfection.

Free chlorine probe - direct measurement of free chlorine concentration in ppm

Redox probe - oxidation-reduction potential (ORP) measurement in mV

ml/m<sup>3</sup>/hour - without probe, time based dosing of liquid chlorine

ml/m<sup>3</sup>/day - without probe, time based dosing of oxygen technology

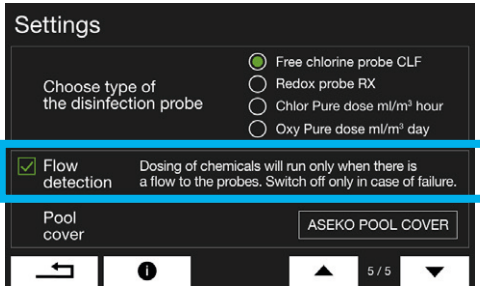

## Flow detection

The flow detector detects flow of measured water. Dosing of chemicals will take action only if the water flow to probes is detected to prevent dosing in standing water.

Wash the strainer on the measuring water filter on a regular basis.

**Warning:** Only switch off the flow detection in case of Flow detector failure.

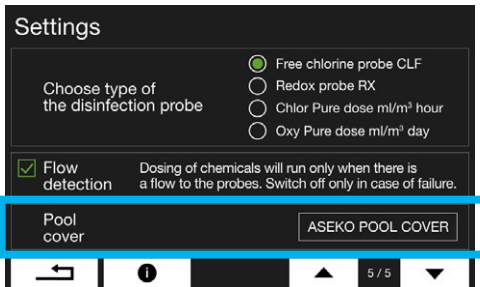

## Pool Cover position detection

If the pool cover is closed during the filtration time set by the timer, the VS pump will change the speed to the Speed 1 (LOW).

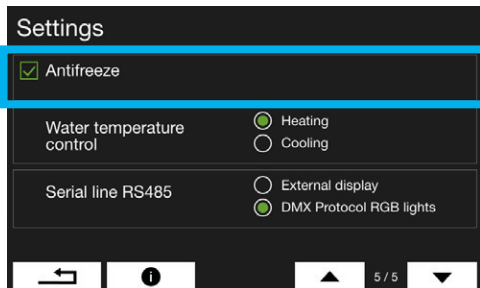
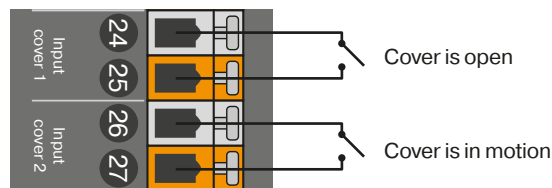

## Antifreeze

Function to help reduce the risk of water freezing in the pool system. When the outdoor temperature drops below 0°C, the circulation pump is automatically activated to keep the water moving.

This function runs alongside the current mode and does not override its settings. It does not guarantee full protection in extreme cold conditions.

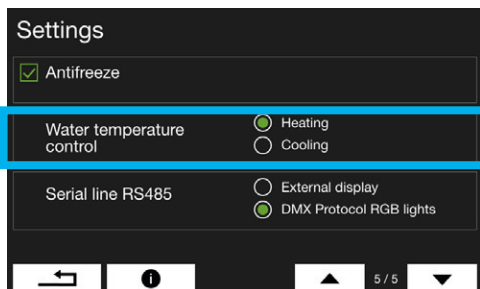

## Heating / Cooling

Allows switching between heating and cooling operation by reversing the control logic.

For example If cooling is active, the target water temperature is 30°C and the actual temperature is 32°C, the relay is activated to start cooling.

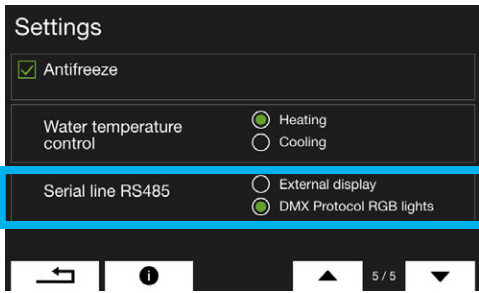

## DMX Protocol RGB Lights

In the menu of the device, select the Serial line RS485 to be in DMX Protocol RGB lights mode (more info in chapter RGB lights).

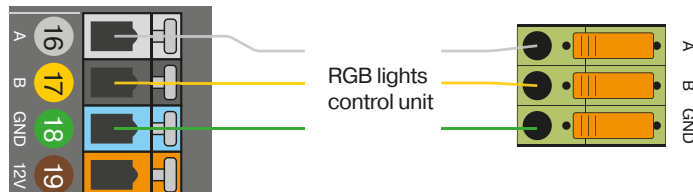

## Mode settings

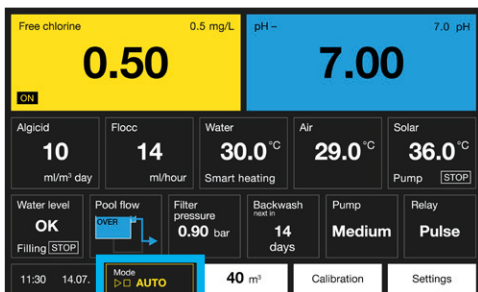

Automate your pool with 6 adjustable modes.

**Party | Auto | Eco | Winter | Off | On**

Change modes through ASIN AQUA Home Pro screen, external touchscreen, or smartphone app Pool REMOTE.

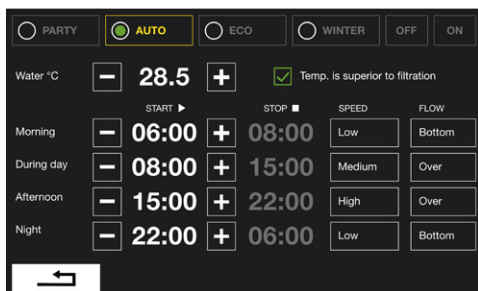

### AUTO

The Auto mode for regular use of the pool. It uses all functions in a balanced way to achieve comfort and economic operation.

Set the filtration times: **morning | during day | afternoon | night** and desired temperature. For each filtration time set the pool water flow, and the speed of the circulation pump.

#### Temperature is superior to the filtration timer

Enabling this function will keep both the heating and the circulation pump operational until the desired water temperature is reached.

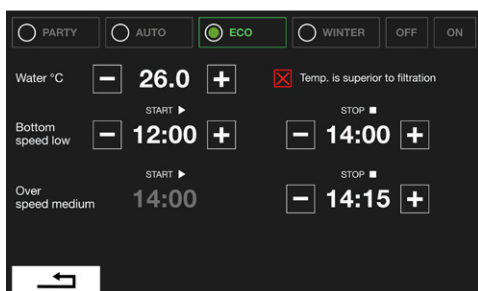

### ECO

The ECO mode is designed to operate the swimming pool in your absence or when you want to operate economically. Keeps the pool ready for a switch to normal operation.

Allows to set the desired temperature, the pool water flow, the speed of the circulation pump, and one filtration time.

There is always a 15-minute overflow filtration at the end of each period to prevent greening of the buffer tank.

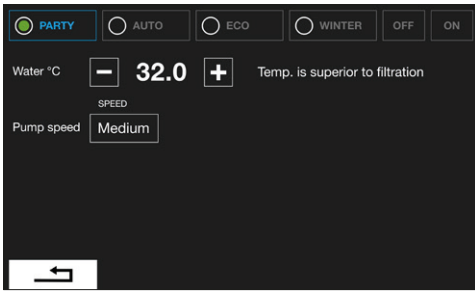

## PARTY

This mode switches ON the circulating pump on preset speed and heating to the required temperature.

**This mode has no time functions. To switch OFF the circulation pump and the heating change the mode.**

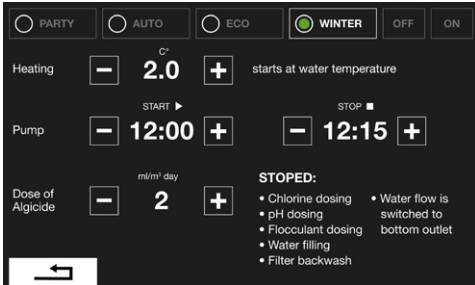

## WINTER

Activating this function set the device into the special Winter mode. This mode prevents the pool water from freezing and keeps the water clean with dosing of algicide. **In the Winter mode following function are deactivated:** chlorine dosing, pH dosing, flocculant dosing, water filling, filter backwash.

**Water flow is set to the bottom drain.**

Every day the filtration pump runs in preset filtration timer.

Outside of the filtration timer the filtration pump remains OFF but is automatically activated for the period of 15 minutes when the outdoor temperature drops below 0 °C.

- If, after this period, the water temperature is under the required value (0 - 6 °C), the filtration pump stays ON, and the heating is activated until the water temperature exceeds 2 °C.
- If, after this period, the water temperature is higher than the required value (0 - 6 °C), the circulation pump is turned OFF.

If the outdoor temperature stays below 0 °C this cycle is repeated every 6 hours.

When using the Winter mode without the **outdoor air thermometer**, the system acts as it always detects 0 °C outdoor temperature.

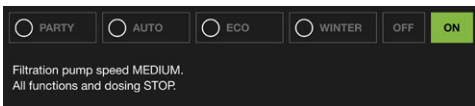

## ON

The filtration runs NONSTOP. The heating is OFF.

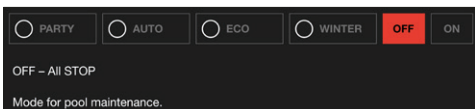

## OFF

Everything is OFF.

# Functions

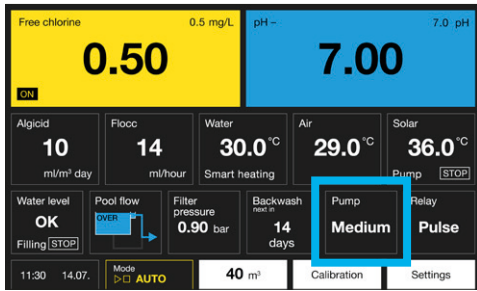

## Pump

The field displays the current speed of the filtration pump.

Press the field to go to the settings of the current mode.

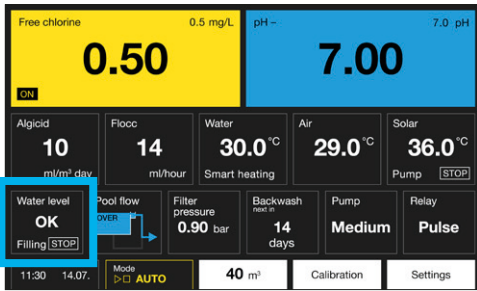

## Hydrostatic pressure water level sensor - level monitoring and automatic refilling

The water level is monitored using a pressure-type level sensor, which is easy installed by inserting the probe into the buffer tank or the blind nozzle of skimmer pools. Water level is measured in centimeters. ASIN AQUA monitors four different levels, which can be set in centimeters in the water level meter menu.

### Setting:

#### High level ALARM - too much water in buffer tank

After this level is reached, following actions may start:

1. If the automatic filter backwash is enabled, one backwash cycle starts and drains the waste water.
2. If the automatic filter backwash is not enabled, the relay switches on (filter backwash) for the period of time until level is OK. The second circulating pump or automatic drain valve can be connected to this relay.

#### Refilling OFF - required level

Refilling stops

#### Refilling ON - level at which refilling starts

Refilling starts when the water level stays for at least 10 seconds below this value (in order to prevent oscillating).

#### Low level ALARM

Circulation (filtration) pump shuts off.

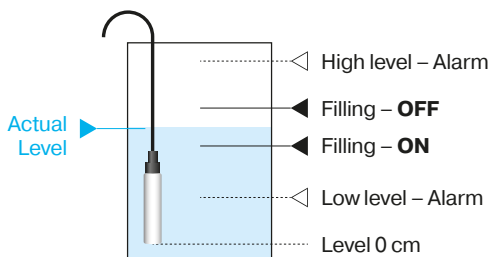
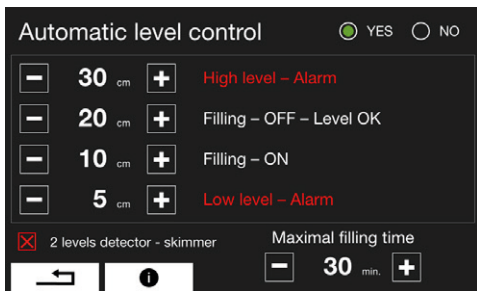

## Float switch

With the skimmer water level detector #13366 (float switch), the water level is monitored in two levels.

**Filling - OFF** required level reached. Refilling stops.

**Filling - ON** level at which refilling starts. Refilling starts if the water level stays for 10 seconds below this value to prevent oscillating.

## Maximum Refilling Time

Maximum time to reach the required water level. If the water level is not reached within the preset maximum refilling time an error message appears.

Set the maximum filling time to 0 to disable the maximal filling time function.

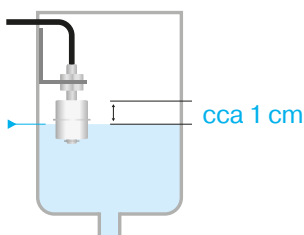

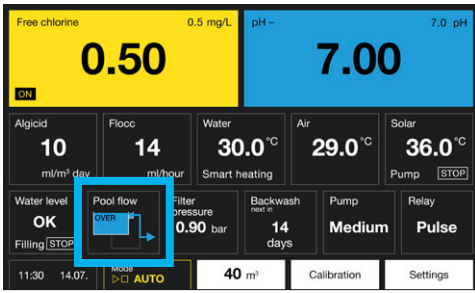

# Functions

## Switch Overflow/Bottom drain – Besgo 3w

The box shows the current direction of water flow to the filtration.

Enable this function to change the direction of the water flow.

This change will be valid until the next timer event.

During filter backwash, water flows through the BOTTOM DRAIN.

An alarm WATER LEVEL TOO HIGH switches the water flow to the OVERFLOW until the alarm expires.

The pool cover has no effect on the BOTTOM/OVERFLOW switching.

**The three-way BESGO should be connected in a way that when the solenoid valve is not powered, water flows through the BOTTOM.**

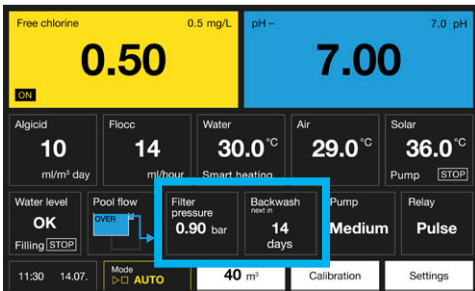
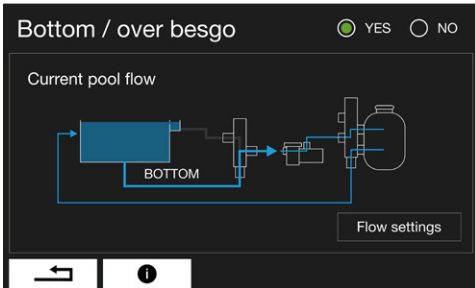

## Automatic filter backwash

The ASIN AQUA technology is in particular based on the high efficiency of filtering and removing even the finest impurities, it is necessary to **wash the filter on a regular basis**. The automatic filter backwashing function ensures the filter washing on a regular basis in the preselected intervals.

**To enable this function, it is necessary to use the automatic 5-way BESGO valve.** The ASIN AQUA controls the BESGO valve with relay output.

When the relay switches ON, the BESGO valve switches to the required position with the pressure of water or air and performs the filter backwash. See the BESGO manual.

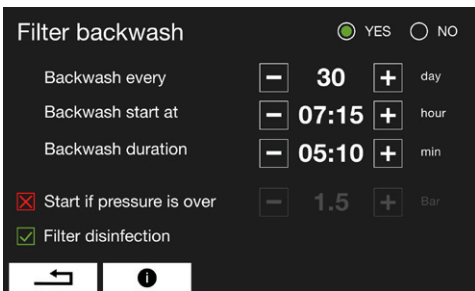

## Backwash by pressure

The ASIN AQUA Home Pro offers an additional feature for automatic backwashing based on the pressure in the filter. If the pressure exceeds the preset value, the device will automatically initiate a backwashing cycle. In practice, this means the device performs backwashing according to the settings on the previous screen and executes an additional backwashing cycle if the pressure in the filter increases beyond the set threshold. To enable this feature, a pressure gauge must be installed on the filter.

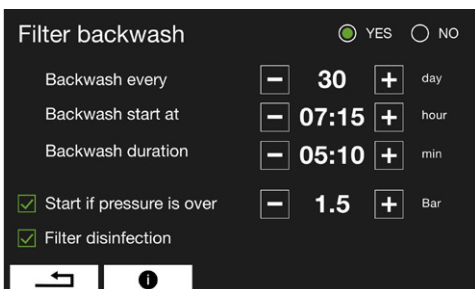

## Filter disinfection

An optional PP60 pump can be connected to the filter disinfection output. This pump activates automatically during the backwash cycle to ensure thorough sanitization of the filter using liquid chlorine. The filter is completely disinfected, and no additional chlorine enters the pool, as the chlorinated water is discharged to waste during backwash.

# Functions

## Solar

Menu shows the solar settings.

Activate this function and set the required temperature for the solar panels. Once the required temperature of the solar panels is reached, the solar relay will activate. The solar relay can control the Besgo 4-way or the solar panel circulation pump.

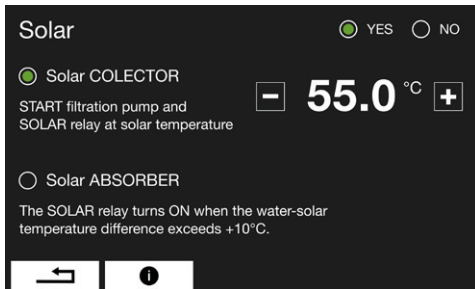
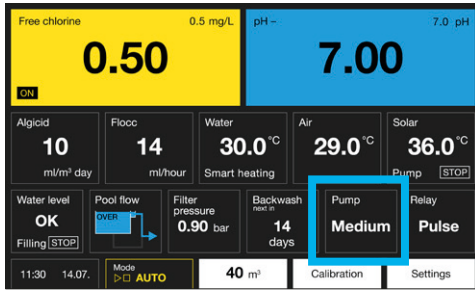

## Relays

ASIN AQUA Home Pro has one integrated programmable relay to control one extra accessory. It is also possible to connect optional **RL module** (relay module) to connect 4 extra relays.

Integrated relay has a only week timer function and can be set and controlled directly on the ASIN AQUA Home Pro screen or via the Pool REMOTE app.

Extra relays from the RL module have functions: Week timer, Countdown and ON / OFF. Extra relays can be set and controlled only via the Pool REMOTE app.

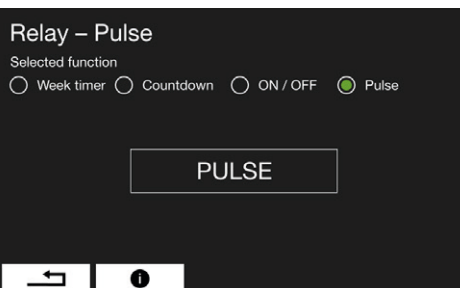
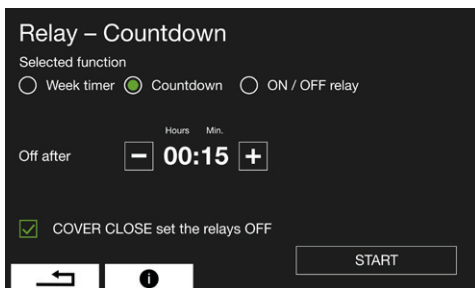
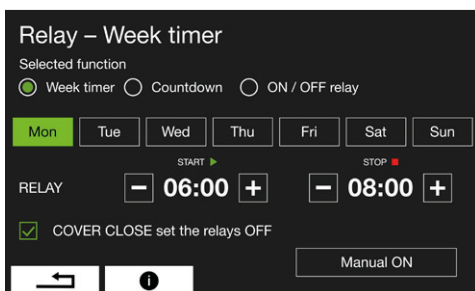
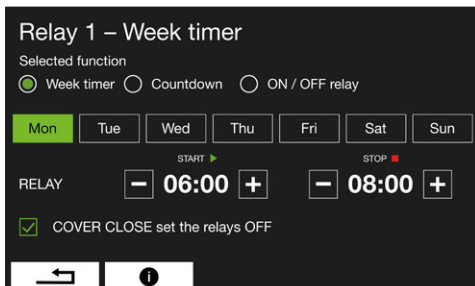
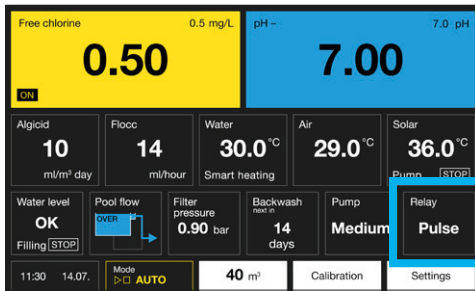

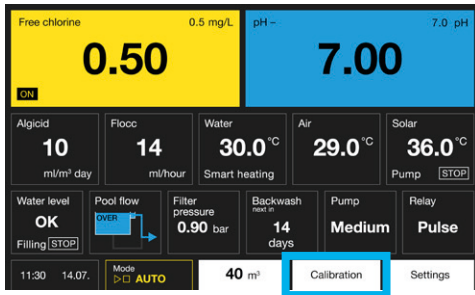

## In operation measurement and calibration

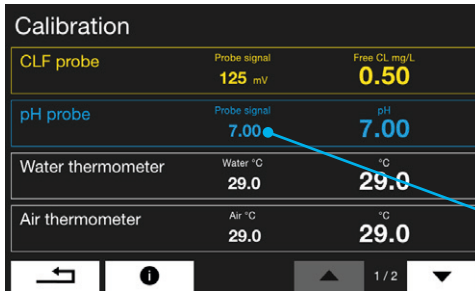

### pH probe calibration

When pH is being measured in operation, there may be a difference between the value measured by ASIN AQUA and the actual pH value in water.

Proceed to the calibration.

### pH probe calibration menu

#### Non-calibrated value

The pH probe calibration menu always displays the original non-calibrated value. Calibration of the pH probe is not possible when the new value differs by more than 1 from the non-calibrated value. If the difference from the non-calibrated value exceeds 1, the probe should be sent for inspection or replaced with a new one.

**Calibration is not possible when the new value differs by more than 1 from the non-calibrated value.**

**The pH probe can only be calibrated in the pH range of 6.2 to 7.8.**

**The pH probe cannot be calibrated when the LOW or HIGH warning is displayed.**

### pH probe calibration process

Calibration can be done in two ways:

#### 1. With a buffer

- **Close the water supply to the probes.**
- Remove the probe from ASIN AQUA Home Pro :  
rinse the probe with clean water and wipe it.
- The probe must remain connected to the device via the cable. Dip the probe in the calibration buffer and after the value displayed on ASIN AQUA is stable, enter the buffer value into the pH Probe Calibration menu.

#### 2. With a colorimeter or Pool Tester

- **The water supply to the probes must be open**
- Measure the pH value directly in pool water using a colorimeter or Pool Tester.
- Then enter this value into the pH Probe Calibration menu. Calibration can be performed in the range of 6.4-7.8.

pH 7.00 Buffer #12065



Digital Photometer  
Aseko #13449



# In operation measurement and calibration

Calibration		
CLF probe	Probe signal 125 mV	Free CL mg/L 0.50
pH probe	Probe signal 7.00	pH 7.00
Water thermometer	Water °C 29.0	°C 29.0
Air thermometer	Air °C 29.0	°C 29.0

## CLF probe calibration

Do not calibrate the probe until the pool water is thoroughly mixed and the value displayed on the ASIN AQUA Home Pro is stable. After adding fresh electrolyte, it takes at least 4 hours for the signal to stabilize.

Perform calibration only when there is stable pH value.

Perform calibration of the CLF probe when the manually measured value of free chlorine is equal to or higher than the value you want to have in your pool.



Digital Photometer  
Aseko #13449

Calibration is performed by entering the manually measured value of chlorine concentration (using a photometer) in the CLF probe calibration menu.

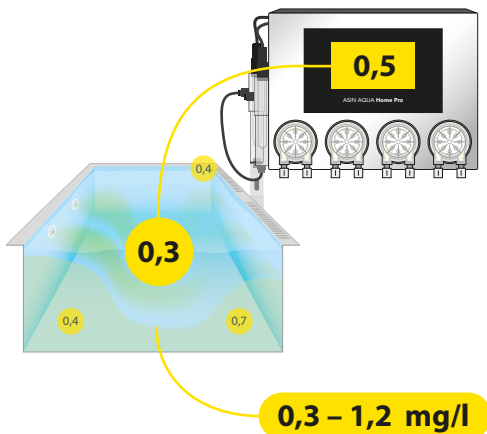

Calibration **is not necessary** if the difference between the photometer measured value and the value shown on the display **is less than 0.2 mg/l**.

Calibration is best performed with chlorine concentrations in the pool water in the range of **0.3 - 1.2 mg/l**.

### Calibration restrictions

The CLF probe cannot be calibrated if the output signal is less than **20 mV**.

The CLF probe can only be calibrated in the CL range from **0.3 to 5.0 mg/l**.

# In operation measurement and calibration

Calibration		
CLF probe	Probe signal 125 mV	Free CL, mg/L 0.50
CLT probe	Probe signal 125 mV	Free CL, mg/L 0.50
REDOX probe	Probe signal 125 mV	Free CL, mg/L 0.50
pH probe	Probe signal 7.00	pH 7.00

Redox Buffer 650mV  
#12091



## Redox probe calibration

### Use a buffer

- **Close the water supply to the probes.**
- Remove the probe from ASIN AQUA Home Pro: rinse the probe with clean water and wipe it with a paper towel.
- The probe must remain connected to the device via the cable during the calibration. Dip the probe in the calibration buffer and after the value displayed on ASIN AQUA Home Pro is stable, enter the buffer value into the Redox probe calibration menu.

**RECOMMENDATION:** Perform the calibration using the 650 mV buffer. If the non-calibrated value differs by 50 mV from the buffer, it indicates that the probe is faulty.

Calibration		
Water thermometer	Water °C 29.0	°C 29.0
Air thermometer	Air °C 29.0	°C 29.0
Solar thermometer	Temp. °C 53.0	°C 53.0
Filter flow meter	Signal m <sup>3</sup> /h 11.5	Flow m <sup>3</sup> /h 11.5

## Water thermometer calibration

If the temperature of water in the pool is different from the temperature shown on ASIN AQUA Home Pro, calibrate the water thermometer in the water thermometer calibration menu.

## Outdoor air thermometer calibration

If the temperature of air is different from the temperature shown on ASIN AQUA Home Pro, calibrate the air thermometer in the air thermometer calibration menu.

## Solar thermometer calibration

If the temperature of solar is different from the temperature shown on ASIN AQUA, calibrate the solar thermometer in the solar thermometer calibration menu.

#12177 OX tester



## Adjustment of OXPURE active oxygen dose

When using chlorine-free technology ASIN AQUA HOME OXY the optimum OXPURE concentration value is from **50 to 100 mg**.

From time to time check this value by measuring with the OX tester and adjust the dose in the menu, if required.

# Stabilizer in water



## Cyanuric acid

The value of Cyanuric acid must be **0 ppm**. Cyanuric acid greatly diminish the effectiveness of chlorine, making it difficult to accurately measure and control its concentration.

### **Never use stabilizers with cyanuric acid in ASIN AQUA devices**

#### **The value of Cyanuric acid must be 0 ppm!**

Cyanuric acid forms a chlorine-cyanurate complex, which rapidly decreases the disinfecting power of chlorine and makes it impossible to measure with a free chlorine probe. Be aware that some chlorine tablets contain cyanuric acid. Ensure there is no cyanuric acid in your pool.

# Maintenance

Replacement hose for the pump PP 60  
#12073

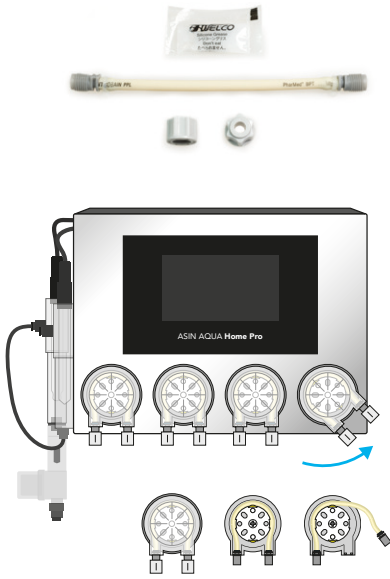

To ensure the optimum efficiency, perform visual checks and maintenance of ASIN AQUA on a regular basis.

## PP60 and PP10 tube replacement

To prevent the pump from failing, it is recommended to replace the tube #12073 every 24 months for private and every 12 months for public pools.

### In doing so, proceed as follows:

- Switch off ASIN AQUA.
- Turn the pump cover cassette anticlockwise and take it out.
- Release both tube ends and take it out of the cassette.
- Lubricate the new tube with the supplied grease.
- Insert the lubricated tube into the cassette.
- Place the cassette back on the pump and turn it clockwise to lock it.
- Use new nuts, which are part of the replacement tube set, for connection of the PE tube.

Injection valve #12005



Replacement rubber band for injection  
valve #13087



## Injection valve maintenance

On a regular basis, check throughput of the injection valves, rubber band integrity, remove scale.

In case of private pools, replace injection valve rubber bands #13087 every 2 years. In case of public pools, replace #12005 every year.

Flow detector #12106



## Flow detector with filter

Rinse the filter of the flow detector regularly.

## Fuse Replacement

Fuse T 1 A #13079  
or Fuse T 6.3 A #13099



### T 6.3 A

Fuse protecting the inner electronics. In case of its burnout, check the inner electronics.

### T 1 A fuse

Fuse protecting external sensors. In case of burnout of this fuse, check the level sensor, flow detector, and external display.

pH - Buffer 7,00 #12065



## pH probe testing

The pH probe can be declared functional if it meets the following criteria:

- it is not visibly mechanically damaged
- If the difference between the non-calibrated reading and the reference value exceeds  $\pm 1.0$  pH, the probe is considered faulty.

Example: the pH of the water is 7.2 and the probe measures 7.9 the tolerance is 0.7, which is less than the permitted 1.0 the probe is OK

- the probe reacts to positive and negative changes in the pH of the water or buffer

**Example:** if we insert a probe with a clean tip into a buffer with a pH of 7.0, the probe must respond to 90% of the range within 1 minute.

## CLF probe testing

At a free chlorine concentration of 0.8 mg/l, the normal signal output from the free chlorine probe should be approximately 80 mV. If the signal at this concentration is lower than 30 mV, it suggests that there may be an issue either with the water quality or with the probe itself. In such cases, please consult the CLF probe manual and follow the recommended troubleshooting procedures to verify the probe's performance.

Test using clean water that has been left to stand for 24 hours, ensuring it is free of chlorine. In this scenario, the signal should not be above 10 mV. If the signal exceeds this value, the probe may be faulty.

Redox Buffer 650 mV #12091



## REDOX probe testing

The Redox probe can be declared functional if it meets the following criteria:

- it is not visibly mechanically damaged
- The redox probe ages naturally, so its sensitivity decreases, but it should never fall below a certain limit. The permissible deviation is 50 mV; when tested with a buffer of 650 mV, it should not show less than a minimum of 600 mV
- the probe reacts to both positive and negative changes in the free chlorine content of the water

**No manufacturer of pH and redox probes provides a warranty. However, ASEKO has decided to provide its customers with a two-year warranty on probes purchased together with the device, during which you are entitled to free repair of probes if they show deviations greater than those specified above.**

# Winterizing - storage during winter

If you want to operate ASIN AQUA in Winter mode, go to the chapter Configuration - Winter mode. If you do not want to operate the device in Winter mode, it is necessary to winterize the device and all its components (store them when not in use).

## Winterization of the unit and its accessories

If you do not want to have the ASIN AQUA device in operation in winter, the device and all accessories must be dismantled, winterized and moved to a suitable location. To disassemble and winterize the ASIN AQUA, follow the instructions below.

### Storing of pool chemicals, connecting PE tube and dosing pumps

- If the chemicals are left in a place where the temperature does not drop below 0°C, turn OFF the ASIN AQUA. Disconnect the dosing pumps from the ASIN AQUA and remove the inner tube from the pump. Leave the tube connected to the connecting PE tube. Put the pump cartridges without the inner tubes back onto the ASIN AQUA. Store the chemical barrels and connecting PE tube in a place where the temperature is between +0 - +40 °C.
- If chemicals remain in a location where the temperature drops below 0°C, SWITCH OFF ASIN AQUA. Remove the connecting PE tubes from the chemical barrels and place them in a container with water. Turn on ASIN AQUA. Go to the RELAYTEST menu and press Chlor/Oxypure, pH, Algicide and Floc. When the connecting PE tube is completely filled with water, turn OFF the relay test. Remove the water container and perform the RELAYTEST again to completely fill the connecting PE tube with air. When the connecting PE tube is completely filled with air, stop the relay test and turn OFF the ASIN AQUA. Disconnect the connecting PE tubes from the dosing pumps and from the injection valves. Store the chemical barrels in a place where the temperature is between +0 - +40 °C.

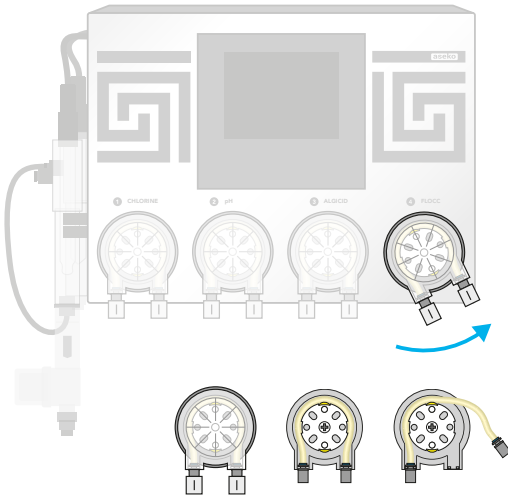

### Disconnect of the ASIN AQUA and its accessories

1. Disconnect the ASIN AQUA Home mains cable from the 230 V / 50 Hz socket.
2. Disconnect the filter unit's mains cable from the ASIN AQUA and store the filtration pump according to manufacturers manual.
3. Disconnect all accessories from the ASIN AQUA motherboard and store them according to manufacturers manual.

#12154 Probe storing sump



#12082 Probe storing liquid



## Winterizing of probes

### Winterizing of pH and Redox probe

Remove the probe from the housing, dry it with a paper towel and place it in a storage sump filled with a special storage liquid. See probes manual at the website [manuals.asekopool.com](http://manuals.asekopool.com).

### Winterizing of CLF probe

Remove the probe from the housing, unscrew the membrane and empty the electrolyte from it. Do not put the membrane back on the probe and store them separately in a dust-free place where the temperature is between +5 - +40 °C and the humidity does not exceed 70 % throughout the winter. See probes manual at the website [manuals.asekopool.com](http://manuals.asekopool.com).

## Storing of the unit

Move the ASIN AQUA unit in a place where the temperature is between +5 - +40 °C and the humidity does not exceed 70 %.

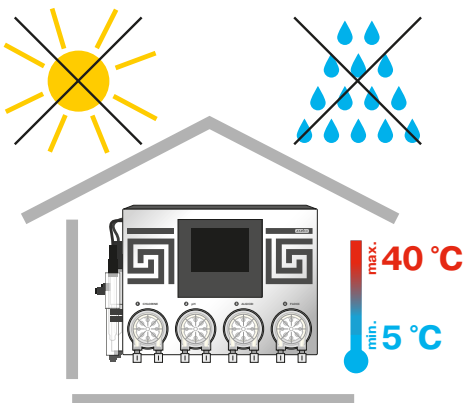

# Internet connection

The LAN connector is to be connected to the domestic router. Data are sent in the intervals of 10 seconds to the address **aseko.cloud**, the route must not be blocked by the firewall.

If you are not able to setup the connection by your own ask your IT specialist for help.

## Possible connection methods

### Home network

Connect the ASIN AQUA Home Pro to your router via LAN cable.

### Mobile network

In case you have no direct internet access you can use the data transmission over the mobile network. Connect the ASIN AQUA Home Pro to your mobile network router via LAN cable.

### Wifi connection

If you install the ASIN AQUA Home Pro in place where is no access to your private network by wired connection but your Wifi has enough signal, you can connect the ASIN AQUA Home Pro to your Wifi by use of Wifi extender.

### Powerline via 230V/DC

If you have no wired access to your LAN network but your ASIN AQUA Home Pro is in the at the same electric network you can connect the LAN network via 230 V power line socket adapter.

#### **If you have connection problems:**

If you experience connection problems, you can find a step-by-step guide called AA-Internet\_Connections-Man in the Internet connection folder at [manuals.asekopool.com](http://manuals.asekopool.com).



**Connect ASIN AQUA Home Pro via the LAN cabel**

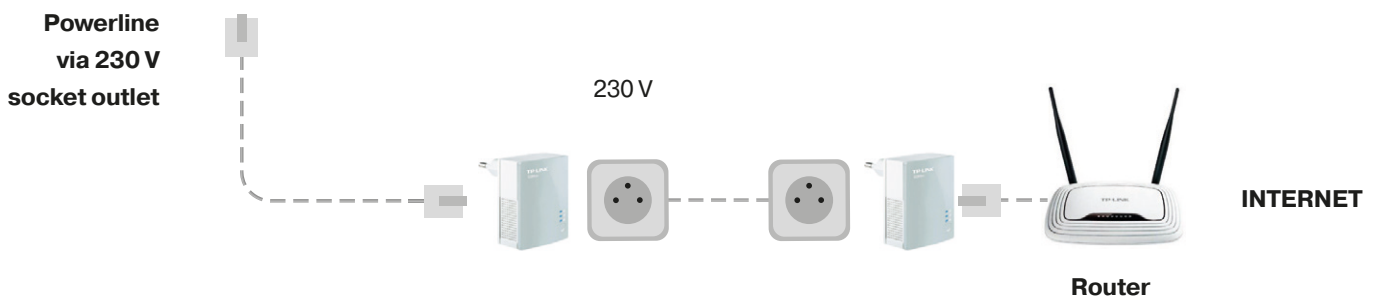
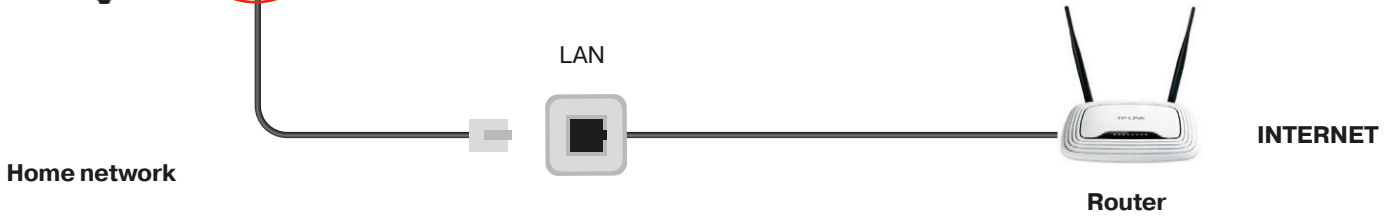

# Aseko Live app



- Clear monitoring of water quality, temperature, and equipment status
- Chemical consumption tracking
- automatic alerts for low chemical levels, exceeded measurement limits (chlorine, pH), and device errors or malfunctions
- Remote monitoring – access your pool data anytime, anywhere
- Aseko Live app available for iOS and Android

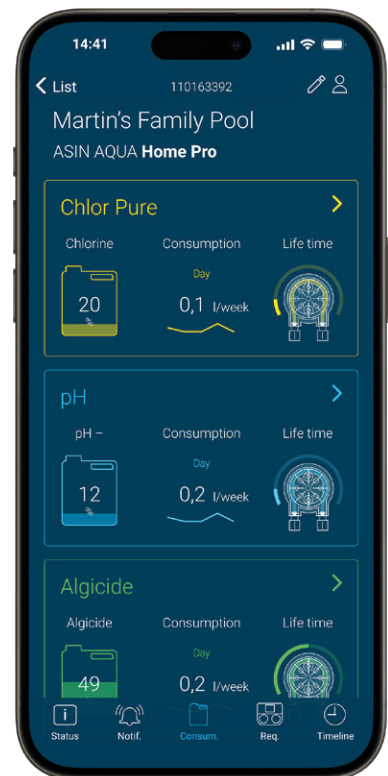
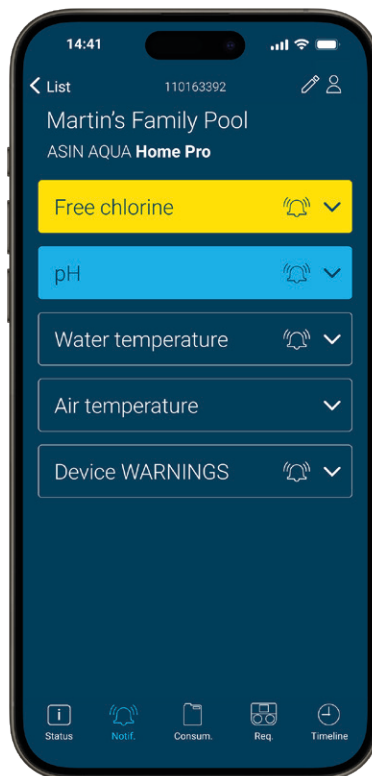

Aseko Live  
for iOS



Aseko Live  
for Android



# <https://aseko.cloud>

- Web application with a clear, intuitive interface for monitoring pool water quality
- monitoring of water quality, temperature, and equipment status,
- chemical consumption tracking,
- automatic alerts for low chemical levels, exceeded measurement limits (chlorine, pH), and device errors or malfunctions
- Detailed, professional charts visualizing current conditions and 30-day history. Ideal for technicians and public pool operators – enables trend analysis, correlation insights, and efficient remote diagnostics
- Data export for hygiene and regulatory documentation in professional pool operations
- Easy integration into superior control systems and smart homes via an open API

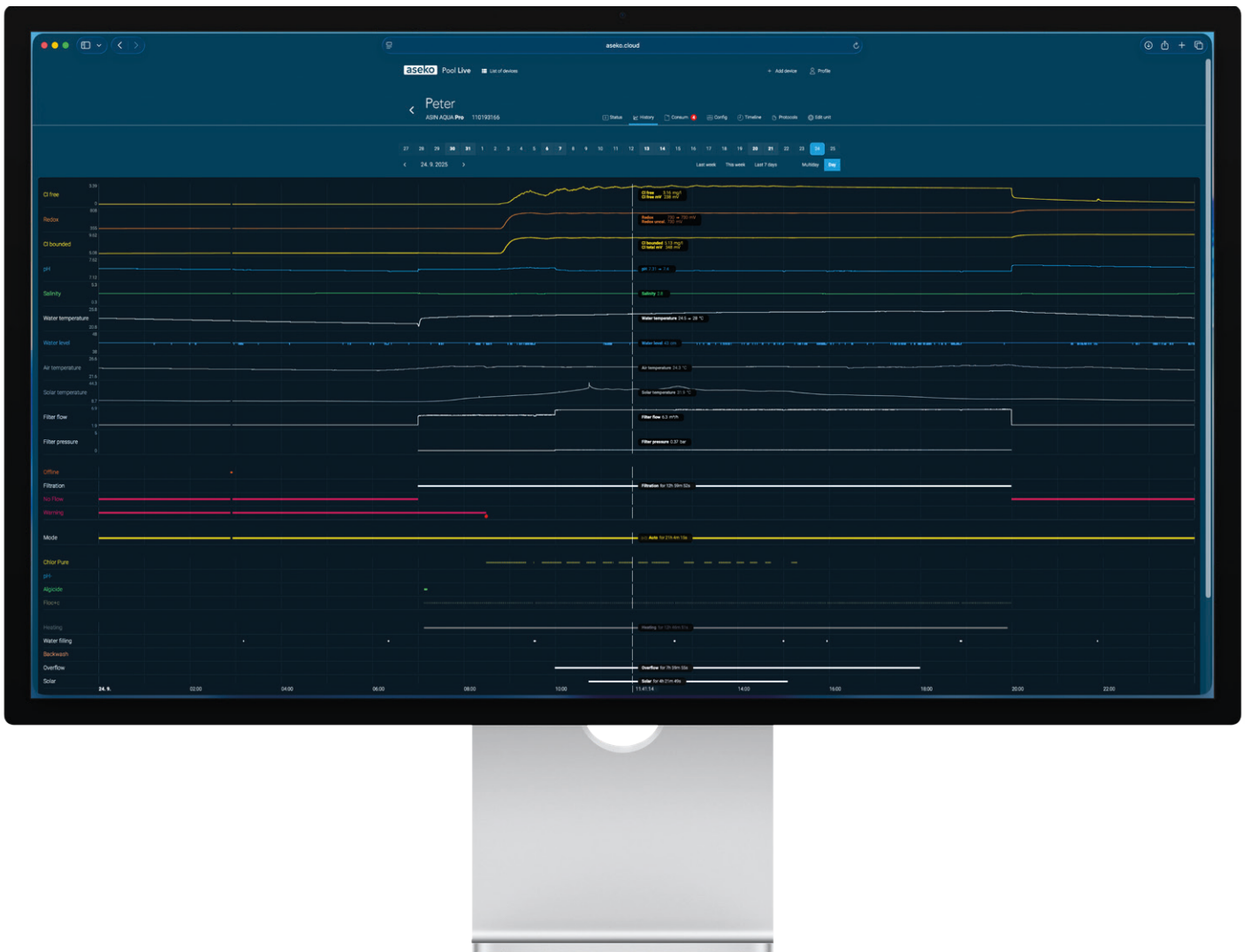

# Aseko Remote App



- Aseko Remote app for advanced remote control of pool technology
- Switching between intuitive preset modes (Auto, Eco, Party, On and OFF)
- Adjust filtration timer settings directly from your smartphone
- Control water flow direction – choose between overflow or bottom drain
- Set pump speed and optimize performance according to pool use
- Enables remote control of up to five connected components (e.g., lights, cover, water features)
- Supports remote filter backwash start for easy maintenance
- Invite process for easy sharing of remote control
- Aseko Remote app available for iOS and Android

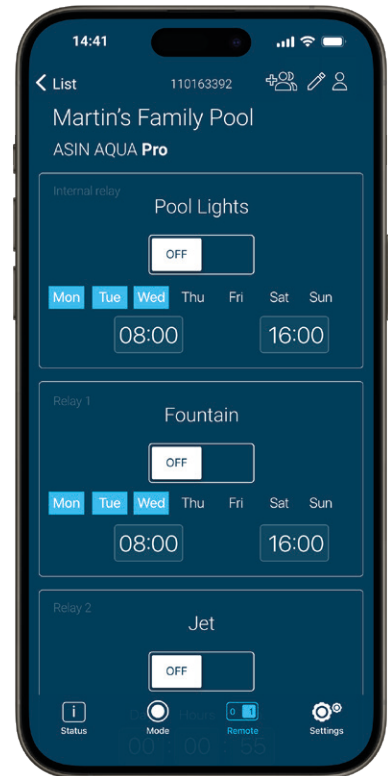
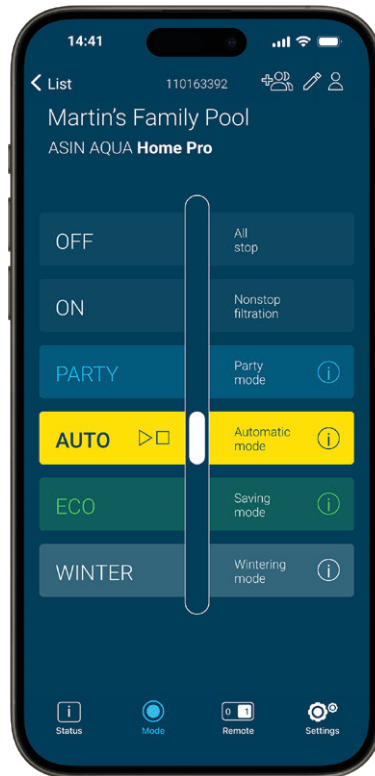

Aseko Remote  
for iOS



Aseko Remote  
for Android



## Create your account

Create your account at [account.aseko.cloud](https://account.aseko.cloud) or use your existing Aseko Live account.

## Enter serial number

Enter the serial number of your ASIN AQUA Home Pro to add the unit under your account.

## Overview

The screen provides all the important information about the current status of your pool and the connected components controlled by ASIN AQUA Home Pro.

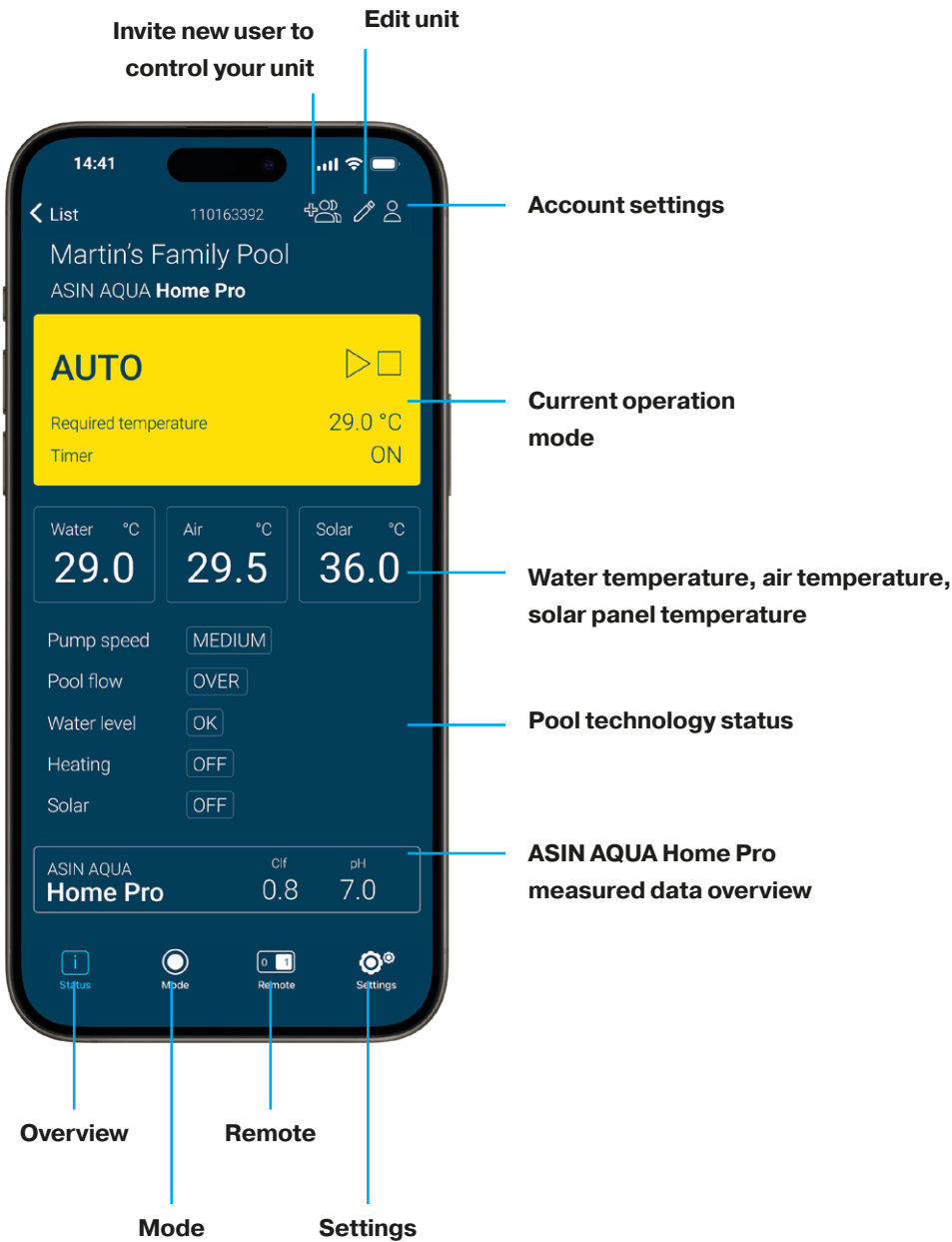

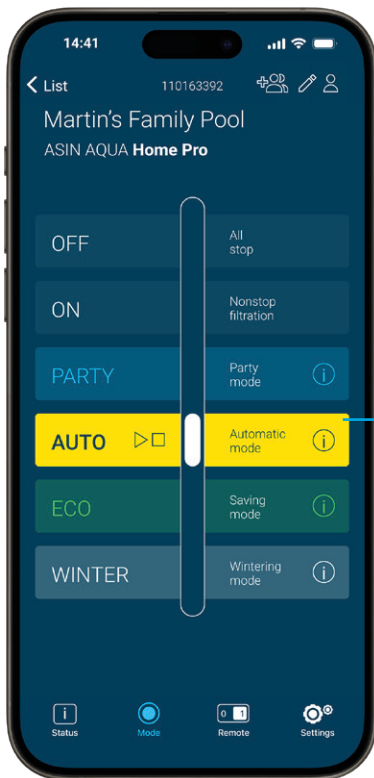

## Mode selection

The screen serves to switch between operation modes of your pool controlled via ASIN Pool.

The slider serves to control your pool operation modes.

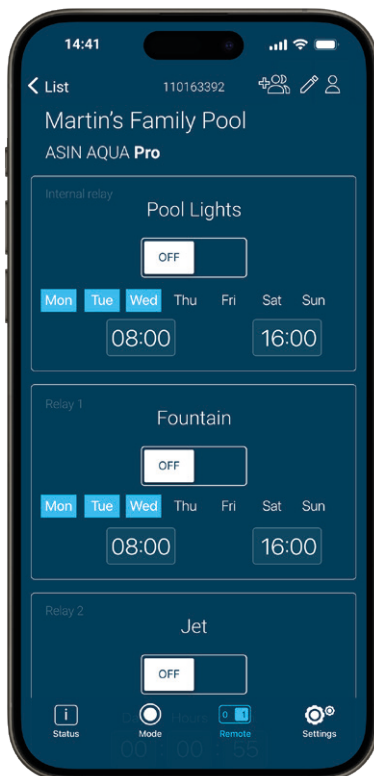

## Remote control

Customize the functionality of each relay in the settings tab. Control relays manually by turning them ON or OFF, send pulses, or configuring them as week timers to automatically operate your pool equipment at specific times of the day.

**Warning: The pulse relay feature can be used to remotely open a close a pool cover. Note that remote control of pool covers is prohibited in certain countries due to safety regulations. It is your responsibility to ensure compliance with the laws and safety standards of your country regarding the use of remotely controlled pool covers. Always prioritize safety and follow all local guidelines and regulations.**

## Relay extension module

Number of relays can be extended from 1 to 5 using a RL module #13065.

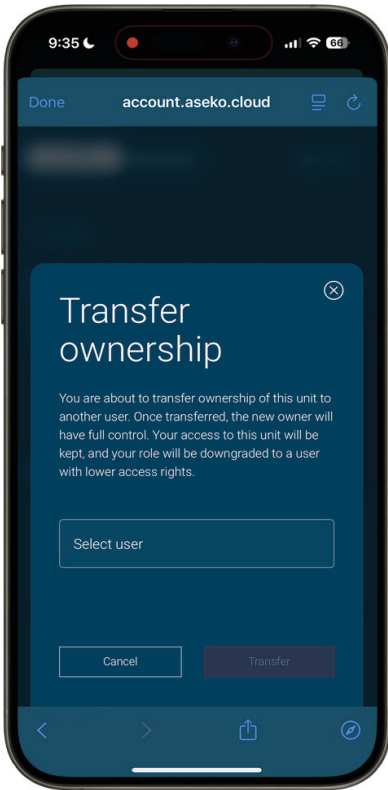

## Transfer of ownership

Open the unit detail and select the option to invite a new user. Then click on Edit users, which will open a browser window with the unit details. In this window, use the Transfer of ownership button to open a dialog box, where you enter the email address of the user to whom you want to transfer ownership. New owner has to be existing and invited user of your unit. You will also need to choose a new role for yourself, which will replace your current role as the owner. Once these details are filled in, simply confirm the transfer to complete the process.

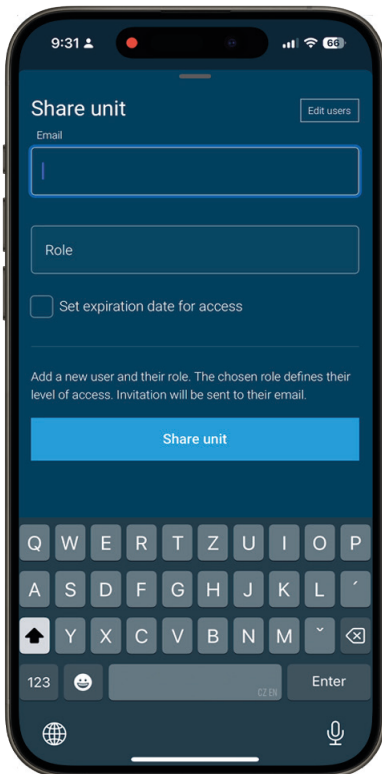

## Invite New User

Click the Invite New User icon to open a dialog where you can enter the email address of the person you want to invite. Assign one of the available roles and optionally set an access expiration date. After the expiration, access will be automatically revoked.

Role management can be done in the Account Settings under the Unit Details section. You can quickly access it from the invitation dialog via the Edit Users button.

## Roles

**Owner** – Full access to the unit, including settings and sharing. Only one owner per unit. Ownership changes can be done only through transfer of ownership.

**Admin** – Can operate the unit, change settings, and share access. Multiple admins are allowed.

**Technician** – Can operate and change settings but cannot share access.

**User** – Can operate the unit only; cannot change settings or share access.

**Viewer** – Read-only access for remote support. Cannot operate, change settings, or share access.

# Warnings

**Maximum hourly disinfection dose**

20 ml/m<sup>3</sup> per hour exceeded without reaching the target value.

- Out of reagent
- The dose dispenser pump fails to dispense
- Injection valve blocked
- Water not flowing to probes
- Probe failure

CLOSE

23:30 22.12.

## Maximum hourly disinfection dose

If the maximum hourly dose of disinfection is exceeded with no probe response, ASIN AQUA Home Pro stops dose dispensation and displays a warning.

Recommended settings:

Pool	15 – 20
Whirlpool	20 – 50
Whirlpool high stress	30 – 99

**The measured value did not change after 15 doses of pH**

- Out of reagent
- The dose dispenser pump fails to dispense
- Injection valve blocked
- Water not flowing to probes
- Probe failure

CLOSE

CLOSE

23:30 22.12.

## The measured value did not change after 15 doses of pH

If the maximum number of pH doses is exceeded with no probe response, ASIN AQUA Home Pro stops dose dispensation and displays a warning.

The present hardness affects the dose amount:

Soft water	< 9° dH	15 doses
Hard water	9 – 21° dH	30 doses

**Too rapid change of pH value**

ASIN Aqua stop regulations of pH for 2 hours for safety reasons.

CANCEL RESTRICTIONS

CLOSE

23:30 22.12.

## Too rapid change of pH value

Too rapid change of pH is usually caused by refilling water directly to the skimmer. If such rapid change of pH occur, ASIN AQUA Home Pro stops controlling pH for two hours.

This limitation can be manually disabled.

After pH has been stabilized or two hours have elapsed, ASIN AQUA Home Pro changes over to the normal mode.

**There is no flow to the probes**

ASIN AQUA PRO will not dispense doses until the flow of measured water is restored.

**RESTORE WATER FLOW TO PROBES!**

CLOSE

23:30 22.12.

## There is no flow to the probes

No flow to the probes was detected.

# Warnings

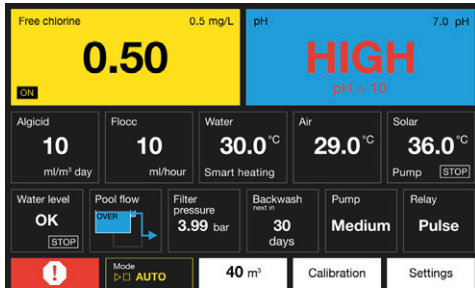

## The probe shows a pH > 10

Check the pool water and probe.

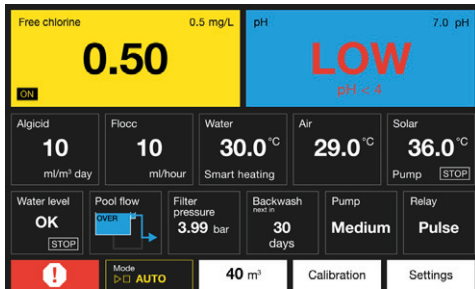

## The probe shows pH < 4

Check the pool water and probe.

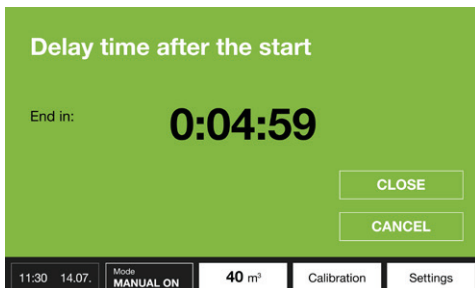

## Delay time after the start

Waiting for the pool water to mix after the start.

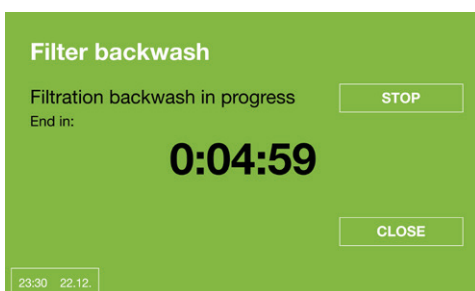

## Filter backwash

Filter backwash in progress.

External touch display  
#12048

# External touch display

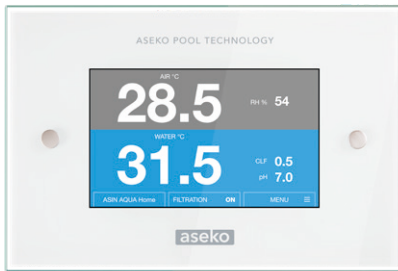

The external display shows

1. Pool water parameters:  
Temperature, pH value, redox potential or chlorine concentration.
2. Parameters of the air in the pool area:  
relative humidity and temperature.

The setpoints can be set on the ASIN AQUA Home Pro device and a probe calibration can be carried out via the external display.

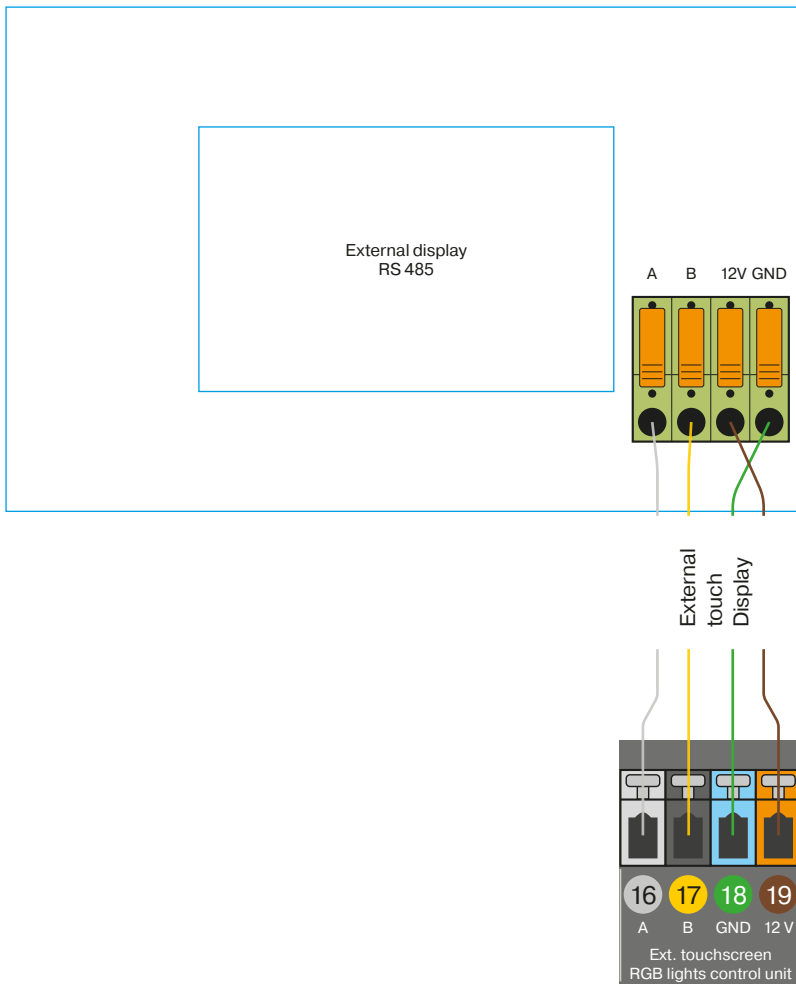

# RGB lights

The ASIN AQUA Home Pro supports the DMX protocol to connect and control RGB lights (Duravision,EVA, compatibility with other manufacturers has to be discussed with the seller).

## 1. Enable DMX protocol RGB lights in the menu of the device

In the menu of the device, select the Serial line RS485 to be in DMX Protocol RGB lights mode.

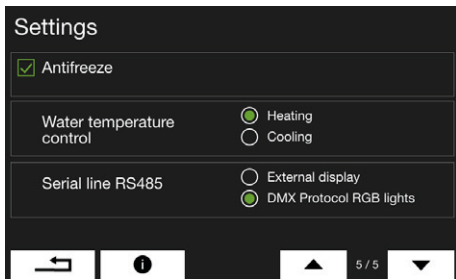

## 2. Connect light control unit with the RS485 output of ASIN AQUA Home Pro

Connect the RS485 of ASIN AQUA Home Pro with the DMX input on the motherboard of you light control unit according to the schem below.

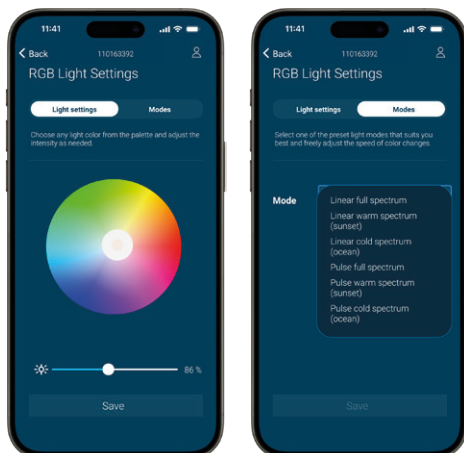

## 3. Open Aseko Remote app and to control the lights

RGB lights can only be controlled via Aseko Remote app. Select a color and save or use one of the preselected modes.

# Enhancement of filtering efficiency



## AFM® activated filter media

AFM is direct substitute for filter sand. It doubles efficiency of the existing filtration system. AFM® is resistant to biological pollution and formation of so-called bio-film.



## ZPM® coagulation mixer

ZPM increases effects of coagulation and flocculation for transition of smaller dissolved solids (turbidity) to larger particles that can be removed by filtering.

## ASEKO Pool & Spa FLOC+C

A unique mixture of coagulant and flocculant for increasing the efficiency of the filter. The coagulant neutralizes the zeta potential, which keeps impurities dispersed into a fine turbidity. The flocculant produces flakes that are better captured by the filter.

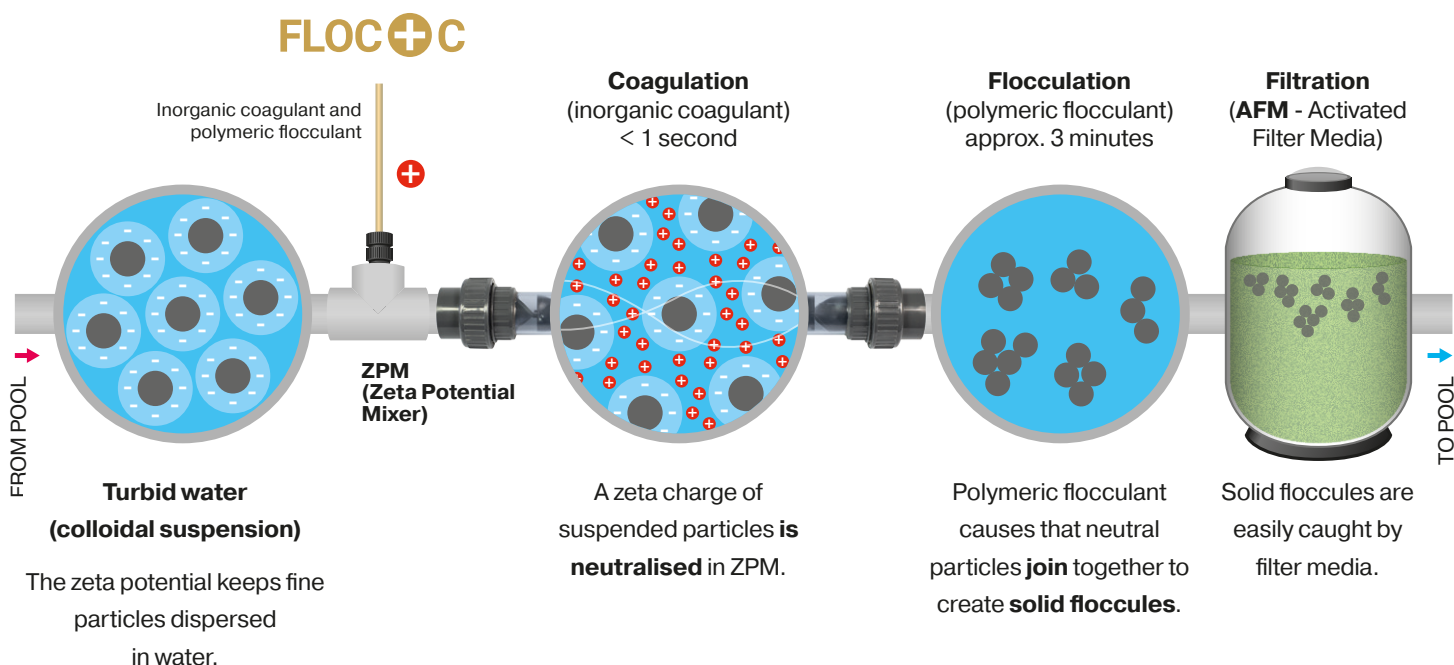





USER'S MANUAL

# ASIN AQUA **Home Pro**

2025

