

Robotic Pool Cleaner User Manual

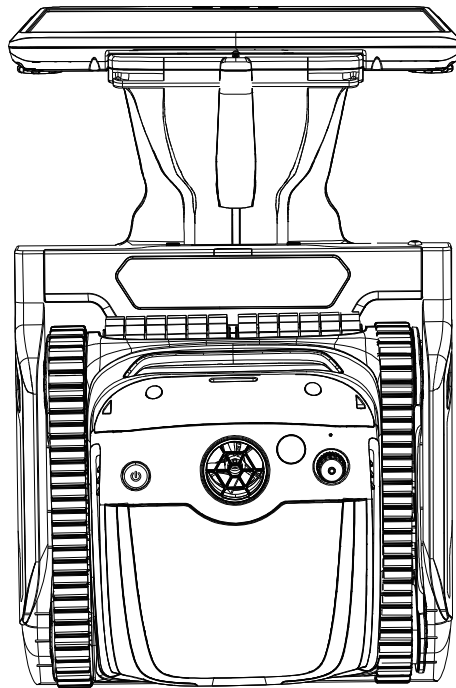

WYBOT S2 Solar

WYBOT®

Read through the entire manual before running your new robotic pool cleaner, and keep this manual handy for your reference.



Thank you for choosing WYBOT products, your support means a lot to us. Continuous providing the best solution to free you up from pool cleaning and enjoy your family time is always our pursuit.

WYBOT Robotic Pool Cleaner is dedicated to serving you high efficiency, low power consumption, easy operation and thorough pool cleaning work.

Its unique appearance and reliable functions as one-button activation, powerful suction and scrubbing, fine filtration, smart navigation, remote control, and high compatibility with various pool shapes and constructions materials assure you a convenient, intelligent, and optimal pool cleaning.

Feel free to contact us by Email or visit our website with any questions. We are very glad to hear your advice on our continuous improvement.

Safety Instructions

Warning

Read the manual carefully before you use the cleaner. Your safety is the most important thing. Please read through and operate the device as per instructions, WYBOTICS Co., Ltd. is not held liable for any loss or injury caused by improper use.

Failure to operate the device as per the warnings can result in serious injury, electrocution or death.

1. Use only the accessories recommended or sold by WYBOTICS Co., Ltd.
2. Use only the original and authorized charging station. Avoid charging any other types of devices with this station. Improper use may result in overheating or corrosive liquid leakage from the battery.
3. Cut off power supply when doing any maintenance or removing it from the pool.
4. In case of any abnormal operation from the charging station, cut off the power supply immediately, and remove the robotic cleaner from the station. Contact professionals at once.
5. Ensure the charging port is dry before plugging in the charger end.
6. Make sure the electrical outlet is protected by a ground fault circuit interrupter (GFCI) and an earth leakage interrupter (ELI).
7. Do not use a cord-damaged charger to avoid any electrical shock.
8. Do not try to use nonauthorized extension cord to connect the charger to the robot.
9. Never allow children to ride on the cleaner/docking station or play with it as a toy.
10. Do not allow child to operate or maintain the device or docking station.
11. Do not enter the pool when the robot is working in it.
12. Never expose or charge the device in flammable environments.
13. Only licensed professionals can disassemble the sealed parts of the robot.

Safety Instructions

Cautions

Failure to operate the device as per the cautions can cause a damage to the device.

1. Install the solar panel and docking station following the steps in the manual.
2. If the pool liners comes away or is damaged, please repair it before intall the docking station onto the wall.
3. Charge the unit before first use.
4. Do not over charge the cleaner, which will reduce the battery life.
5. Charge the cleaner prior to being stored for a long time (over 6 months) to maintain an optimal battery life.
6. Do not operate the cleaner while pool filter is running.
7. Remember to wash and clean the filter basket and ultra-fine filter after each use.
8. Store the cleaner in a cool and ventilated place, away from direct sunshine or any heat source.
9. No stepping onto the solar panel or putting pressure onto the surface.
10. Use only the pool cleaner in the following water conditions:

Chlorine	Max 4 mg/L
pH	7.0 - 7.8
Temperature	41 - 95 °F (5 - 35 °C)
NaCl	Maximum 5000 PPM

CONTENTS

01 / WYBOT AT A GLANCE	01
Product External Overview	01
Product Internal Overview	03
Packing List	04
02 / INSTALL SOLAR KIT	05
03 / HOOK UP DOCKING STATION	06
04 / GET STARTED	07
Charge your new WYBOT	07
Setup your new WYBOT	10
<i>Connect to your App</i>	10
<i>Choose your cleaning mode</i>	11
Run your new WYBOT	12
05 / DO A FILTER CLEANING	13
06 / PUT BACK TO DOCKING STATION	14
07 / DEVICE SPECIFICATION	15
08 / LIMITED WARRANTY	16
09 / HOW TO MAINTAIN YOUR DEVICE	16
10 / FAQ & TROUBLE SHOOTING	17
11 / CERTIFICATION	19
12 / WYBOT CUSTOMER CARE	19

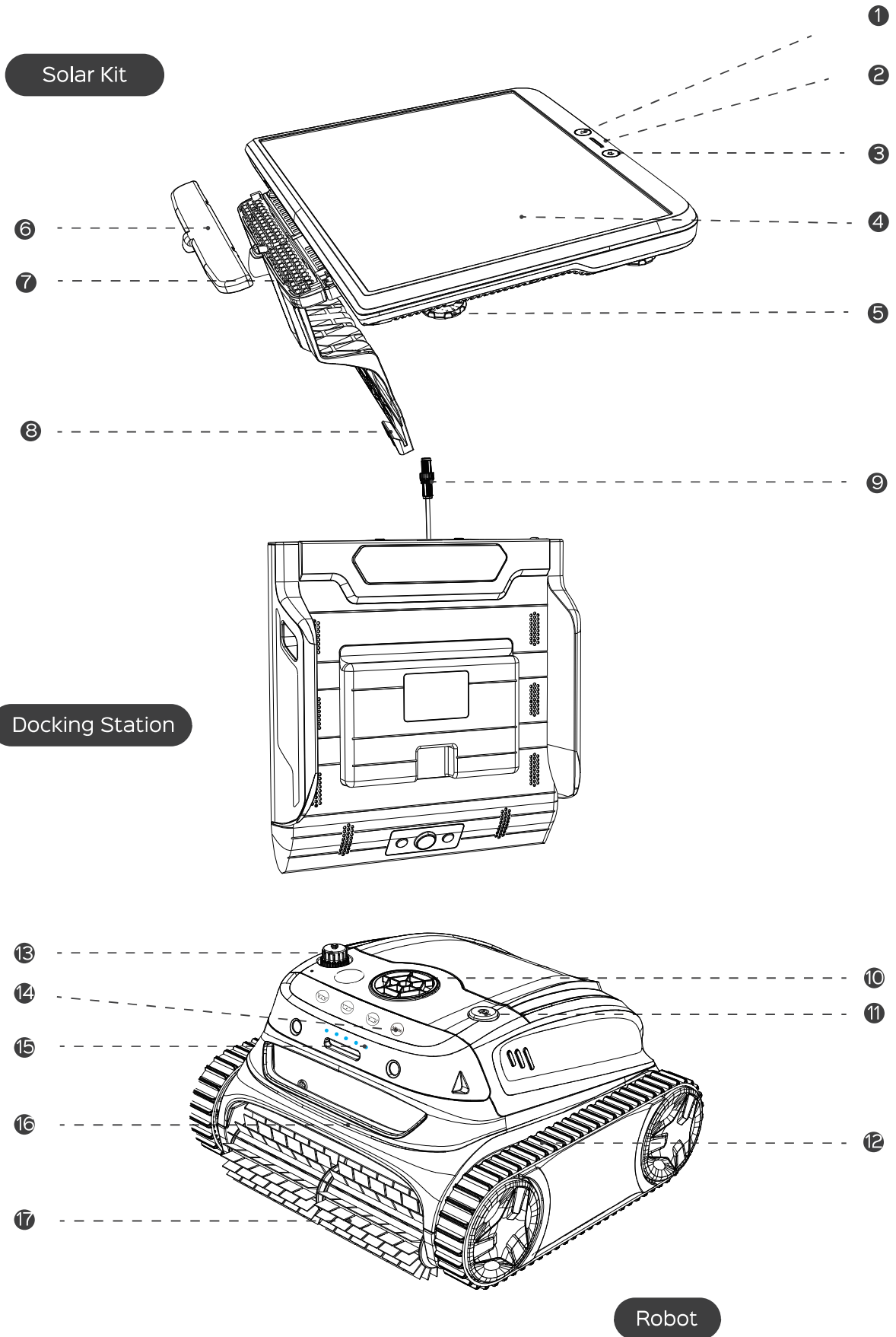

01/WYBOT AT A GLANCE

Product External Overview

- 1 Start Button**
Start the solar panel and routine cleaning.
- 2 LED indicator**
Tell current statuses of the robot.
- 3 Home Button**
Call the robot back to the docking station.
- 4 Solar Panel**
Charge the robot.
- 5 Level Screw**
Adjust the position of the solar kit.
- 6 Protective Cover**
Protect the solar kit.
- 7 Angle Adjustment Screw**
Adjust the angle of solar kit to fix the station well.
- 8 Hook**
Hook up the docking station.
- 9 Power Connector**
Connect the docking station to the solar kit.
- 10 Pump**
pump out water through the window
- 11 on/off Button**
Turn on/ turn off the device
- 12 Track**
Enhance device's capability in climbing walls and various obstacles
- 13 Charging Port**
Connect the charger
- 14 Mode toggle**
Touch to select a mode
- 15 LED indicator**
Tell current statuses of the robot.
- 16 Handle**
Remove and transport the device with it
- 17 Scrubbing Brush**
Knock loose all dirt and roll them all into the device

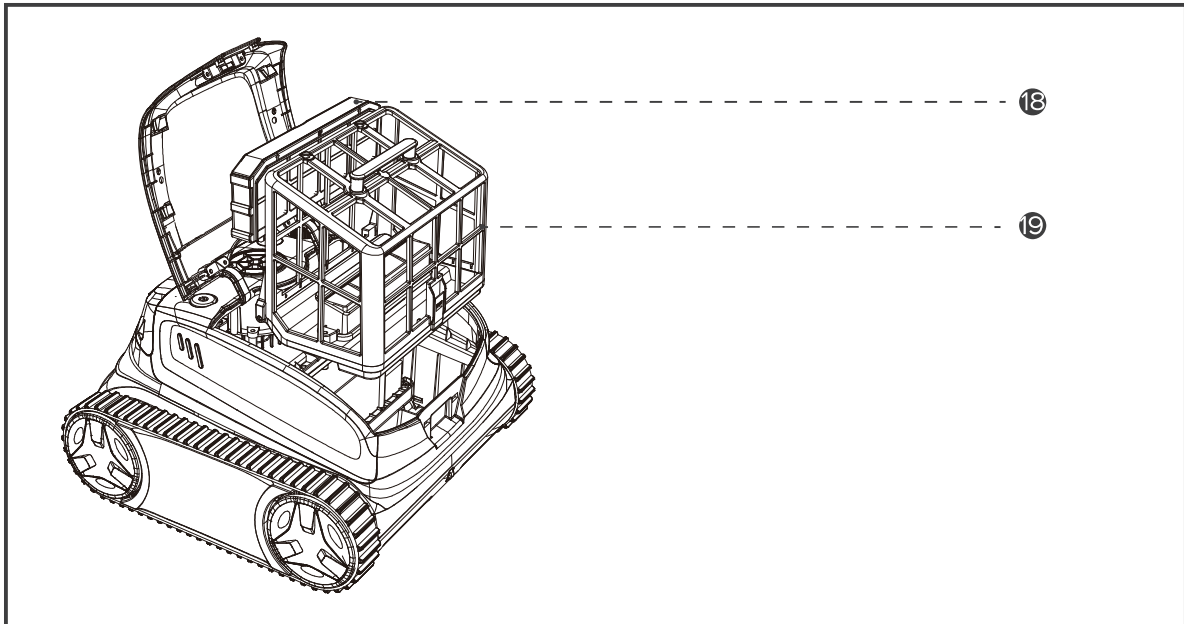
**18 Ultra-fine Filter**

Cotton foam is an auxiliary filter to help trap the fine dirty particles. Recommend to use it for floor cleaning. Please do not install it when the pool water is heavy dusty, it may influence the operation of the cleaner.

19 Filter Basket

Store collected dirt and debris, remember to install it before start cleaning, and wash it after each use.

01/WYBOT AT A GLANCE

Packing List

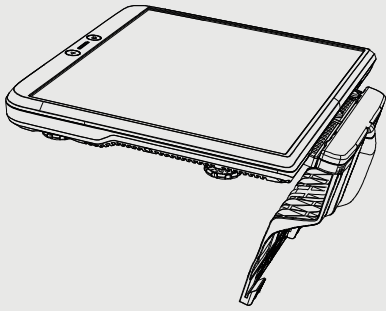

Solar Kit x 1

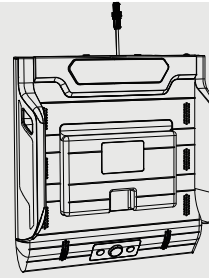

Docking Station x 1

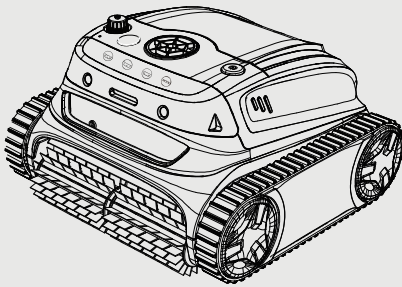

Robot x 1

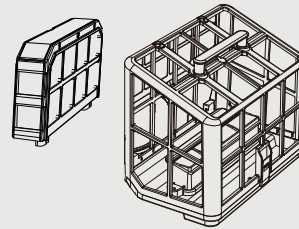

Filters x 2



Use Guide x 2

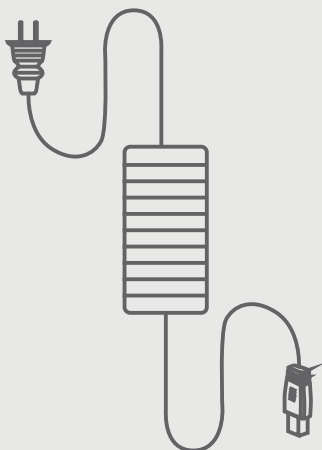

Charger x 1

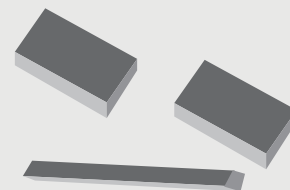

Floating Blocks

02 / INSTALL SOLAR KIT

To keep the robot always energetic, the solar kit supplying power continuously to the robot should be installed well.

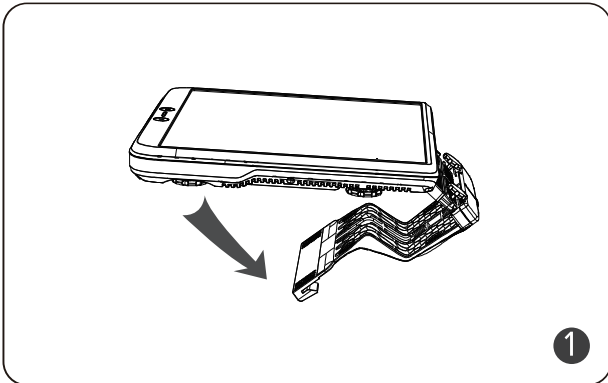

Take out the included solar kit and unfold the hook to the vertical position.

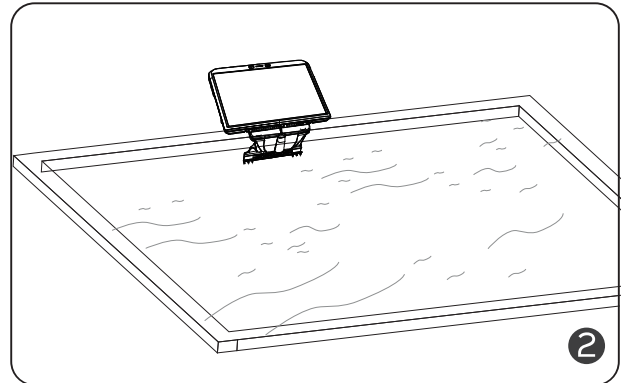

Put the solar kit onto the pool deck where surface is flat and there is no steps or ladders around.

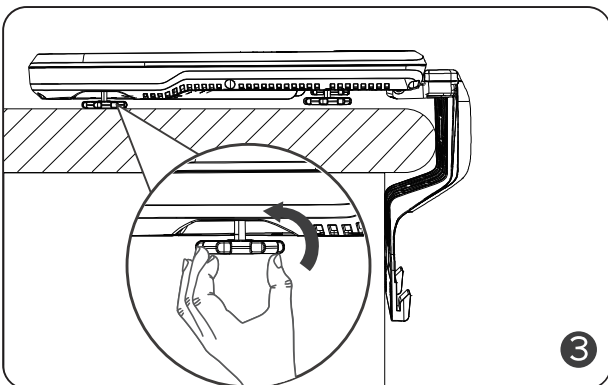

Adjust the height of the level screws on the bottom of the solar kit, ensuring the solar panel on the deck is flat enough.

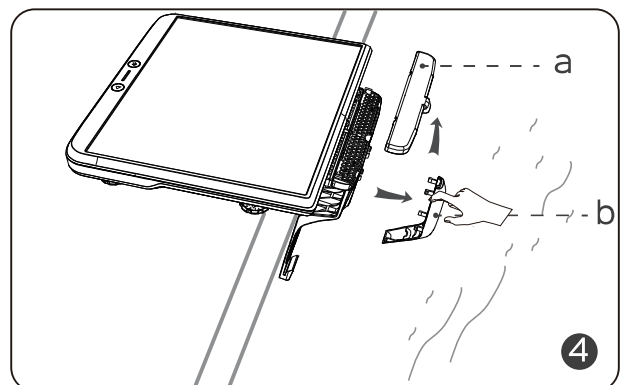

Remove the covers (the order is a then b.) on the solar kit, and put them aside.

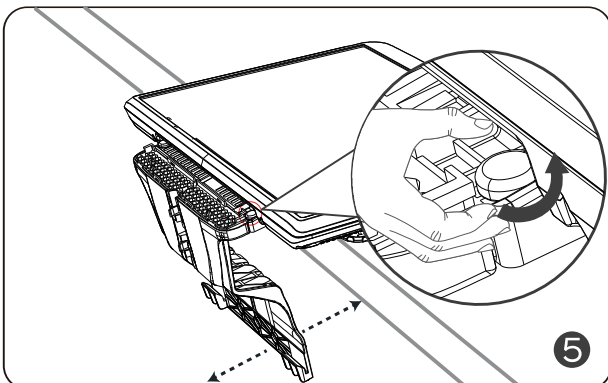

Adjust the height of the screw to ensure the hook press against the wall tightly, and tighten them after fixing.

03 / HOOK UP DOCKING STATION

Note:

You should avoid put any pressure onto the solar panel when installing it.

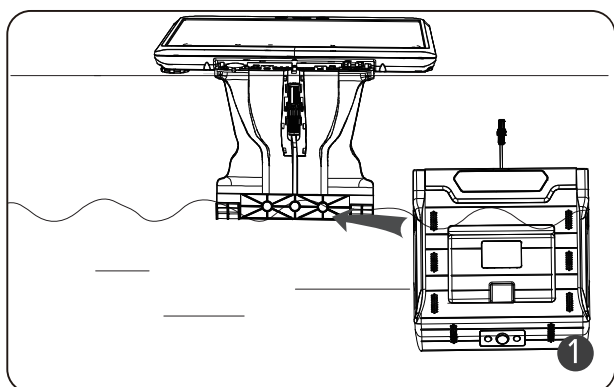

Hook up the docking station to the solar kit, keeping the whole set stable after installation.

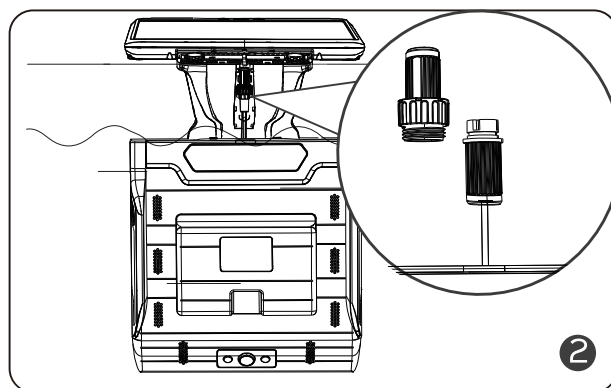

Unscrew the protective caps on the ends of solar kit and docking station, and then connect them to form a complete power cable.

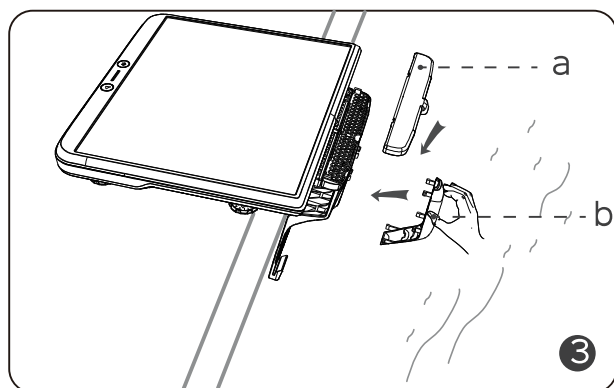

Put the covers (the order is b then a.) back to the solar kit.

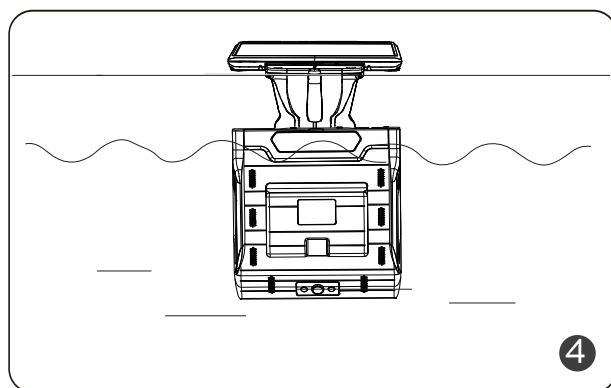

Complete the whole installation.

Note:

1. You should ensure the place where the docking station installed is flat and exists no damage if your pool surface is PVC.
2. Please keep the cable ends of both solar kit and docking station are dry before screwing them together.
3. The water depth of the installation area shall reach 1.2m at least, and there should be no steps, sitting area or light under the docking station.

The device has a lithium-ion rechargeable battery, and you need to charge the battery before first use and when the battery is low.

Charge your robot using DC charger

Connect your device to a power outlet using the included cable and adaptor.

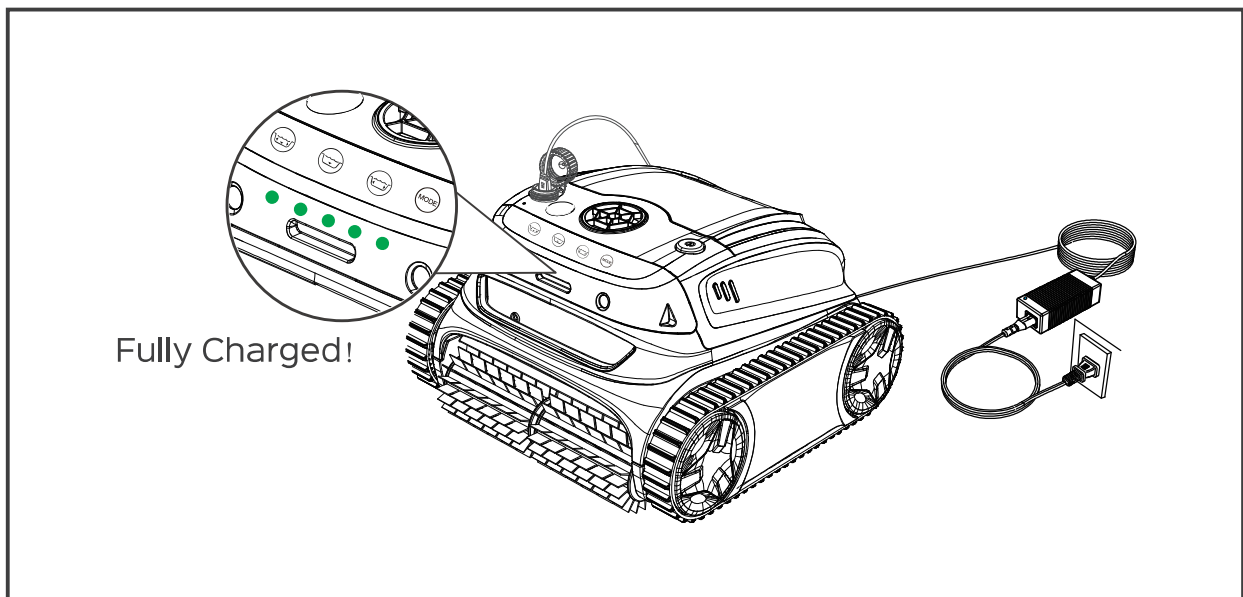

The adaptor has an indicator, which will display blue light  indicating the power supply status.

The LED indicators on the top of the cleaner turn solid green light when fully charged.

Note:

1. When charging, you should ensure your device at least 3m (appr. 10ft) away from the edge of the pool.
2. For reducing fire risk, keep your device and adaptor away from direct sunshine or water when charging.
3. For your important safety, you need to double check the device is powered off and the charging port is dry before charging.
4. The best charging environment is temperature at 32°F -95°F (0°C -35°C), RH at 5%-95%.

Charge your robot using solar panel

After installing your solar kit and docking station, you can start charging your robot.

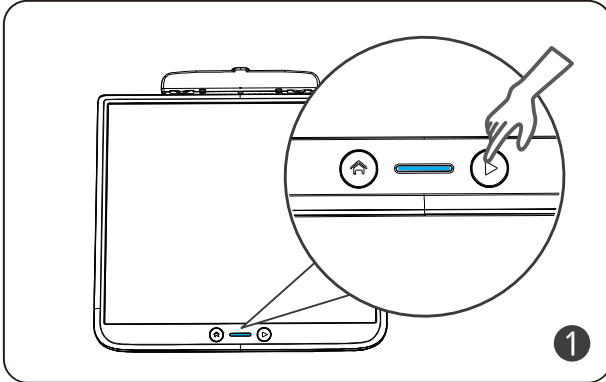

Press the start button on the solar kit to turn on the solar panel and docking station. *(If no light is indicated, please leave the solar kit and docking station under the sun for 2 hours.)*

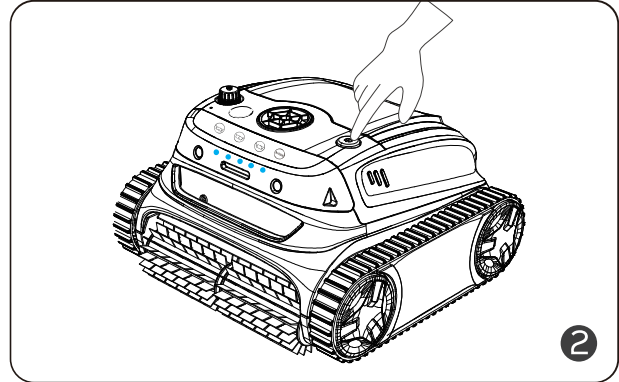

Turn on the device by pressing the on/off button. The LED indicator on the top will display a solid green to display current battery level and then a solid blue when the device is on.

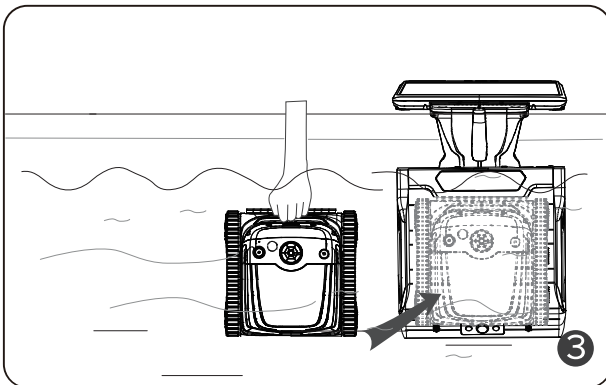

Hold the handle of the cleaner, emerge the robot into the pool. Put it directly onto the docking station to start charging after shaking off inside air.

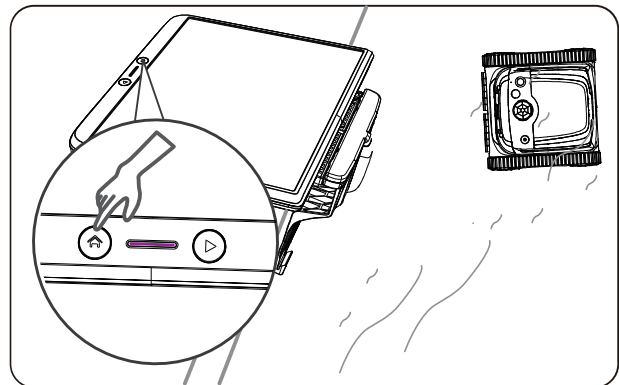

Or, you can put the robot into the pool vertically. Wait until the robot has completed self-calibration. Press the home button to call it back to charge.

Note:

1. Keep your docking station beneath the water when starting charging.
2. No charging devices on shore using docking station.
3. When sending orders to the robot using solar kit, you need waking the device first pressing any button onside, then starting sending orders.
4. If the weather is not favourite, or the robot is at low battery, recommend to put the robot onto the docking station directly.

Below is the indication of the LED lights, you may refer to it to know different device status.

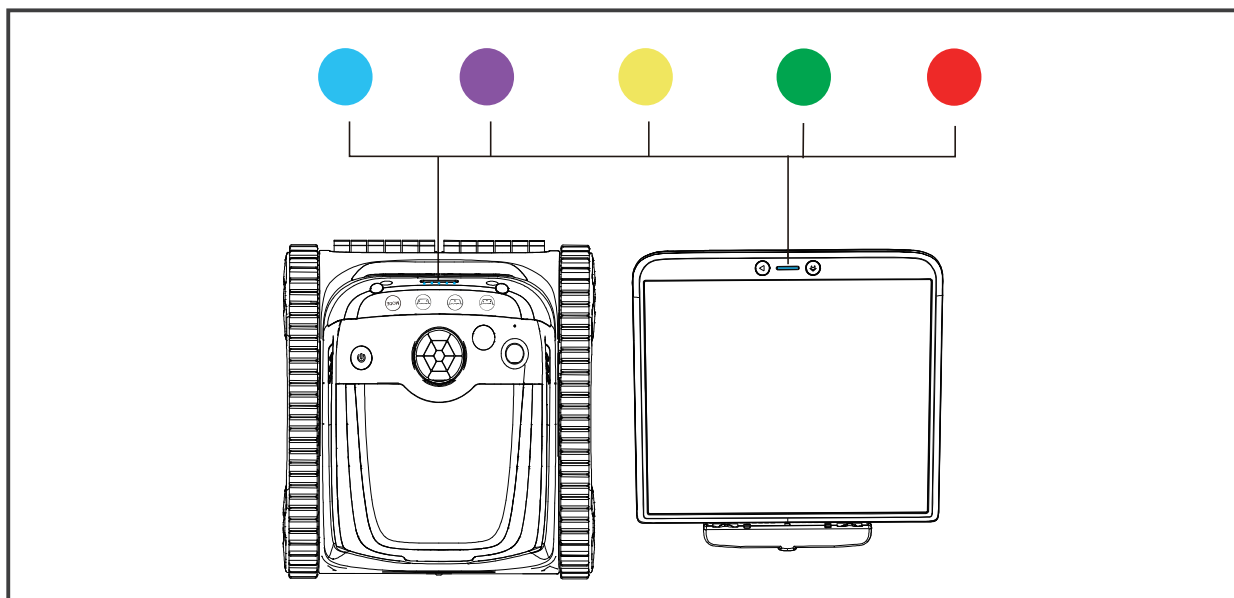

Device	LED Light	Indication	Status
Robot	●	Solid	Power On
		Flashing	Under working
	●	Solid	Connecting to App & Current cleaning mode
	●	Flashing	Low battery or under self-parking in the pool
	●	Flashing	Charging in progress
		Solid	Fully charged
●	Solid or flashing	Fault	
Solar Kit	—	Solid	Power on
	—	Solid	Able to control the robot
	—	Solid or flashing	charging
	—	Solid or flashing	Fault

Note:

1. For maintaining a favourite working status, you need to keep the docking station always being powered on.
2. When yellow light flashes, the robotic pool cleaner will back to the docking station for the inductive charging.
3. If red LED light is on, you can find solution from trouble shooting in this manual or call for service.

Connect to your App

You can download the WYBOT App to your smart mobile device by scanning QR code below, or from Google Play or App Store.



iOS	Android
iOS 15.0 or later	Android 8.0 or later

Note:

Before connection to your App, please ensure your cleaner is charging on the docking station.

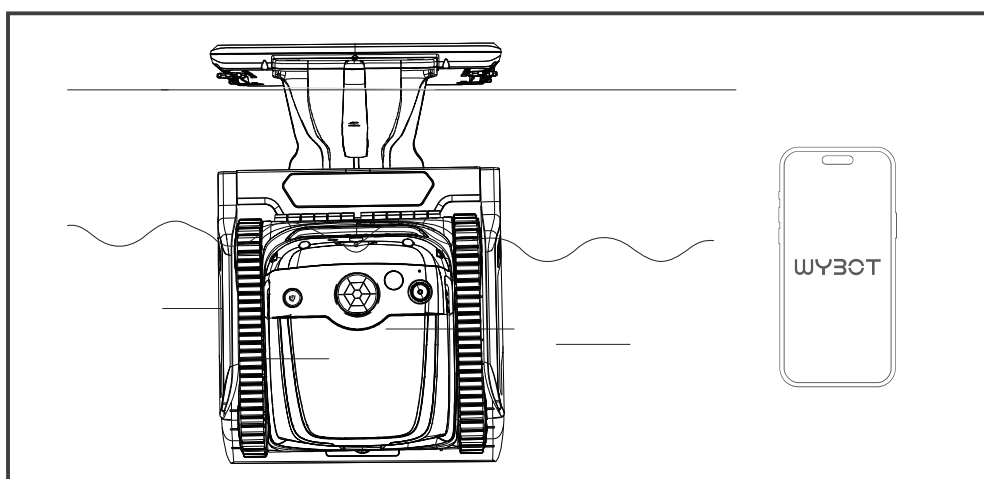





04 / GET STARTED

Setup your new WYBOT

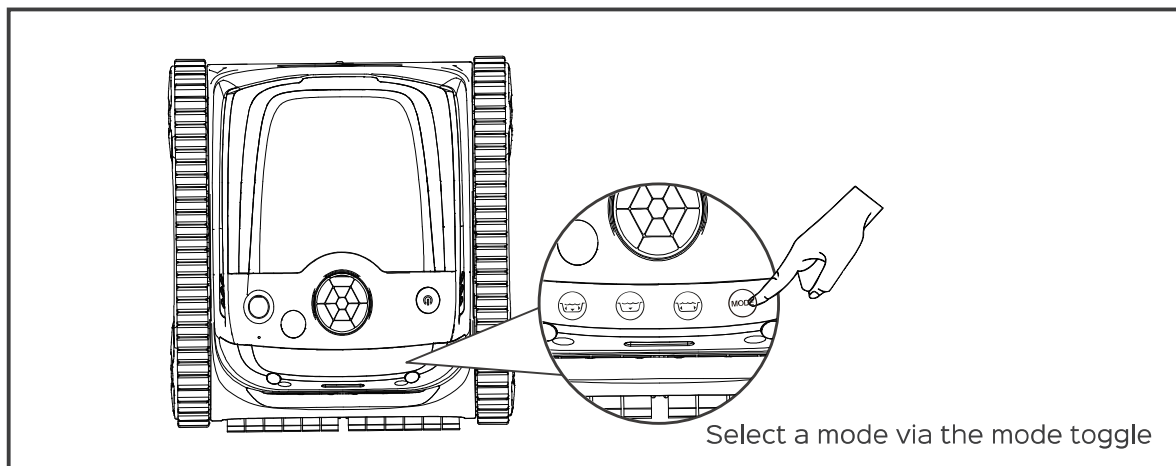
Choose your cleaning mode

You can choose a cleaning mode for your cleaner through the app after connecting to your robot or touch the mode toggle.



Cleaning Mode	Icon (Robot)	Cleaning Coverage
		Toggle a cleaning mode
Standard full pool Wall then floor (Combo)		Wall+ Floor+Waterline
Floor only Turbo floor Eco floor		Pool floors
Wall only		Pool walls

Note:

1. The default mode is 'Wall then floor', and you can customize each icon's specific mode using the app. Eg, set up that the icon '☐' represents Turbo floor mode.
2. If the device restarts, it will automatically enter the cleaning mode you set last time.

04 / GET STARTED

Run your new WYBOT

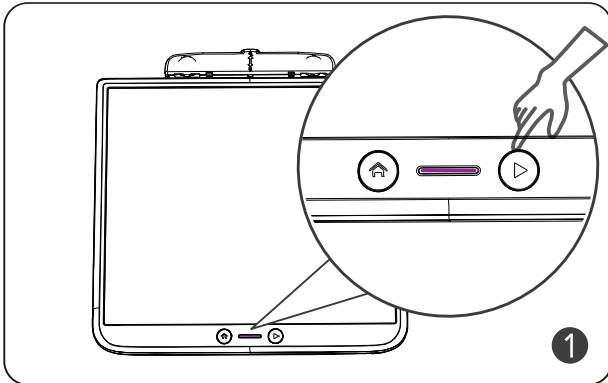

Press the start/stop button on the docking station or click the start cleaning button on the APP to start the pool cleaning.

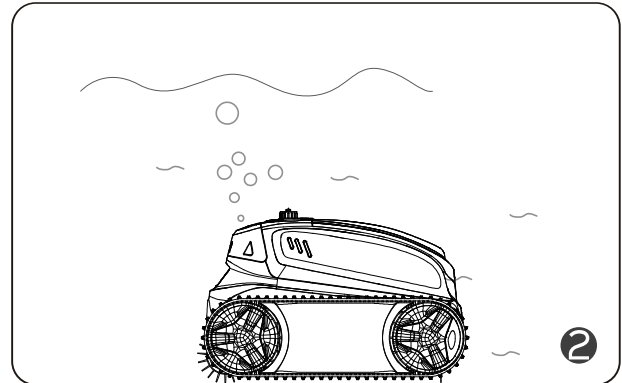

Let it move back to the pool floor.

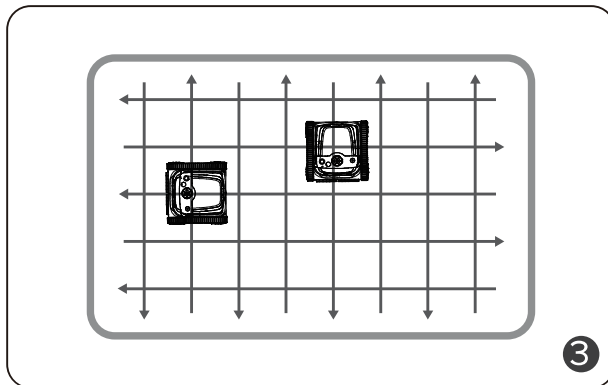

The robot begins to clean walls, floor and waterline as default or your set through App.

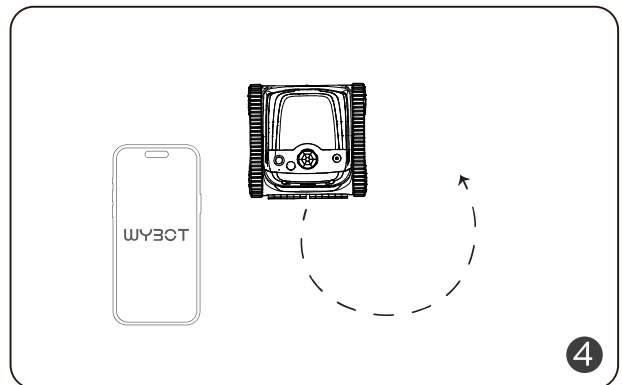

You can control the cleaner remotely and complete the specific area cleaning via the App.

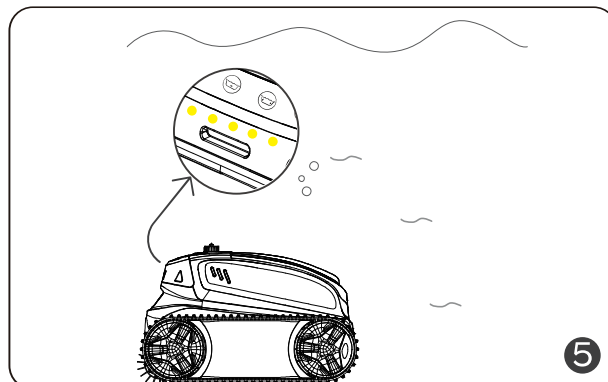

The robot will automatically move to stop by the edge of wall when finishing cleaning or battery is low.

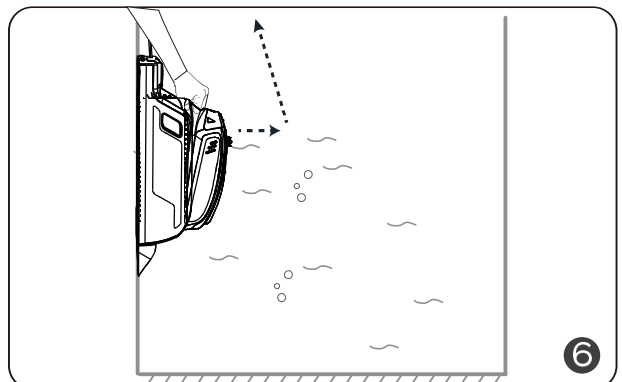

Remove the robot out of the pool, and power it off.

05 / DO A FILTER CLEANING

Press the filter cover handle and lift the cover up.

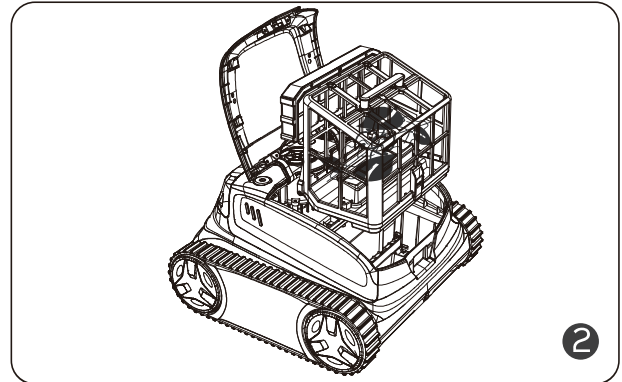
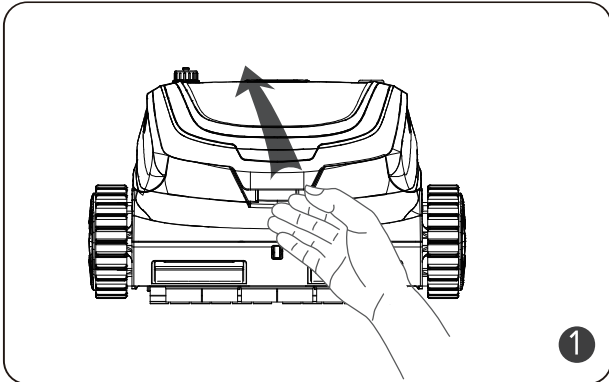

Note:

1. You should ensure the device is power off when open the top cover.
2. You need to clean the filter basket after each use.

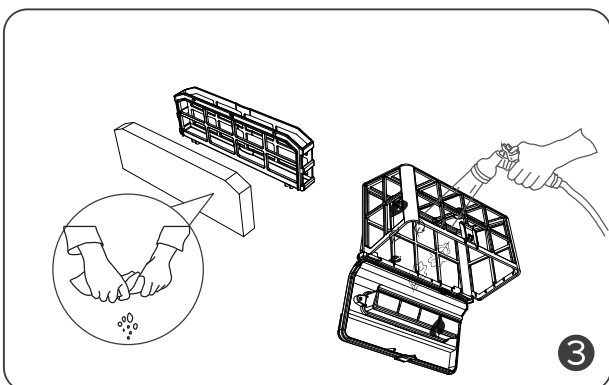

Empty all debris and rinse them with clean water.

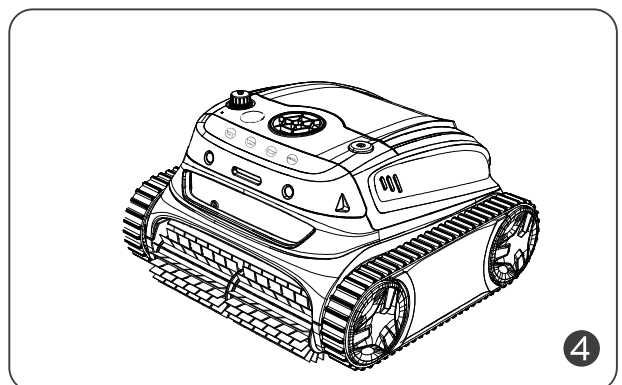

After rinsing, put the filter basket and ultra-fine filter into the cleaner and close the cover.

Note:

1. As electric components inside the cleaner, store the cleaner in a cool and ventilated place, away from direct sunshine or any heat source.
2. Charge the cleaner prior to being stored for a long time (over 6 months) to maintain an optimal battery life.

06 / PUT BACK TO DOCKING STATION

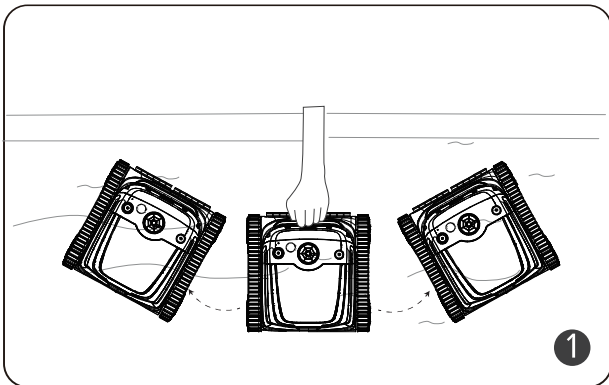

Hold the handle of the cleaner, and shake off inside air. Put it into the pool vertically. Wait until the robot has completed self-calibration.

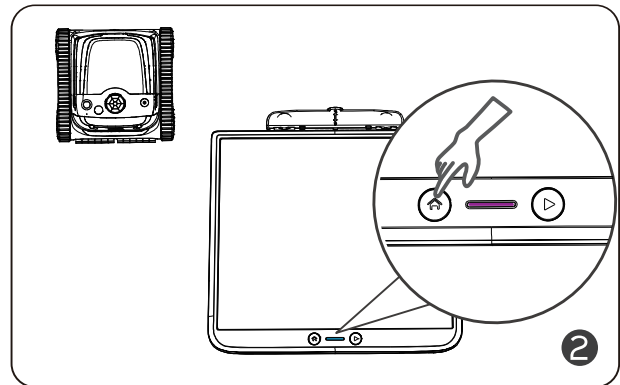

Press the home button on the solar kit to call the robot back to the docking station.

If your robot is powered off because of the low battery, you can put it onto the docking station manually.

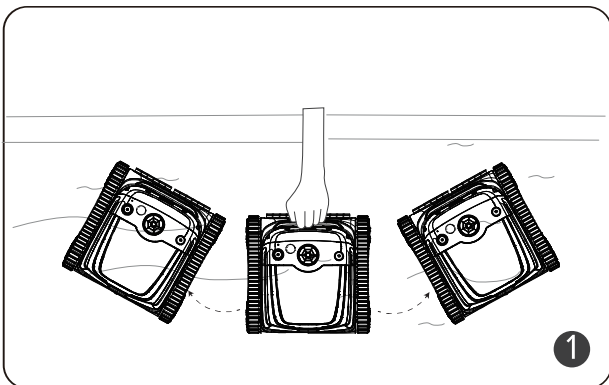

Shake the cleaner horizontally to empty trapped air inside.

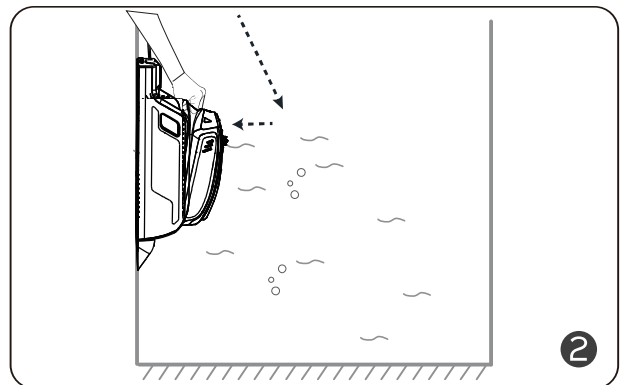

Put the robot onto the docking station carefully.

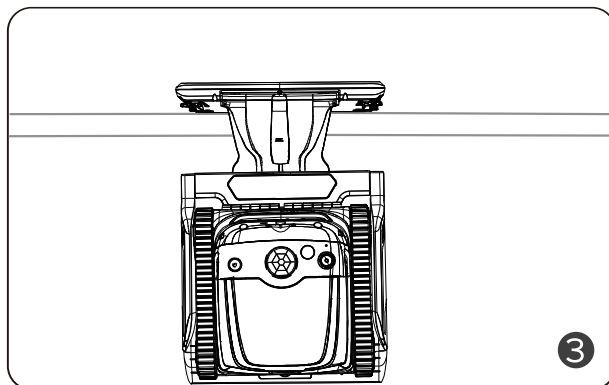

Start to fully charge itself automatically and keep standing by for next cleaning cycle.

07 / DEVICE SPECIFICATION

Model	WYBOT S2 Solar
Pool Size	Up to 300m ² (3229.173ft ²)
Depth	9.8ft (3m)
Device Dimension	400(L)*390(W)*255(H) mm
Weight	8.5 Kg (Robot)+12.5Kg (Solar+Station)
Runtime	2.5 hours
Charging Time	3 hours (DC charging)
Voltage	Battery/25.9V
Power	90W
Charger Input	100-240V, 47-63Hz
Charger Output	29.4V/2.2A
Battery Capacity	5200mAh
Filtration	Double-level
Flow Rate	14m ³ /H (3962GPH)
Moving Speed	10m/min.
Water Resistance	IPX8
OTA upgrading	Available
App Connection	Available

08 / LIMITED WARRANTY

1. All WYBOT pool cleaners in the market have been inspected and licensed to be sold as per local laws.
2. The warranty applies only to original buyers, and not valid to resale and any other kinds of transfer.
3. Any damages to the unit caused by improper use, unauthorized repair or disassembly are not covered by WYBOTICS Co., Ltd.'s warranty.
4. The order number or record must be presented for any claim or repair within the warranty period.



Scan the QR code for the warranty policy.

09 / HOW TO MAINTAIN YOUR DEVICE

You should follow the steps to store your cleaner to maintain good performance.

- a) Ensure the device is power off
- b) Dry out the cleaner
- c) Fully charge the battery
- d) Store the cleaner in a cool and ventilated place, away from direct sunshine, heat source, frost and squeezing with an ambient temperature between 5°C / 41°F and 45°C / 113°F.
- e) Charge the cleaner every three months to ensure an optimal battery life.
- f) Keep the solar kit away from any pressure

Note:

If your device do not work after a long-term low battery life or being off, please contact after-sale team for help. For your safety, do not try to disassemble it without authorization.

10 / FAQ & TROUBLE SHOOTING

Q: What pool shapes and construction materials is the cleaner suitable for?

A: The machine can be applied to rectangle, oval, or irregular shapes of in-ground swimming pools. Applicable construction materials include PVC, guinite, tile and other materials.

Q: Will obstacles such as steps, shallow water areas, drains, slopes etc. in the swimming pool affect the running?

A: The machine can climb steps, drains, and shallow water areas. The above obstacles may influence its cleaning path, but will not affect the operation of the machine.

Q: Are the WYBOT App able to control the device when cleaning under water?

A: Yes, but you should connect your robot to the app when the robot is docking onto it. You can schedule your cleaning and control it remotely at anytime.

If you encounter the following situations when using the cleaner, you can check the table and solve them by yourself.

If you can not find a solution from the table, please contact after-sale team.

10 / FAQ & TROUBLE SHOOTING

No.	Issues	Details	Possible Causes	Suggested Solution
1	Cannot charge	All LED indicators show green	Sealed parts or charger are damaged.	Contact for change.
		No LED indicators show	The device does not have a good contact with the docking.	Adjust the position.
2	Charger light dies	Plug into the power supply well, but no light shows.	The charger is damaged.	Contact for change.
3	Cannot be turned on	No LED indicators show	Low battery.	Charge the device.
4	Does not work	LED indicators die after a while.	Automatically power off 3 min after no operation.	Relaunch the device.
		Show solid red light	Impeller or filtration basket is stuck.	Open to clean.
		Show flashing red light	Overheat protection.	Relaunch the device after a while.
		Show flashing yellow light	Low battery.	Charge the device.
5	Cannot clean the wall		Wrong cleaning mode.	Choose wall cleaning mode.
			Heavy dirty pool water.	Clean filtration system.
			Use cotton foam.	Remove cotton foam.
			Gyro need be calibrated.	Calibrate it using the App.
			Device weight it heavy.	Install floating parts.
6	Low cleaning coverage		Firmware is not the latest version.	Update it using the App.
			Floor cleaning mode	Switch to full-pool cleaning.
7	The front part raises frequently		Full filtration basket	Clean filtration system.
8	Cleaning path is not patterned		Gyro need be calibrated.	Calibrate it using the App.
9	The device is stuck at main drains or floor lights		The obstacle is hight than 30mm (1.2ft)	Manually unstuck the device.
10	Cannot call the device back to the docking station.		No power supply for the docking station	Connect to the power supply.
			The docking station need be calibrated.	Contact for calibration.

11 / CERTIFICATION

WYBOT robotic pool cleaners have passed all performance and reliability tests and also has obtained relevant certifications from the countries in which they are sold. you can rest assured.



12 / WYBOT CUSTOMER CARE

Due to the need for continuous products improvement, the products in the manual are subject to the real products, and WYBOTICS Co., Ltd. reserves the right to update products.

If you encounter any problems during use, please contact after-sale team.

For more details, please contact WYBOTICS website www.wybotpool.com

Wybot Customer Service:

Email: support@wybotpool.com

Facebook: @WybotPool

Tel: 1-866-777-6655



Scan the QR code for the e-Manual.