

INSTALLATION MANUAL





PLEASE READ THE MANUAL CAREFULLY BEFORE INSTALLATION & OPERATION AND RETAIN IT FOR FUTURE REFERENCE.



Adherence to the directions for use in this manual is extremely important for health and safety. Failure to strictly adhere to the requirements in this manual may result in personal injury, property damage and affect your ability to make a claim under the manufacturer's warranty provided with your product. Products must be used, installed and operated in accordance with this manual. You may not be able to claim on the manufacturer's warranty in the event that your product fault is due to failure to adhere this manual.

1. IMPORTANT SAFETY INSTRUCTIONS



This guide provides installation and operation instructions for this pump. If you have any other questions about this equipment, please consult your supplier.

1.1 When installing and using this electrical equipment, basic safety precautions should always be followed, including the following:

- **RISK OF ELECTRICAL SHOCK.**
Pool pump must be installed on a RCD protected circuit. Check your local state regulations and wiring rules.
- This water pump must be earthed in accordance to local and national regulations. Earthing point is clearly labelled on pump
- This pump is for use with permanently installed in-ground or above-ground swimming pools and may also be used with hot tubs and spas with a water temperature under 50°C. Due to the fixed installation method, this pump is not suggested to be used on above-ground pools that can be readily disassembled for storage.
- The pump is not submersible.
- Never open the inside of the drive motor enclosure.

1.2 All installations must be fitted with earth leakage or residual current protection devices, having a rated residual operating current not exceeding 30mA.

- Fill the pump with water before starting. Do not run the pump dry. In case of dry run, mechanical seal will be damaged and the pump will start leaking.
- Before servicing the pump, switch OFF power to the pump by disconnecting the main circuit to the pump and release all pressure from pump and piping system.
- Never tighten or loosen screws while the pump is operating.
- Ensure that the inlet and outlet of the pump are unblocked with foreign matter.
- This pump must be equipontental bonded to local and national regulations.

CONTENTS

1. IMPORTANT SAFETY INSTRUCTIONS	2	6. EXTERNAL CONTROL	7
2. TECHNICAL SPECIFICATIONS	3	a. Digital input	7
3. OVERALL DIMENSION	3	7. PROTECTION AND FAILURE	8
4. INSTALLATION	3	7.1 High Temperature Warning and, Speed Reduction	8
4.1 Tools required	3	7.2 Undervoltage protection.	8
4.2 Pump Location	4	7.3 Troubleshooting	8
4.3 Piping	4	7.4 Error code	8
4.4 Valve and Fittings	4	8. MAINTENANCE	9
4.5 Check before initial startup.	4	9. DISPOSAL	9
4.6 Application conditions	4	10. DIAGRAM	10
5. SETTING AND OPERATION	5	11. WARRANTY & EXCLUSIONS	11
5.1 Display on control panel	5		
5.2 Startup	5		
5.3 Self-priming.	5		
5.4 Running Capacity Setting.	6		
5.5 Timer mode.	6		
5.6 Parameter settings	6		

2. TECHNICAL SPECIFICATIONS

Model	Advised Pool Volume	INPUT POWER		Voltage (V/Hz)	Max Flow (L/min)	Head Max (m)	Circulation	
		Power KW	Power HP				Flow at 8m L/min	Flow at 10m L/min
INVFLO300	30~70	0.75	1.00	220~240 50/60	350	16.0	300	233
INVFLO400	50~100	1.00	1.50	220~240 50/60	425	18.0	367	300

3. OVERALL DIMENSION (mm)

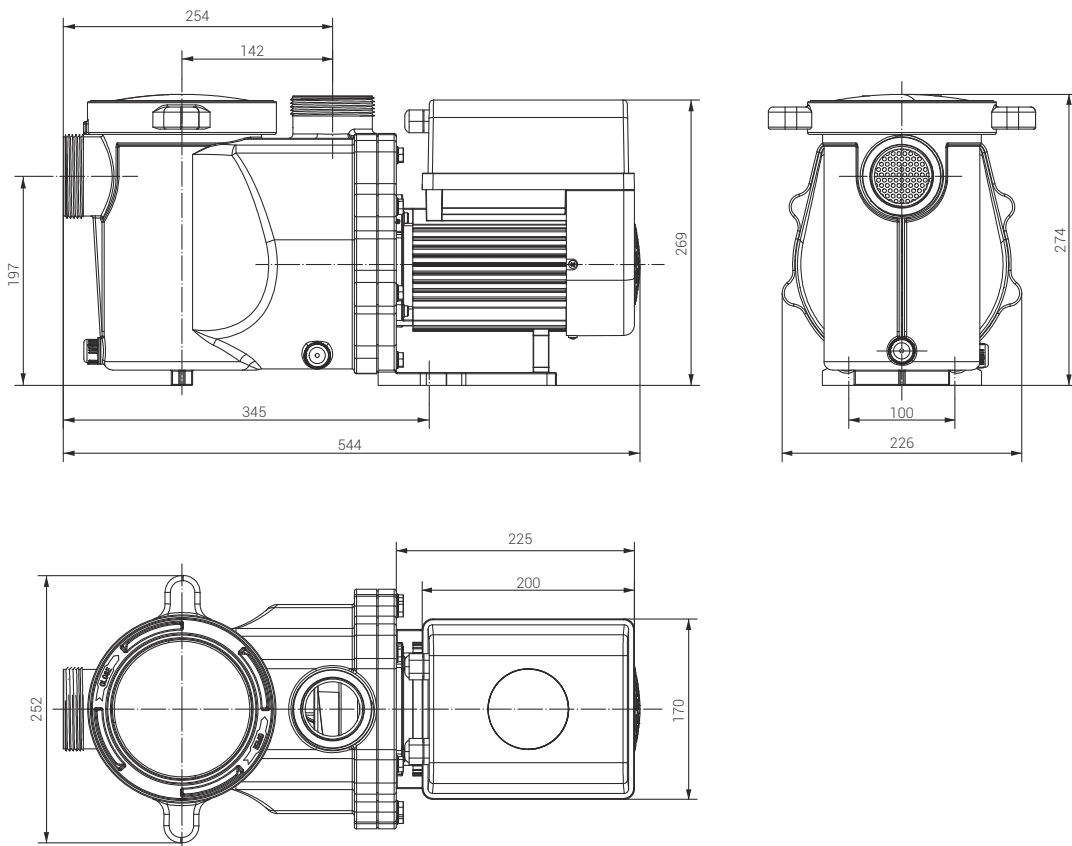

4. INSTALLATION

4.1. Tools required

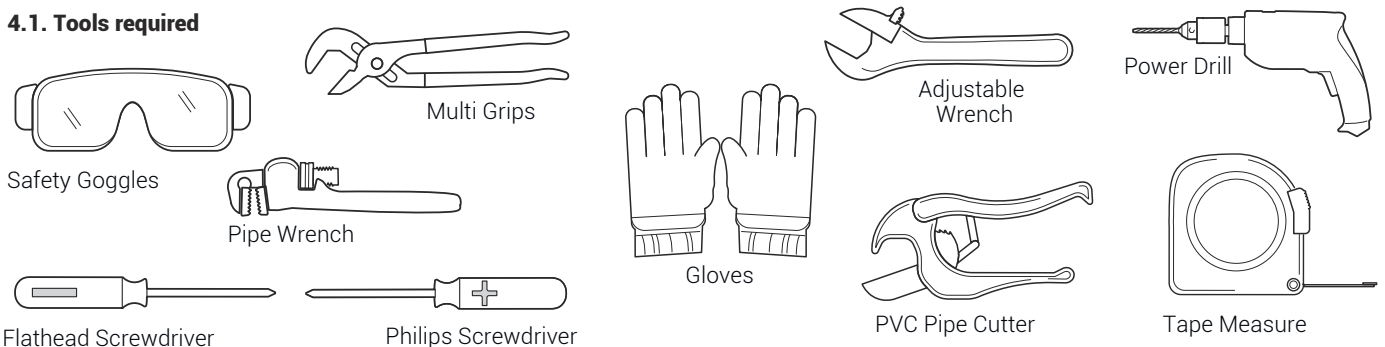

continue INSTALLATION

4.2 Pump Location

The pump should be installed in an area with at least 150mm distance around the unit away from any obstacles and away from any corrosive products.

- 1) Install the pump as close to the pool as possible, to reduce friction loss and improve efficiency, use short, direct suction and return piping.
- 2) To avoid direct sunshine, heat or rain, it is recommended to place the pump indoors or in the shade.
- 3) DO NOT install the pump in a damp or non-ventilated location. Keep pump and motor at least 150mm away from obstacles, pump motors require free circulation of air for cooling.
- 4) The pump should be installed horizontally and fixed in the hole on the support with screws to prevent unnecessary noise and vibration.

4.4 Valves and Fittings

It is recommended to install isolation valves on the suction and return lines for easier maintenance of the pool pump.

Elbows should be no closer than 350mm to the inlet.

Do not install 90° elbows directly into the pump inlet/outlet.

Joints must be tight.

4.3 Piping

Suction and return connections on the pool pumps are 50mm pressure pipe dimensions.

- 1) For optimization of the pool plumbing, it is recommended to use a pipe with size of 50mm. When installing the inlet and outlet fittings (joints), use the special sealant for PVC material.
- 2) The dimension of suction line should be the same or larger than the inlet line diameter, to avoid pump sucking air, which will affect the efficiency of the pump.
- 3) Plumbing on the suction side of the pump should be as short as possible.
- 4) For most installations we recommend installing a valve on both the pump suction and return lines, which is more convenient for routine maintenance. However, we also recommend that are valve, elbow, or tee installed on the suction line should be no close to the front of the pump than seven times the suction line diameter
- 5) Pump outlet piping system should be equipped with a check valve to prevent the pump from the impact of medium recirculation and pump-stopping water hammer.

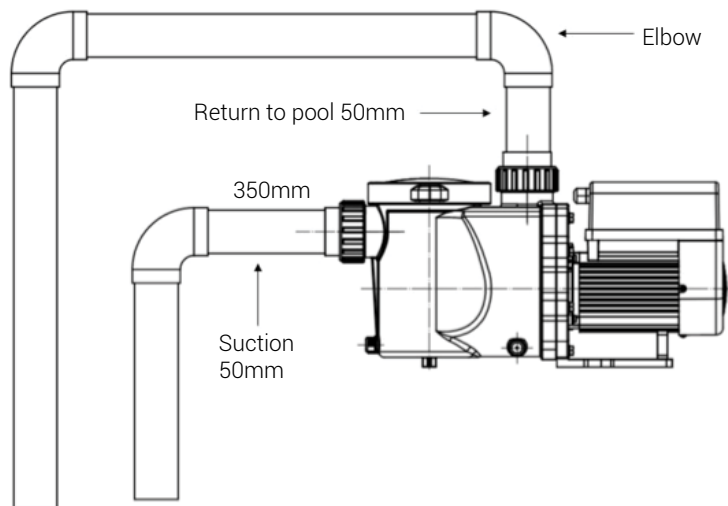

* The pump inlet/ outlet union size: optional with metric 50 or 40mm.

- 2) Below water level system should have an isolation valves installed on suction and return line for maintenance; however, the suction gate valve should be no closer than seven times the suction pipe diameter as described in this section.
- 3) A check valve should be installed if there are long pipe runs above water level or if is significant height between the return line and the outlet of the pump.
- 4) Be sure to install check valves when plumbing in parallel with other pumps. This helps prevent reverse rotation of the impeller and motor.

4.5 Check before initial startup

- 1) Check whether pump shaft rotates freely;
- 2) Check whether power supply voltage and frequency conform to the nameplate;
- 3) Facing the fan blade, the direction of motor rotation should be clockwise;
- 4) It is forbidden to run the pump without water.

4.6 Application conditions

Ambient temperature	Indoor installation, temperature range: -10 ~ 40°C
Water temperature	5°C ~ 50°C
Salt pools	Salt concentration up to 0.5%, i.e. 5g/L
Humidity	≤ 90% RH, (20°C±2°C)
Altitude	Not exceed 1000m above sea level
Installation	The pump can be installed max. 2m above water level
Insulation	Class F, IP55

5. SETTING AND OPERATION

5.1 Display on control panel:

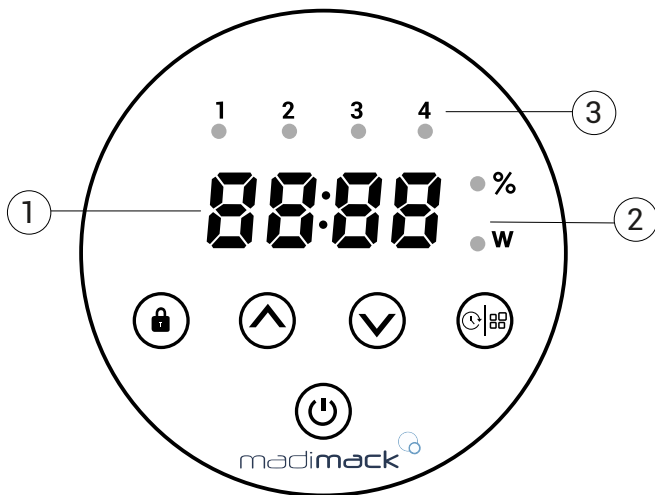

1	Running capacity / power display
2	Running capacity / power indicator
3	Timer indicator 1/2/3/4

	Unlock
	UP
	DOWN
	Timer setting / power reading
	On/ Off

To change the value of the setting.

5.2 Startup

When the power is switched on, the screen will fully light up for 3 seconds, the device code will be displayed, and then it will enter the normal working state. When the screen is locked, only the button will light up; Press and hold for more than 3 seconds to unlock the screen. The screen will automatically lock up when there is no operation for more than 1 minute and the brightness of the screen will be reduced to 1/3 of the normal display. Short press to wake up the screen and observe the relevant operating parameters.

5.3 Self- priming

When switched on for the first time after installation, the pump will start self-priming.

When the pump performs self-priming, it will count down from 1500s and stop automatically when the system detects the pump is full of water, then the system will recheck for 120s again to make sure the self-priming is completed.

User can exit self-priming manually by pressing for more than 3 seconds. The pump will enter the default Manual-Inverter mode at the initial startup. If the user exits the self-priming in the subsequent startup, the pump will return to the previous state before the last shutdown.

Remark:

The pump is delivered with self-priming enabled. Each time the pump restarts, it will perform self-priming automatically. Users can enter the parameter setting to disable the default self-priming function (see 5.7)

If the default self-priming function is disabled, and the pump has not been used for a long time, the water level in the strainer basket may drop. Users can manually activate the self-priming function by pressing both for 3 seconds, the adjustable period is from 600s to 1500s (default value is 600s). After the manual self-priming is completed, the pump will return to the previous state before activating the manual self-priming.

User can press for more than 3 seconds to exit the manual self-priming.

continue SETTING AND OPERATION

5.4 Running Capacity Setting

1		Hold for more than 3 seconds to unlock the screen.
2		Press to start. The pump will run at 80% of the running capacity at the initial startup after the self-priming.
3	or	Press or to set the running capacity between 30%~100%, each step by 5%. For the purpose of backwashing, users can set a high running capacity according to the size of filter.
4		Hold for more than 3 seconds to read the real-time power.

Note:

- When the running capacity is adjusted, the system will save the latest parameter automatically.
- When setting 100% speed, the pump will increase the speed automatically if the pipeline resistance is high, but will not exceed the rated power of each model.

5.5 Timer mode

The pump's on/off and running capacity could be commanded by timer, which could be programmed daily as needed. Maximum 4 timers can be set on the control panel.

1	Enter timer setting by pressing .
2	Press or to set the local time. Press to confirm and move to timer-1
3	When enter the timer-1 setting, the timer indicator 1 will light up. "StA" will be shown on the screen. Press to proceed and then press or to set the start time of timer-1 (with 30 minutes for each step), press to confirm.
4	When the start time of timer 1 is confirmed, "End" will be shown on the screen. Press to proceed and then press or to set the end time of timer-1 (with 30 minutes for each step), press to confirm.
5	When the end time of timer 1 is confirmed, "SPd" will be shown on the screen. Press to proceed and then press or to set the running capacity of timer-1 (30% - 100%, each step by 5%), press to confirm.
6	When the timer 1 setting is completed, repeat steps 3 – 5 to complete the setting of timer 2 – 4.

NOTE:

When timer mode is activated, if the set time period contains the current time, the pump will start running according to the set running capacity and the corresponding timer indicator (1 or 2 or 3 or 4) will stay on, and the set running capacity will be shown on the screen. If the set time period does not contain the current time, the timer indicator (1 or 2 or 3 or 4) that is about to start running will light up and flash, and the current time will be shown on the screen.

All 4 time periods should be set in chronological order. Overlap setting of time will be considered invalid, the pump will only run based on the previous valid setting.

During the timer setting, if users want to return to the previous setting item, hold both for 3 seconds. If users don't need 4 timers, they can hold for 3 seconds after completing the setting of the specific timer, the system will automatically save the current set value and activate the timer mode.

When the timer mode is on, users can check the setting of each timer. Press to select the specific timer (1 or 2 or 3 or 4), and the corresponding timer indicator will light up. Then press to check the start time, end time, and running capacity setting of the selected timer.

Users can hold for 3 seconds to read the real-time power and exit timer mode by holding for 3 seconds.

5.6 Parameter Setting

Restore factory setting.	Under off mode, hold both for 3 seconds.
Check the software version.	Under off mode, hold both for 3 seconds.
Manual priming.	Under ON mode, hold both for 3 seconds.
Enter parameter setting as shown.	Under OFF mode, hold both for 3 seconds to enter the parameter setting. The parameter address (on the left) and default setting value (on the right) will flash alternately on the screen. Users can press or to adjust the current value, and hold both for 3 seconds to the next parameter address. It will exit the parameter setting after 10 seconds without operation.

Parameter Address	Description	Default Setting	Setting Range
1	Digital input 2	100%	30~100%, by 5% increments
2	Digital input 3	80%	30~100%, by 5% increments
3	Digital input 4	40%	30~100%, by 5% increments
4	Self-priming/Backwash capacity	100%	80~100%, by 5% increments
5	Enable or disable the priming that occurs at start.	25	25:enables 0:disable
6	Self-priming recheck time	2min	1-15min by 1min increments

6. EXTERNAL CONTROL

External control can be enabled via following contacts.

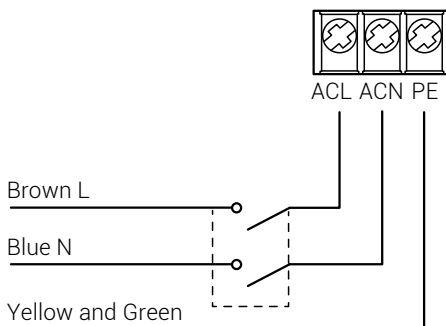
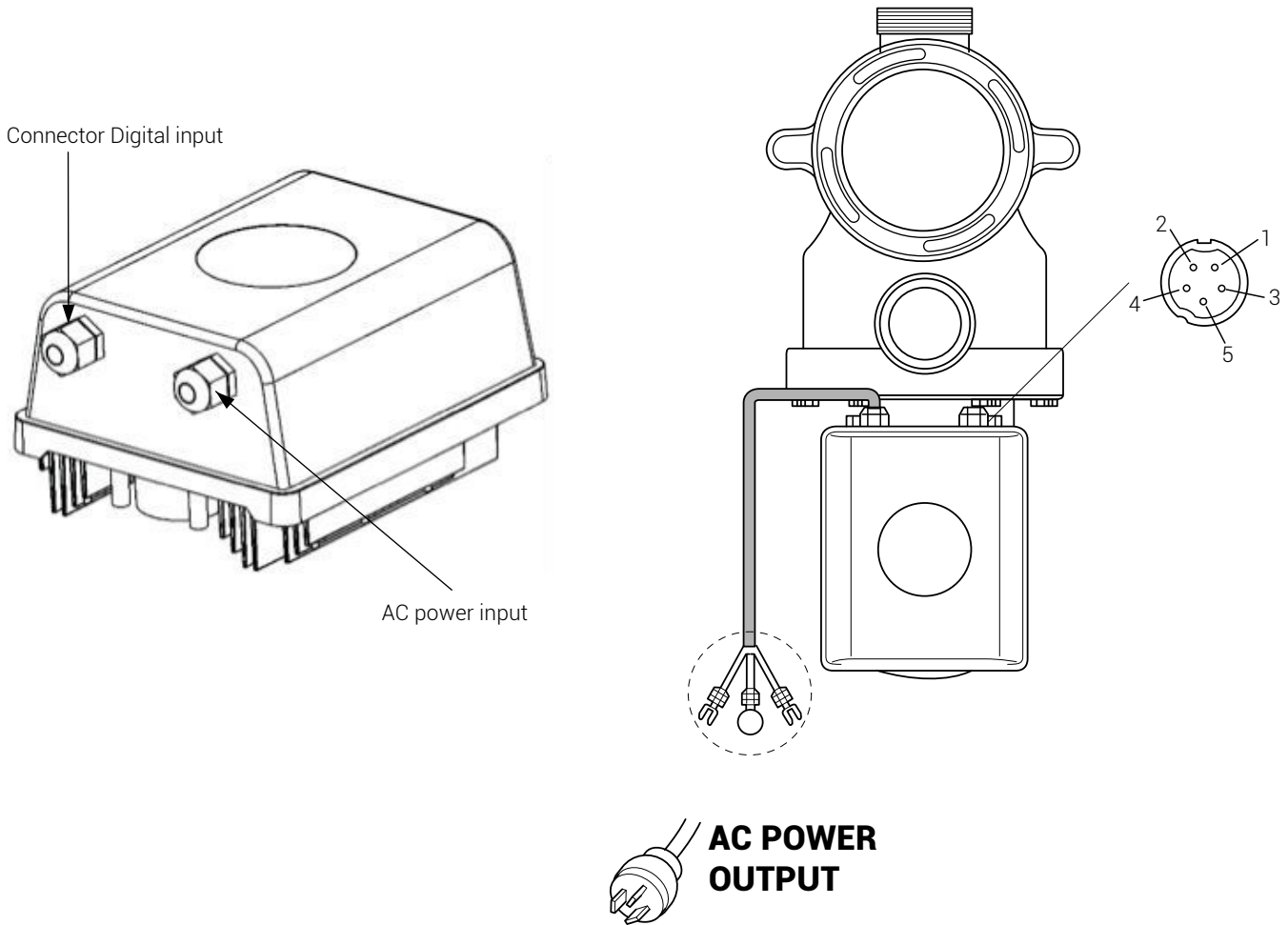

Name	Color	Description	Setting Range	Default Setting
PIN 1	Red	Digital Input 4	30~100%, by 5% increments	40%
PIN 2	Black	Digital Input 3	30~100%, by 5% increments	80%
PIN 3	White	Digital Input 2	30~100%, by 5% increments	100%
PIN 4	Grey	Digital Input 1		Pump Stop
PIN 5	Yellow	Digital Ground		Ground

a. Digital input

Running capacity is determined by the state of digital input, (5 pin)

When PIN4 connect with PIN5, the pump will be mandatory to stop; if disconnected, the digital controller will be invalid;

When PIN3 connect with PIN5, the pump will be mandatory to run at 100%; if disconnected, the control priority will be back on panel control;

When PIN2 connect with PIN5, the pump will be mandatory to run at 80%; if disconnected, the control priority will be back on panel control;

When PIN1 connect with PIN5, the pump will be mandatory to run at 40%; if disconnected, the control priority will be back on panel control;

The capacity of inputs (PIN1/PIN2/PIN3) could be modified according to the parameter setting..

7. PROTECTION AND FAILURE

7.1 High Temperature Warning and Speed Reduction

During normal operation (except backwash/self-priming), when the pump control system reaches the high temperature warning trigger threshold (81°C), it enters the high temperature warning state; when the temperature drops from the high temperature warning release threshold (78°C), the high temperature warning state is released. The display area alternately displays AL01 and running speed or flow.

1) If AL01 displayed for the first time, the running capacity will be automatically reduced as below:

- a. If current operating capacity is higher than 85%, the running capacity will be automatically reduced by 15%;
- b. If current operating capacity is higher than 70%, the running capacity will be automatically reduced by 10%;
- c. If current operating capacity is lower than 70%, the running capacity will be automatically reduced by 5%.

2) Suggestion for non-first displayed of AL01: check the module temperature every 2 minutes. Compared with the temperature in the previous period, for every 1-degree Celsius increase, the speed will decrease by 5%.

7.2 Undervoltage protection

When the device detects that the input voltage is less than 197V, the device will limit the current running speed.

When input voltage is less than or equal to 180V, the running capacity will be limited to 70%;

When the input voltage range is within 180V ~ 190V, the running capacity will be limited to 75%;

When the input voltage range is within 190V ~ 197V, the running capacity will be limited to 85%.

7.3 Troubleshooting

Problem	Possible causes and solution
Pump does not start.	<ul style="list-style-type: none"> • Power Supply fault, disconnected or defective wiring. • Fuses blown or thermal overload open. • Check the rotation of the motor shaft for free movement and lack of obstruction. • Because of long time lying idle. Unplug the power supply and manually rotate motor rear shaft a few times with a screwdriver.
Pump does not prime.	<ul style="list-style-type: none"> • Make sure the pump basket is filled with water and the O-ring of cover is clean. • Loose connections on the suction side. • Strainer basket or skimmer basket loaded with debris. • Suction side clogged. • Distance between pump inlet and liquid level is higher than 2m, height of pump installation should be lowered.
Low Water Flow.	<ul style="list-style-type: none"> • Pump does not prime. • Air entering suction piping. • Basket full of debris. • Inadequate water level in pool.
Pump being noisy	<ul style="list-style-type: none"> • Air leak in suction piping, cavitation caused by restricted or undersized suction line or leak at any joint, low water level in pool, and restricted discharge return lines. • Vibration caused by improper installation, etc. • Damaged motor bearing or impeller (need to contact the supplier for repair).

7.4 Error code

Item	Error Code	Description	Item	Error Code	Description
1	E001	Abnormal input voltage	10	E107	PFC protection
2	E002	Output over current	11	E108	Motor power overload
3	E003	No water Protection	12	E201	Circuit board error
4	E101	Heat sink over heat	13	E203	RTC time reading error
5	E102	Heat sink sensor error	14	E204	Display Board EEPROM reading failure
6	E103	Master driver board error	15	E205	Communication Error
7	E104	Phase-deficient protection	16	E209	Loss of prime
8	E105	AC current sampling circuit failure			
9	E106	DC abnormal voltage			

Note:

1. When E002/E101/E103 is displayed, the device will resume working automatically, however when it appears a fourth time, the device will stop working, to resume operation, unplug the device and plug in & restart again.

8. MAINTENANCE

Empty the strainer basket frequently. The basket should be inspected through the transparent lid and emptied when there is an evident stack of rubbish inside. The following instructions should be followed:

- 1). Disconnected the power supply.
- 2). Unscrew the strainer basket lid anti-clockwise and remove.
- 3). Lift up the strainer basket.
- 4). Empty the trapped refuse from the basket, rinse out the debris if necessary.

Note: Do not knock the plastic basket on a hard surface as it will cause damage

- 5). Inspect the basket for signs of damage, replace it.
- 6). Check the lid O-ring for stretching, tears, cracks or any other damage
- 7). Replace the lid, hand tightening is sufficient.

Note: Periodically inspect and clean the strainer basket will help prolong its life.

9. DISPOSAL

Observe all safety and warning information during installation and operation.

DISPOSAL CONSIDERATIONS

The transport and protective packaging has been selected from materials which are environmentally friendly for disposal, and can normally be recycled.

Recycling the packaging reduces the use of raw materials in the manufacturing process and also reduces the amount of waste in landfill sites. Ensure that any plastic wrappings, bags etc. are disposed of safely and kept out of the reach of babies and young children. Danger of suffocation.

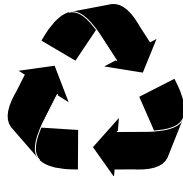

DISPOSING OF YOUR ELECTRICAL PRODUCT

Electrical devices marked with this label may not be disposed of in domestic waste at the end of their service life.

Electrical and electronic appliances often contain valuable materials. They also contain specific materials, compounds and components, which were essential for their correct function and safety. These could be hazardous to human health and to the environment if disposed of with your domestic waste or if handled incorrectly. Please do not, therefore, dispose of your old appliance with your household waste.

Please dispose of those materials by contacting your local authorities and ask for the correct method of disposal. Please ensure that your old appliance poses no risk to children while being stored prior to disposal.

By disposing of this product in accordance with the regulations, you protect the environment and the health of those around you from negative consequences.



10. DIAGRAM

10.1 Exploded view

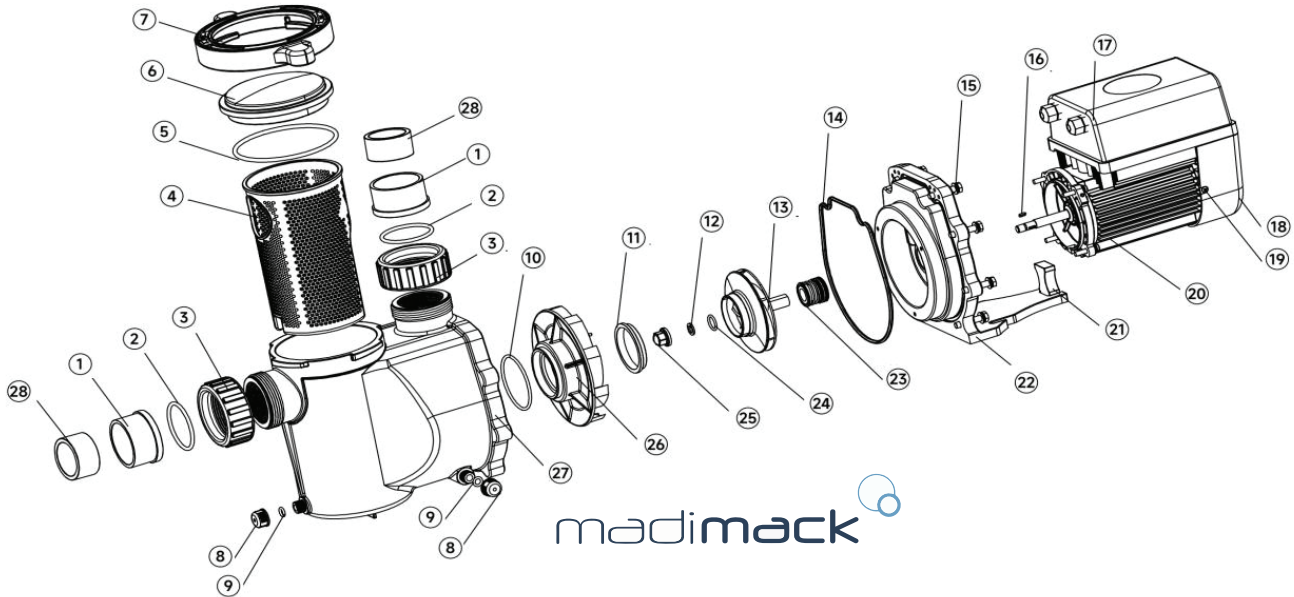

Explosive Diagram Code	Part Name	Quantity	Explosive Diagram Code	Part Name	Quantity
1	T union	2	16	Parallel key	1
2	O-ring (62×4.5mm)	2	17	Inverter controller	1
3	Union nut	2	18	Fan cover	1
4	Strainer basket	1	19	Cross recess head screw	3
5	O-ring (for Transparent Lid) (128×5.3mm)	1	20	Motor	1
6	Transparent Lid	1	21	Base	1
7	Nut for lid	1	22	Sealplate	1
8	Drain plug	2	23	Mechanical seal	1
9	O-ring (10×3mm)	2	24	O-ring (17×2.65mm)	1
10	O-ring (73×3.55mm)	1	25	Nut for impeller	1
11	Turnable ring	1	26	Diffuser	1
12	Spring washer	1	27	Pump body	1
13	Impeller	1	28	Reducing Bushing	2
14	Pump body gasket	1			
15	Stainless-Steel hex head bolt	8			

11. WARRANTY & EXCLUSIONS



STANDARD CONDITIONS - Australia and New Zealand

Madimack Pty Ltd distributes pool products and provides the following warranties:

STATUTORY RIGHTS

The benefits to the consumer under this warranty are in addition to other rights and remedies of the consumer under the laws in relation to the goods and services to which the warranty relates.

Our goods come with guarantees that cannot be excluded under Australian Consumer Law. You may be entitled to a replacement or refund for a major failure and compensation for any other loss or damage. You are also entitled to have the goods repaired if the goods fail to be of acceptable quality and the failure does not amount to a major failure.

LIMITED WARRANTY

Madimack warrants that its products are free from defects in materials and manufacture for a period of 3 years from the date of purchase, unless otherwise specified.

Please visit www.madimack.com.au for all warranty terms and conditions

Madimack will, at its discretion, repair or replace any product proven to be defective during the warranty period for either materials or manufacture. Alternatively, Madimack will pay the cost of repair or replacement within 90 days of receiving the defective product, subject to unforeseen delays. This warranty is applicable for domestic installations only, is personal to the original purchaser, and does not transfer to any subsequent purchasers.

EXCLUSIONS

To the extent permitted by law, Madimack excludes all statutory or implied conditions and warranties, as well as any other liability that may arise under statute or at law, including without limitation liability for breach of contract, negligence, or any other cause of action. The following exclusions apply:

- Incorrect installation or operation of the unit resulting from failure to follow the provided instructions.
- Damage caused to the due to misuse or any means other than a manufacturer defect.
- Repairs or servicing performed by unauthorized dealers or service stations.
- Damage caused by an unauthorized service station repairs.
- Faults in the machine's operation caused by the use of non-specified accessories.
- General wear and tear of consumable items.

LIMITATION OF LIABILITY

To the extent permitted by law, Madimack's liability under any condition or warranty that cannot be legally excluded in relation to the supply of goods and services is limited to one of the following options:

- Repairing the goods.
- Replacing the goods with equivalent products or services.
- Paying the cost of replacing the goods or providing equivalent products or services again.
- Paying the costs of repairing the goods.

PROCEDURE FOR WARRANTY CLAIMS

Making a claim

The following steps should be taken when making a warranty claim with Madimack Pty Ltd.

- 1) Owners experiencing issues with their system are to contact Madimack Pty Ltd service departments online portal to and provide the requested information. www.madimack.com.au
- 2) A service agent will review the provided information and will contact you on the provided phone number to try and solve the issue.
- 3) If the issue cannot be dealt with over the phone, owners will be supplied with details of service agent in their area
- 4) Owners will need to contact and deal with service agents directly in relation to the booking in and payments of works related to the service or repair of their Madimack Pool Heat Pump.
- 5) Owners can claim reimbursement for costs of works covered under the product warranty when completed by an approved Madimack Service Agent. When making a claim, owners will need to provide the following documents.
 - Proof that you are the original system owner – original invoice showing owner name and property address.
 - Copy of invoice from an approved Madimack approved service agent.
 - For a major defect a copy of the report for major defects from approved Madimack Service agent.

In the event of a warranty claim, the faulty product should be returned to the place of purchase or, to an authorised service and warranty agent repair centre.

You are responsible for arranging the removal of the defective product and the installation of the repaired or replacement product. This includes all transportation costs and any applicable insurance fees associated with transporting the products to the supplier and the replaced or repaired product from the supplier.

All returns require Madimack's written approval and must be accompanied by either:

A service support ticket authorized by Customer Service Manager or Authorised Agent, or A "Return Goods Authorisation"

