

# PP60 pH

PERISTALTIC PUMP FOR pH REGULATION





## General safety information

This user manual contains basic information that should be observed during assembly, start-up, operation, and maintenance. Therefore, this user manual must be read by installers and operators prior to assembly and start-up, and must be accessible to every user of this unit. Additionally, all further safety information in this document absolutely must be observed. Read and follow all instructions. In order to minimize the danger of injury, do not allow children to use this product. Hazards from non-compliance with safety information. Non-compliance with safety information can result in hazards to persons, the environment, and the equipment. Non-compliance with safety information will result in a forfeit of any potential right to damage compensation.

### Insufficient personnel qualification

Hazards in the event of insufficiently qualified personnel, potential consequence: Injury, heavy material damage.

- The system operator must ensure compliance with the required qualification level.
- Any and all work may only be performed by correspondingly qualified personnel.
- Access to the system must be prevented for insufficiently qualified persons, e.g. via access codes and passwords.

### Potential overdosing of chemical agents

Despite PP60 pH® comprehensive safety functions, it is possible that a probe failure and other errors could lead to an overdosing of chemical agents. Potential consequence: Injury, heavy material damage.

- Design your installation such that uncontrolled dosage is not possible in the event of a probe failure or other errors, and/or such that uncontrolled dosage is recognized and halted before damage is incurred.
- Uncontrolled overdose of chemicals can cause harm to health and property. Even though the device contains a number of security elements can not be ruled out that in case of failure of the measuring probes, or the whole device may result in overdose of chemical agents. Install the equipment so that uncontrolled overdose of chemicals was not possible and that uncontrolled overdose has been detected in time before causing any harm. It is necessary to use chemicals in such quantities that an overdose will not cause dangerous concentration of chemical agents. Do not use chemicals in too large packages or with too high concentration.

### Gaseous chlorine produced from dosing in standing water if dosing outputs are not closed via the filter pump

If the flow switch is stuck or experiences another error, there is a risk of dosing into standing water. Poisonous chlorine gas can be yielded when sodium hypochlorite and pH minus come together.

### Non compliance with informational text

There is a great deal of informational text indicating hazards and their avoidance. Not observing informational text may lead to hazards. Potential consequence: gravest degree of injury, heavy material damage.

- Read all informational text carefully.
- Cancel the process if you are unable to exclude all potential hazards.

## Use of new functions

Because of the continued development, a PP60 pH® unit may contain functions, which are not completely described in this version of the user manual. The use of such new or extended functions without a profound and secure understanding by the operator may result in malfunctions and severe problems. Potential consequence: Injury, heavy material damage.

- Make sure to get a profound and secure understanding of a function and relevant boundary conditions, before you start to use it.
- Check for an updated version of the user manual or additional documentation available for the relevant functions.
- Make use of the integrated help function of the PP60 pH® to get detailed information on functions and their parameter settings.
- In case it should not be possible to get a profound and secure understanding of a function based on the available documentation, do not use this function.

## Overdosing if pH value is wrong

If disinfection is enabled before the pH value is stable in the ideal range of 7.0 to 7.4, then it may lead to heavy overdosing of chlorine or bromine. Potential consequence: Injury, heavy material damage.

- Do not start disinfection with chlorine until the pH value is stable in the ideal range between 7.0 and 7.4.

## Conditions before using

Make sure you have a newest and updated version of the user manual and other documentation for all functions of the unit. Use and read the integrated help features. In case of not understanding the information about certain features of the unit, do not use these features.

## Handling chemicals for pool water treatment

The chemicals used with the PP60 pH must be handled in a safe manner to prevent damage or personal harm. Aseko recommends you always use personal protective safety equipment when handling the pH and chlorine agents. Refer to the Materials Safety Data Sheet (MSDS).

**WARNING:** Never mix the pH agent with the chlorine agent. When carrying out maintenance on the clear plastic tubes or valves always rinse with clean water to prevent mixing of the pH and chlorine agents.



# What's in the box

PP60 pH #13260

Peristaltic pump  
#12117



pH probe Long Life  
#12012

pH probe Long Life  
#12012

Injection valve  
#12005

Suction tube weight  
#12023



Probe wrench  
#13046

Measuring Water Valve 2 pcs  
#12006

Dowels and screws

PE Tube 1/4" (6.35 mm) transparent  
#12008



# Accessories

Vleповací zátka se závitem 1/4"  
#12134



pH - Buffer 7,00  
#12065



Fotometr  
# 13076



# Original aseko chemicals



pH MINUS 20l  
#12130



pH MINUS 5l  
#12131



pH PLUS 20l  
#12120



pH PLUS 5l  
#12136

# Peristaltic pump PP60 pH

PP60 pH automatically regulates the pH value of the pool water, measured by a standard pH probe. The set pH value is shown on the red LED display. LED display also serves to set all the necessary parameters. During operation, the required dose of the reagent is calculated from the measured value and the dose is then disposed into the pool water. The PP60 pH is composed of a control unit, a measuring probe, and a dosing pump with a maximum pump power of 60 ml / min.

## Technical information

### WARNING

PP60 pH power supply must be connected together with the power supply of the circulation pump. Switching off the circulation pump must switch off the PP60 pH, otherwise inaccurate measurement and incorrect dosing would occur.

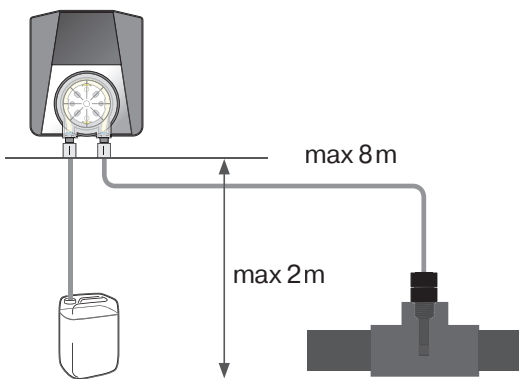
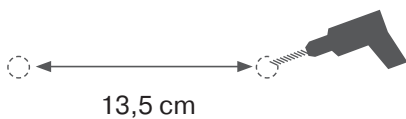
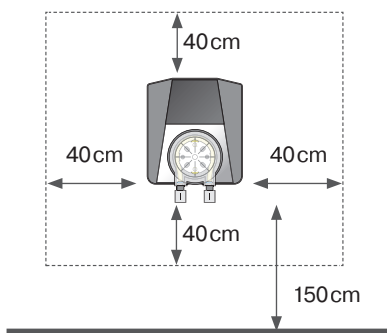
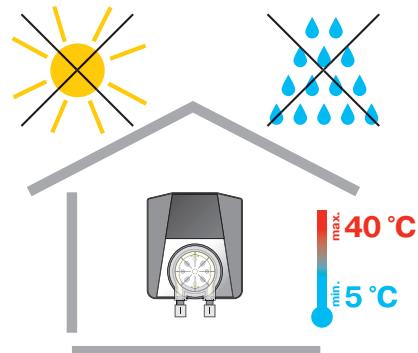

Power supply	230 V / 50 Hz
Power consumption	20 VA
Fuse	T80 mA
Overvoltage category	II
Protection	IP30
Operating temperature	+5 to +40°C
Weight	2268g
Installation	Wall mounted
Pump power	60 ml / min
Max water pressure	1 bar

## Installation PP60 pH

PP60 pH is to be wall mounted in dry and dust-free environment with temperature ranging from +5 °C to +40 °C. To mount the device, use the mounting holes that are accessible after opening the front cover of the device. To mount the device use screws supplied with the device.

**WARNING:** The location temperature should permanently be in the range from +5 °C to +40 °C.

Direct sunlight, high humidity and dust may lead to damage to PP60 pH.

- Before installing, ensure that pool water is chemically clean and free of dirt.
- The maximum distance of injection valves from peristaltic pump of PP60 pH must not be greater than 8 m.
- Vertical distance between PP60 pH and the bottom of containers must not exceed 2 m.

# Probe installation

1. Carefully insert the pH probe into the housing.
2. Hand tighten or use the attached plastic wrench socket for probes.
3. Connect the connector and lock it by tightening a connector ring.

After probes have been inserted, slightly tightened and connectors have been connected, PP60 pH is ready for connection to the water system of your pool.

**WARNING:** Only hand tighten the probes or use the attached plastic wrench socket for probes. Do not use pliers or steel wrench.

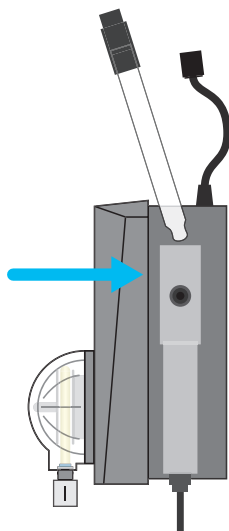

Housing for  
pH probe  
#13013

pH probe Long Life  
#12012



Probe wrench  
#13046

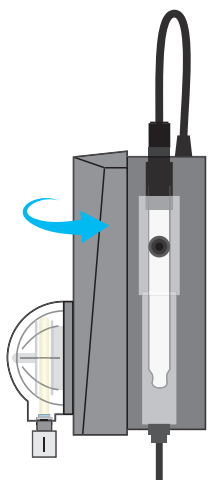

# Pool Water Connection

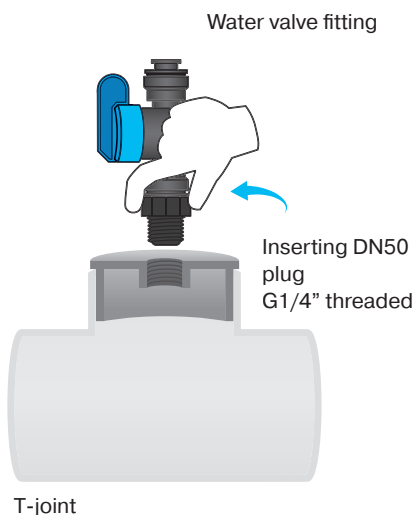
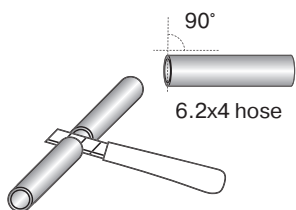
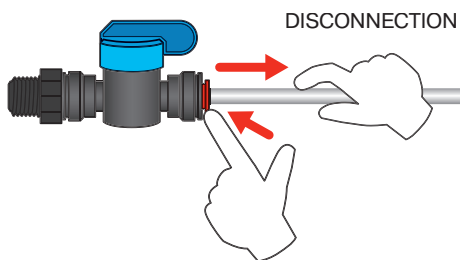
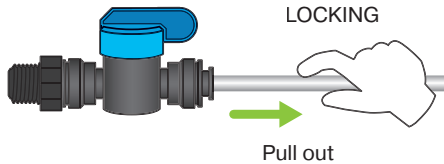
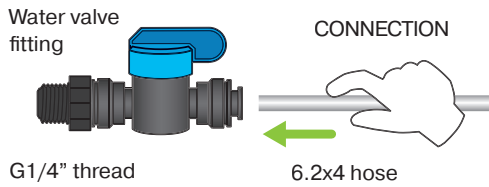

The pool water to be measured must be connected to PP60 pH. Connect the measured water inlet downstream of the pump, upstream of the filter and ZPM (coagulation mixer).

Place the water valve fitting to the T-joint, blinded by DN50 G1/4" threaded plug #12134.

- The connecting fitting is installed in G1/4" thread.

Aseko provides the unique Speedfit connecting fitting for measured water connection to your PP60 pH. To connect the interconnecting tube, push it into the Speedfit connector and then lock it by pulling back. To disconnect the interconnecting tube, push and hold a circular collet and pull the interconnecting tube out.

**WARNING:** To treat PE tube ends, use a sharp knife (part of delivery). The use of scissors or tongs deforms the tube end and leads to leaks.

**WARNING:** Only hand tighten. Do not use tongs or any other tools.

1. To ensure tightness of joints, cut the tube at 90 ° angle.
  - Use the sharp knife to cut plastic. The cut must be clean and smooth.
2. Connect the water inlet to the measured water filter connection and the water outlet to the probe housing connection. Make sure that measured water pressure does not exceed 1.5 bar.
3. The water outlet can be realized:
  1. downstream of filtration
  2. to non-pressure (overflow tank)
  3. upstream of filter pump

After the water inlet has been connected and opened, your PP60 pH is ready to measure and adjust the pH and Cl value in your pool so as to achieve the required values.



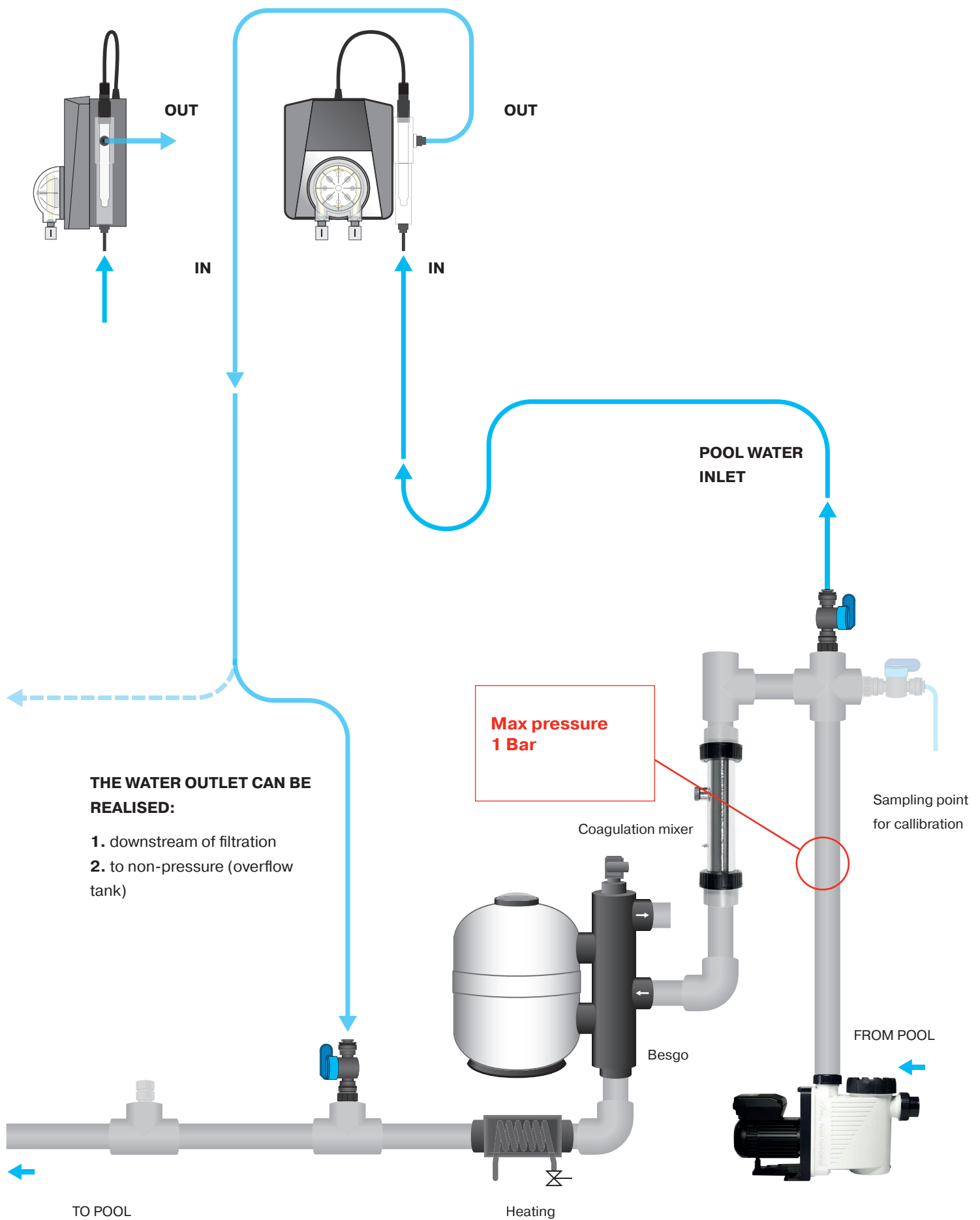

**THE WATER OUTLET CAN BE REALISED:**

- 1. downstream of filtration
- 2. to non-pressure (overflow tank)

# Pool Chemicals Connection

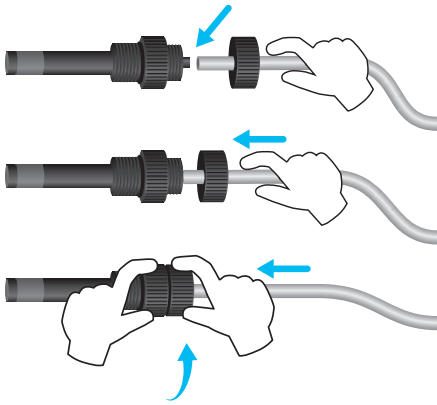

At this step is necessary to connect the injecting valves of individual chemicals to the dosing pumps and dosed agents.

Place the injecting valve in the T-joint, blinded with the DN50 G1/4" threaded plug #12134.

1. Cut the PE tube at 90 ° angle to ensure proper fitting.
  - Use the sharp knife to cut plastic. The cut must be clean and smooth.
2. Drill the 6 mm hole and the 1 mm hole (air suction) into the CHLORPURE canister cap. Push the PE tube through the cap. Select the tube distance so that the tube reaches the canister bottom and can be connected to the pump as straight as possible. A long tube in the canister would bend and produce air bubbles.
3. Put a weight on the tube end and dive it in the canister.
4. Connect the plastic tube from the pH canister to the pump to the left connection.
5. Connect the plastic tube to the pump right connection and the injection valve.
6. Hand screw the injection valve in the specified mounting hole (see diagram).
  - The injection valve is installed in G 1/4" thread.
  - Check throughput of the injection valves and tightness of the entire system.

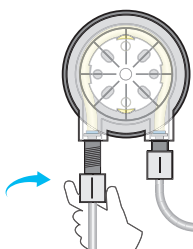
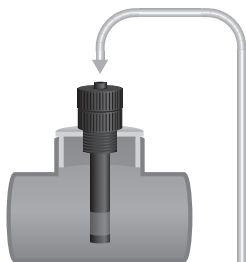
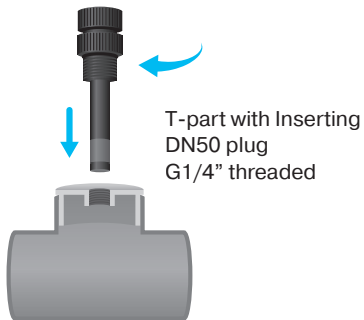

Ø 6,35 mm

Ø 1 mm

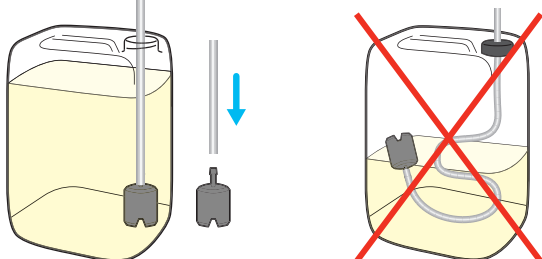

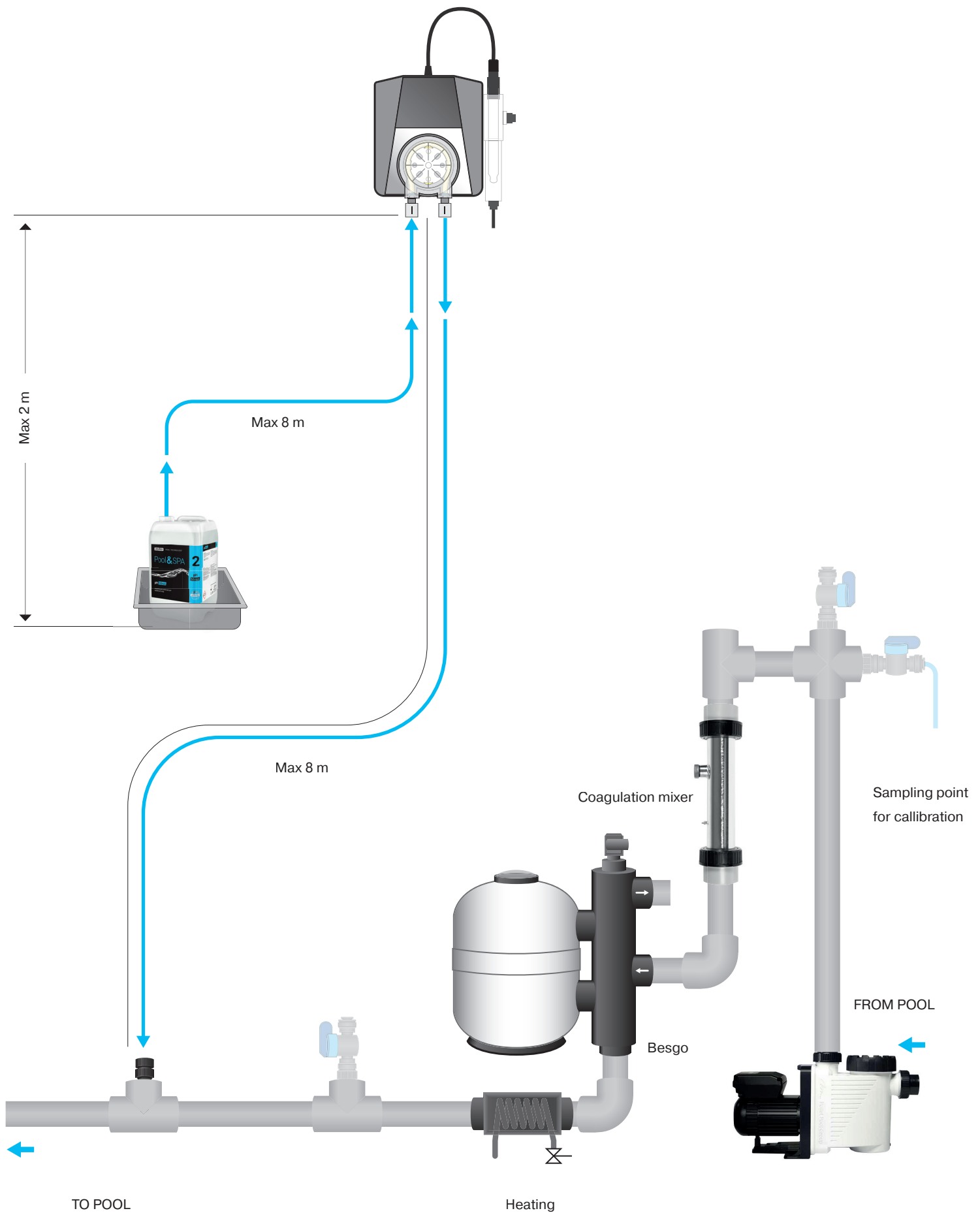

# Initial start

## Power connection

PP60 pH is switched on by connecting to the power supply. PP60 pH power supply must be connected together with the power supply of the circulation pump. Switching off the circulation pump must switch off the PP60 pH, otherwise inaccurate measurement and incorrect dosing would occur. PP60 pH is to be installed in the pool with clean water without any pool chemicals. When the device is switched on by connecting to the mains, the actual measured pH value lights up on the display.

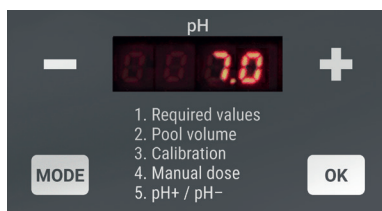

## Initial start setup

Below the display is a list of menu items. To move in the list use the MODE button. The values displayed are adjusted with the + and - buttons. The set value must be confirmed with the OK button. Then return to the operating mode by pressing the MODE button repeatedly.

To set up the device for the first time, follow the procedure below:

1. In the control menu, select **2. Pool volume**. Enter the volume of your pool in m<sup>3</sup>.
2. In this step, we advise testing the connections tightness. In the control menu, select **4. Manual dose**. The display shows the dose in ml. Press the **OK** button to start manual dosing and monitor the process of the dosing liquid in the transparent tubes up to the inlet to the circulation pipe. When the liquid reaches the circulation pump, end the manual dosing by pressing **OK**. Check whether the liquid in the tube is not falling back. If the liquid is falling back check the leakage of PE Tube.
3. Select **1. Required values**, set the desired pH value to which you want to regulate
4. Select **5. pH+ / pH-** set which reagent you want to dose into the pool.
5. After starting the circulation pump, check that the water flows to the pH probe.
6. In operation, there may be a difference between the measured and the actual pH value in the water. Calibration can be performed in two ways:
  - Remove the probe from the device. The probe must remain connected to the device with a cable. Rinse the probe with clean water and wipe. Dip it in calibration buffer 7.0. After stabilizing the value, enter the value in **3. Calibration**, which will perform the calibration.
  - Measure the pH value directly in the pool water using a photometer. Enter the manually measured value in **3. Calibration**.
7. Press the **MODE** button repeatedly to return to operating mode.

# Error messages

## Agent Run Out

- Check liquid levels on a regular basis, refill in time.

## Dosing Pump does not Dose

- Leakage in connection of PE tubes or they are damaged.
- Failure of dosing pump. Check whether pump is running. If so, check the hose inside the pump for damage or breakage and replace it, if required.

## Injection Valve Clogged

- Impassable injection valve.  
Check the valve for being clogged with impurities or deposits or the rubber seal for being damaged.
- Failure of dosing pump. Check whether pump is running.  
If so, check the hose inside the pump for damage or breakage and replace it, if required.

## No Water Flow to Probe

- Check the measured water filter and clean it, if required.
- Check condition of connecting tubes from the extraction valve to the measured water inlet to probes and furthermore, from the water outlet from probes to the closing valve.
- Check condition of the extraction valve and the closing valve and their seals, for being clogged and their closed position.

## Probe out of Service

- Measure pH using the hand tester. If the pH value is too low, a respective agent was overdosed due to an incorrect probe function (provided that other reasons given in the previous points have been excluded).
- Take the probe out and check it for mechanical damage.
- Clean the probe following the above procedure.
- It is recommended to replace the probes with the new probes every two years.

## Fuse failed

If the input voltage to the peristaltic pump is OK and the pump does not work, the mains fuse may have failed. The fuse is located on the PCB inside of the device. To replace the fuse follow the procedure below:

1. unplug the power cord
2. unscrew and remove the front cover of the pump
3. replace fuse
4. restore the device to its original state

# PP60 pH maintenance

To ensure the optimum efficiency, perform visual checks and maintenance of PP60 pH on a regular basis.

#12073 Replacement tube kit for PP 60

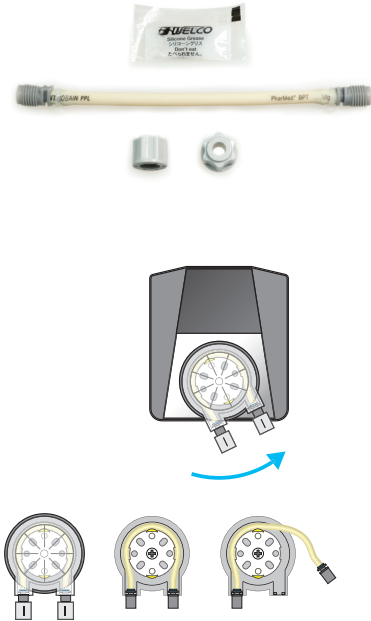

## Pump Hose Replacement

To prevent the pump from failing, it is recommended to replace the hose #12073 every 24 months.

**In doing so, proceed as follows:**

- Switch off PP60 pH.
- Turn the pump cover cassette counterclockwise and take it out of PP60 pH.
- Release both hose ends and take it out of the cassette.
- Lubricate the new hose with the supplied special grease.
- Insert the lubricated hose into the cassette.
- Place the cover cassette back on PP60 pH and turn it clockwise to lock it.
- Use new nuts, which are part of the replacement hose set, for connection of the PE tube.

## Injection Valve Maintenance

#12005 Injection valve



On a regular basis, check throughput of the injection valves, rubber band integrity, remove scale.

In case of private pools, replace injection valve rubber bands every 2 years.

In case of public pools, replace injection valve rubber bands every year.

#13087 Injection valve rubber







USER'S MANUAL

# PP60 pH

