

PP10 Flocc

PROGRAMMABLE PERISTALTIC PUMP
FOR SLOW CONTINUOUS DOSING





General safety information

This user manual contains basic information that should be observed during assembly, start-up, operation, and maintenance. Therefore, this user manual must be read by installers and operators prior to assembly and start-up, and must be accessible to every user of this unit. Additionally, all further safety information in this document absolutely must be observed. Read and follow all instructions. In order to minimize the danger of injury, do not allow children to use this product. Hazards from non-compliance with safety information. Non-compliance with safety information can result in hazards to persons, the environment, and the equipment. Non-compliance with safety information will result in a forfeit of any potential right to damage compensation.

Insufficient personnel qualification

Hazards in the event of insufficiently qualified personnel, potential consequence: Injury, heavy material damage.

- The system operator must ensure compliance with the required qualification level.
- Any and all work may only be performed by correspondingly qualified personnel.
- Access to the system must be prevented for insufficiently qualified persons, e.g. via access codes and passwords.

Potential overdosing of chemical agents

Despite PP10 comprehensive safety functions, it is possible that a probe failure and other errors could lead to an overdosing of chemical agents. Potential consequence: Injury, heavy material damage.

- Design your installation such that uncontrolled dosage is not possible in the event of a probe failure or other errors, and/or such that uncontrolled dosage is recognized and halted before damage is incurred.
- Uncontrolled overdose of chemicals can cause harm to health and property. Even though the device contains a number of security elements can not be ruled out that in case of failure of the measuring probes, or the whole device may result in overdose of chemical agents. Install the equipment so that uncontrolled overdose of chemicals was not possible and that uncontrolled overdose has been detected in time before causing any harm. It is necessary to use chemicals in such quantities that an overdose will not cause dangerous concentration of chemical agents. Do not use chemicals in too large packages or with too high concentration.

Gaseous chlorine produced from dosing in standing water if dosing outputs are not closed via the filter pump

If the flow switch is stuck or experiences another error, there is a risk of dosing into standing water. Poisonous chlorine gas can be yielded when sodium hypochlorite and pH minus come together.

Non compliance with informational text

There is a great deal of informational text indicating hazards and their avoidance. Not observing informational text may lead to hazards. Potential consequence: gravest degree of injury, heavy material damage.

- Read all informational text carefully.
- Cancel the process if you are unable to exclude all potential hazards.

Use of new functions

Because of the continued development, a PP10 unit may contain functions, which are not completely described in this version of the user manual. The use of such new or extended functions without a profound and secure understanding by the operator may result in malfunctions and severe problems. Potential consequence: Injury, heavy material damage.

- Make sure to get a profound and secure understanding of a function and relevant boundary conditions, before you start to use it.
- Check for an updated version of the user manual or additional documentation available for the relevant functions.
- Make use of the integrated help function of the PP60 to get detailed information on functions and their parameter settings.
- In case it should not be possible to get a profound and secure understanding of a function based on the available documentation, do not use this function.

Overdosing if pH value is wrong

If disinfection is enabled before the pH value is stable in the ideal range of 7.0 to 7.4, then it may lead to heavy overdosing of chlorine or bromine. Potential consequence: Injury, heavy material damage.

- Do not start disinfection with chlorine until the pH value is stable in the ideal range between 7.0 and 7.4.

Conditions before using

Make sure you have a newest and updated version of the user manual and other documentation for all functions of the unit. Use and read the integrated help features. In case of not understanding the information about certain features of the unit, do not use these features.

Handling chemicals for pool water treatment

The chemicals used with the PP10 must be handled in a safe manner to prevent damage or personal harm. Aseko recommends you always use personal protective safety equipment when handling the pH and chlorine agents. Refer to the Materials Safety Data Sheet (MSDS).

WARNING: Never mix the pH agent with the chlorine agent. When carrying out maintenance on the clear plastic tubes or valves always rinse with clean water to prevent mixing of the pH and chlorine agents.



What's in the box

PP10 Flocc #13260



Peristaltic pump #12117

Injection valve
#12005



Suction tube weight
#12023



Dowels and screws



PE Tube 1/4" (6.35 mm)
transparent
#12008



Optional accessories

Inserting DN50 plug 1/4" threaded
#12134



Coagulation mixer
30001



ASEKO Pool Tester
#12170



ASEKO original chemicals



FLOC+C 20I
#12139



FLOC+C 5I
#12138

PP10 Flocc

Effective coagulation and flocculation happens only with continuous dosing. The peristaltic pump PP10 Flocc is designed to dose FLOC+C but also other flocculants and coagulants. Especially for treatment of the swimming pool water and hot tubs. The pump enables to preset the dosing volume per hour.

The PP10 Flocc is equipped with touchscreen which allows easy setup of the system and the required dose of Flocc.

Technical description

Power supply	230 V / 50 Hz
Power consumption	4,5 VA
Fuse	T500 mA
Over-voltage category	II
Ingress protection	IP50
Operating temperature	+5 to +40 °C
Weight	530 g
Installation	wall mounted
Pump output	10 ml / min / max. 1 bar
Max. water pressure	1 bar
Dimensions	125 x 140 x 120 mm

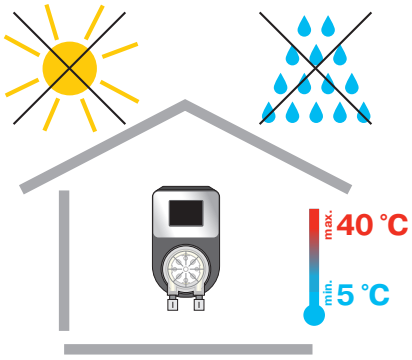

PP10 Flocc Installation

PP10 Flocc should be wall mounted in dry and dust-free environment with temperature ranging from +5 °C to +40 °C. For mounting, use holes that are accessible after opening the front cover of the PP10 Flocc. Select location so that free space at least 40 cm in all directions and height above floor at most 150 cm are provided.

WARNING: The location temperature should permanently be in the range from +5 °C to +40 °C.

Direct sunlight, high humidity and dust may lead to damage to PP10 Flocc.

- Before installing, ensure that pool water is chemically clean and free of dirt.
- The maximum distance of injection valves from peristaltic pump of PP10 Flocc must not be greater than 8 m.
- Vertical distance between PP10 Flocc and the bottom of containers must not exceed 2 m.

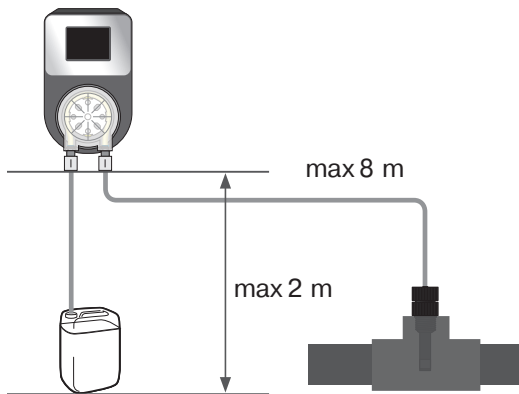
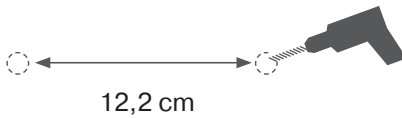
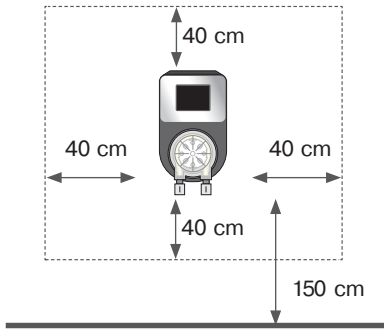

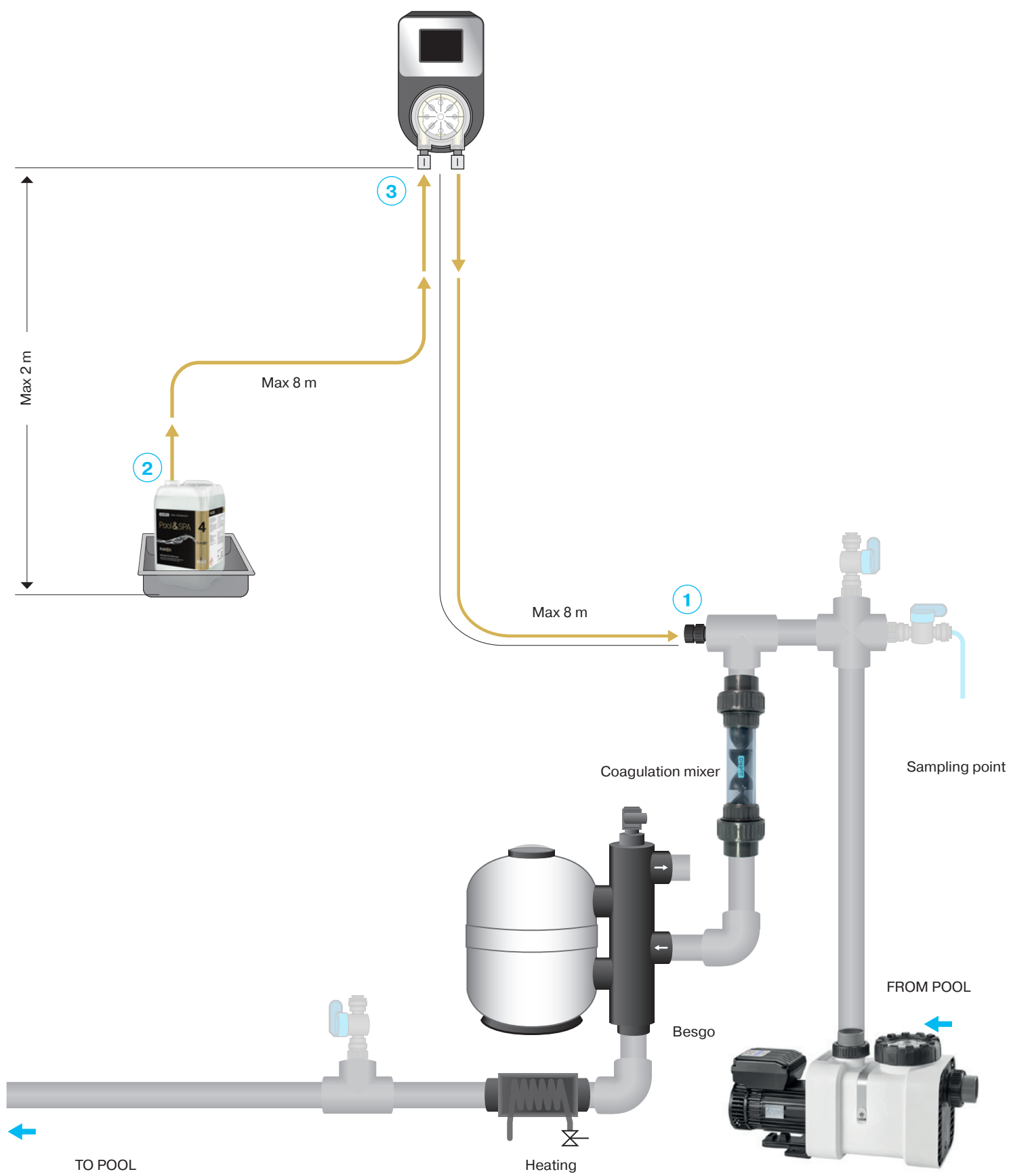

Pool Chemicals Connection

Screw the **injection valve** in the glue head D50 with thread G1 / 4 " #12134, glued to the T-piece. **Tighten the injection valve into the head by hands only. Do not use pliers or other tools.**

- 1 Connect the **FLOC+C INJECTION VALVE** to the pipe **before the coagulation mixer and before the filter.**

To connect reagents from cans to the PP10 Flocc and from the PP10 Flocc to the injection valves use PE Tube 1/4 "(6.35 mm) #12008, which is part of the packaging.

WARNING

Cut the PE tube at an angle of 90° to ensure tight joints. The cut must be clean. Use special pliers #13325 to cut plastic tubes. Do not use common scissors or knives!

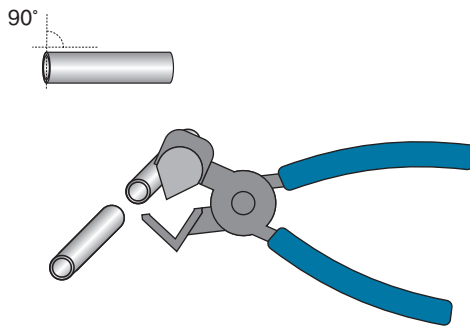

- 2 **CANISTER CONNECTION** Drill 6.35 mm and 1 mm diameter holes in the can's cap. Pass the tube through the hole in the cap so that it reaches the bottom of the can. Place the suction tube weight at the end of the tube.
- 3 **PUMP CONNECTION** Connect the can with the left (suction) connector of the pump using a PE tube from the can.
- 4 **INJECTION VALVE CONNECTION** Pass the tube through the injection valve nut, connect the tube onto the injection valve and tighten the nut firmly by hand. Connect the tube from injection valve with the right (discharge) connector of the pump.

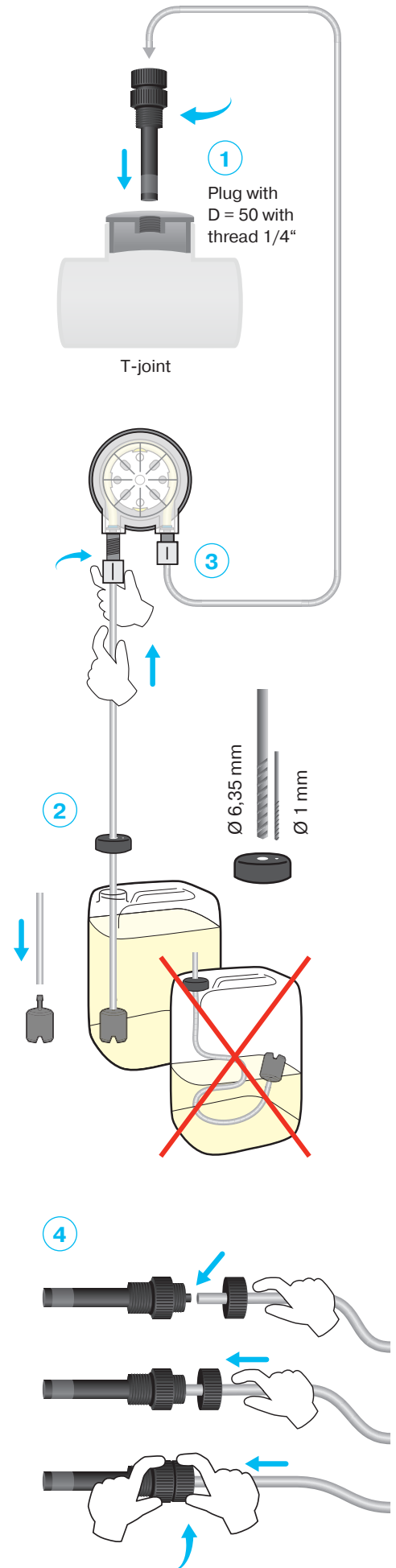

Orientation in the menu

When the mains cable is plugged in, the touch display of the device lights up.

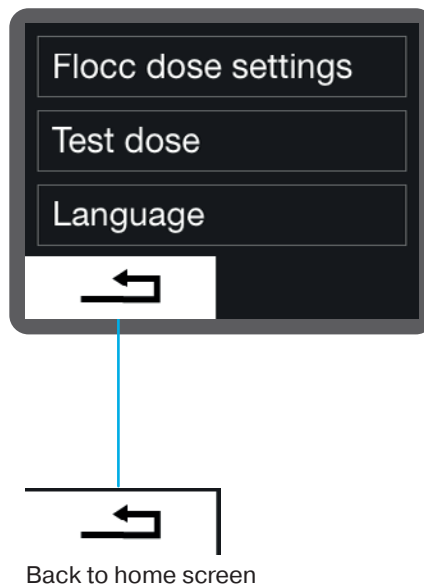
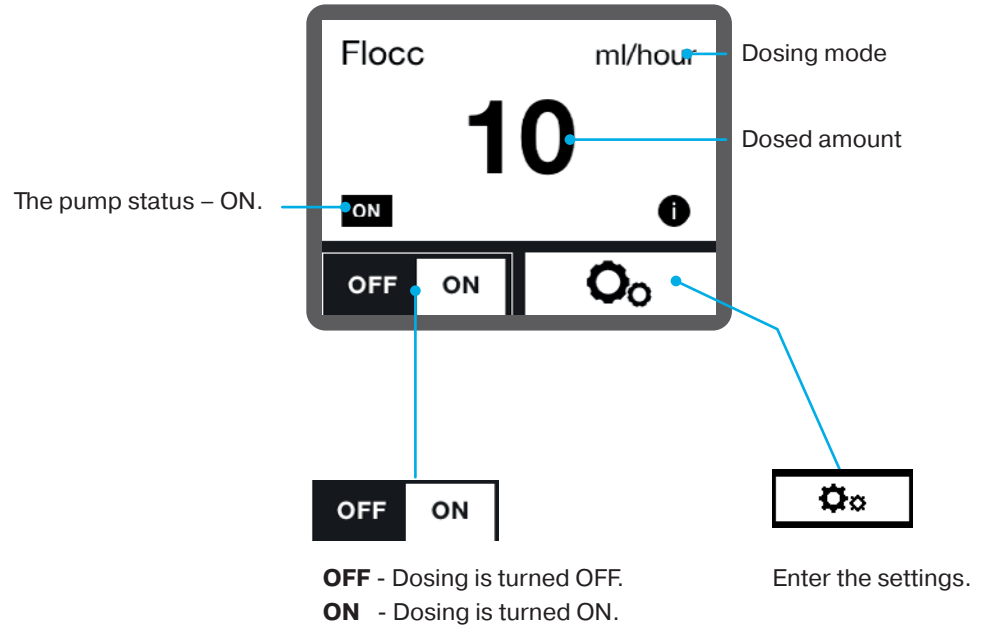

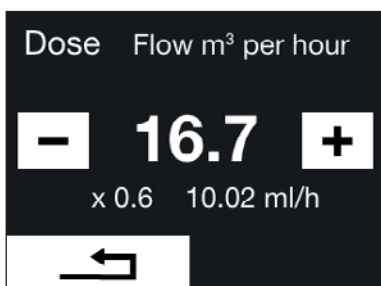
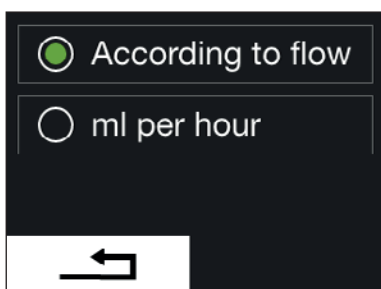
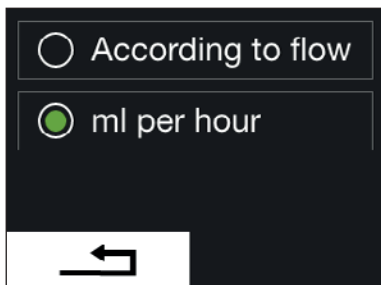
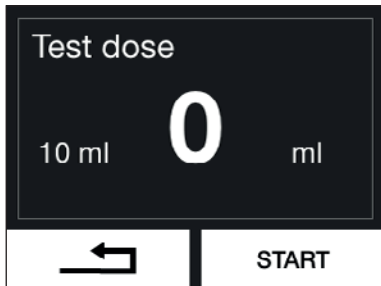
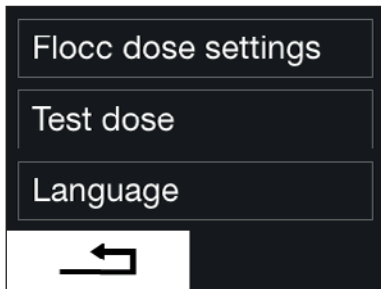

Initial setup

PP10 is switched on by connecting to the power supply. PP10 power supply must be connected together with the power supply of the circulation pump. Switching off the circulation pump must switch off the PP10, otherwise incorrect dosing would occur.

1. Turn on the unit
2. Select preferred language. Enter the settings and in the language menu select one of available languages.
3. Test the connections tightness. In the settings, select **Test dose**. The display shows the dose in ml. Press the **START** button to start manual dosing and monitor the liquid in the transparent tubes up to the inlet to the pipe. When the liquid reaches the pipe, stop the manual dose by pressing **STOP**. Check whether the liquid in the tube is not falling back. If the liquid is falling back look for leakage of the PE Tube.
RECOMMENDATION: During the initial connection tightness test, replace the chemical canister with containers of water to avoid chemical spillage.
4. Set preferred Floc dosing method. In the Floc dose settings chose one of the FLOC+C dosing methods.
 - ml per hour - the optimal dose of FLOC+C in ml/h is calculated from the amount of water flow in your system. E.g. with the amount of water flow in your system of 10m³/h enter 10 ml/h.
 - According to flow - enter the power on the label of the circulation pump. E.g. with the circulation pump with power of 10 m³/h set 10. The system will calculate the optimal dose.

Errors

Agent run out

- Check liquid levels on a regular basis, refill in time.

Dosing pump does not dose

- Leakage in connection of PE tubes or they are damaged.
- Failure of dosing pump. Check whether pump is running. If so, check the hose inside the pump for damage or breakage and replace it, if required.

Injection valve clogged

- Impassable injection valve.
Check the valve for being clogged with impurities or deposits or the rubber seal for being damaged.
- Failure of dosing pump. Check whether pump is running.
If so, check the hose inside the pump for damage or breakage and replace it, if required.

PP10 maintenance

To ensure the optimum efficiency, perform visual checks and maintenance of PP10 on a regular basis.

Pump hose replacement

To prevent the pump from failing, it is recommended to replace the hose #12073 every 24 months.

In doing so, proceed as follows:

- Switch off PP10.
- Turn the pump cover cassette counterclockwise and take it out of PP10.
- Release both hose ends and take it out of the cassette.
- Lubricate the new hose with the supplied special grease.
- Insert the lubricated hose into the cassette.
- Place the cover cassette back on PP10 and turn it clockwise to lock it.
- Use new nuts, which are part of the replacement hose set, for connection of the PE tube.

#12073 Replacement tube kit for PP 60



#12005 Injection valve



Injection valve maintenance

On a regular basis, check throughput of the injection valves, rubber band integrity, remove scale and impurities.

In case of private pools, replace injection valve rubber bands every 2 years. In case of public pools, replace injection valve rubber bands every year.

#13087 Injection valve replacement flap



Fuse T 80 mA #13095



Fuse replacement

If the input voltage to the peristaltic pump is OK and the pump does not work, the mains fuse may have failed. The fuse is located on the PCB inside of the device. To replace the fuse follow the procedure below:

1. unplug the power cord
2. unscrew and remove the front cover of the device
3. replace fuse T 80 mA with a new one.
4. restore the device to its original state

Winterizing - storage during winter

The device and all accessories must be dismantled, winterized and moved to a suitable location. To disassemble and winterize the PP10 Flocc, follow the instructions below.

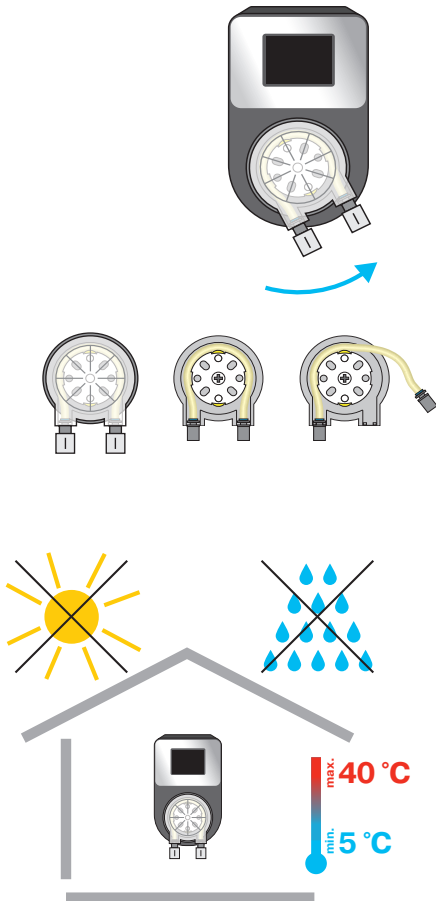

Storing of pool chemicals, connecting PE tube and dosing pumps

- If the chemicals are left in a place where the temperature does not drop below 0°C, turn OFF the PP10 Flocc. Disconnect the dosing pumps from the PP10 Flocc and remove the inner tube from the pump. Leave the tube connected to the connecting PE tube. Put the pump cartridges without the inner tubes back onto the PP10 Flocc. Store the chemical barrels and connecting PE tube in a place where the temperature is between +0 - +40 °C.
- If chemicals remain in a location where the temperature drops below 0°C, SWITCH OFF PP10 Flocc. Remove the connecting PE tubes from the chemical barrels and place them in a container with water. Turn on PP10 Flocc. Go to the TEST DOSE menu and START the dosing manually. When the connecting PE tube is completely filled with water, turn OFF the relay test. Remove the water container and perform the TEST DOSE again to completely fill the connecting PE tube with air. When the connecting PE tube is completely filled with air, stop the TEST DOSE and turn OFF the PP10 Flocc. Disconnect the connecting PE tubes from the dosing pumps and from the injection valves. Store the chemical barrels in a place where the temperature is between +0 - +40 °C.

Storage of the PP10 Flocc

Disconnect the PP10 Flocc mains cable from the 230 V / 50 Hz socket. Move the PP10 Flocc unit in a place where the temperature is between +5 - +40 °C and the humidity does not exceed 70%.

Enhancement of filtering efficiency



AFM® activated filter media

AFM is direct substitute for filter sand. It doubles efficiency of the existing filtration system. AFM® is resistant to biological pollution and formation of so-called bio-film.



ZPM® coagulation mixer

ZPM increases effects of coagulation and flocculation for transition of smaller dissolved solids (turbidity) to larger particles that can be removed by filtering.

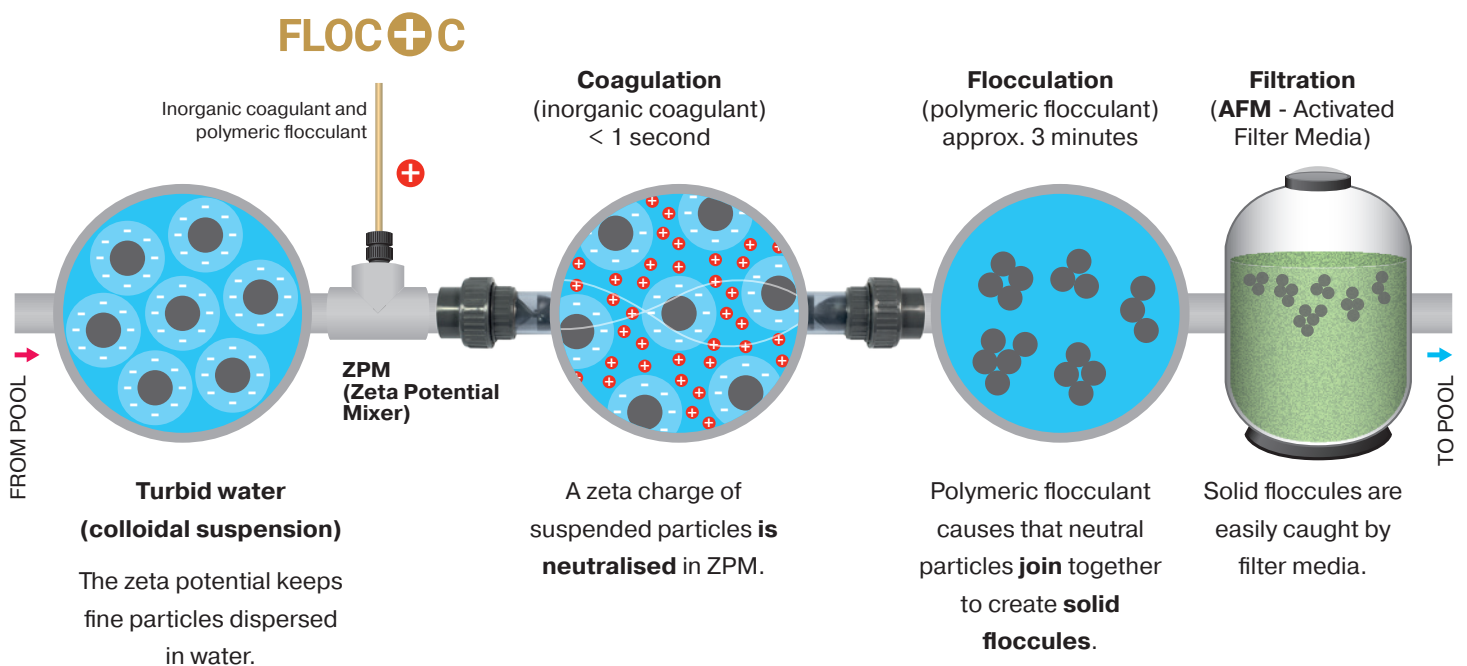



USER'S MANUAL

PP10

